

# Ultra

## Ultra User Manual

v7.1

---

## Thank You For Choosing Ross

You've made a great choice. We expect you will be very happy with your purchase of Ross Technology.

Our mission is to:

1. Provide a Superior Customer Experience
  - offer the best product quality and support
2. Make Cool Practical Technology
  - develop great products that customers love

Ross has become well known for the Ross Video Code of Ethics. It guides our interactions and empowers our employees. I hope you enjoy reading it below.

If anything at all with your Ross experience does not live up to your expectations be sure to reach out to us at [solutions@rossvideo.com](mailto:solutions@rossvideo.com).

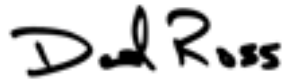

David Ross  
CEO, Ross Video  
[dross@rossvideo.com](mailto:dross@rossvideo.com)

## Ross Video Code of Ethics

Any company is the sum total of the people that make things happen. At Ross, our employees are a special group. Our employees truly care about doing a great job and delivering a high quality customer experience every day. This code of ethics hangs on the wall of all Ross Video locations to guide our behavior:

1. We will always act in our customers' best interest.
2. We will do our best to understand our customers' requirements.
3. We will not ship crap.
4. We will be great to work with.
5. We will do something extra for our customers, as an apology, when something big goes wrong and it's our fault.
6. We will keep our promises.
7. We will treat the competition with respect.

8. We will cooperate with and help other friendly companies.
9. We will go above and beyond in times of crisis. *If there's no one to authorize the required action in times of company or customer crisis - do what you know in your heart is right. (You may rent helicopters if necessary.)*

## Document Information

- Ross Part Number: **4841DR-110-07.1**
- Release Date: March, 2023.
- Equipment: This document applies to the Ultra switcher.

## Copyright

©2023 Ross Video Limited, Ross®, MiniME™, and any related marks are trademarks or registered trademarks of Ross Video Limited. All other trademarks are the property of their respective companies. PATENTS ISSUED and PENDING. All rights reserved. No part of this publication may be reproduced, stored in a retrieval system, or transmitted in any form or by any means, mechanical, photocopying, recording or otherwise, without the prior written permission of Ross Video. While every precaution has been taken in the preparation of this document, Ross Video assumes no responsibility for errors or omissions. Neither is any liability assumed for damages resulting from the use of the information contained herein.

Microsoft®, Windows®, and Windows XP® are either registered trademarks or trademarks of Microsoft Corporation in the United States and/or other countries.

Macintosh®, and OS X® are trademarks of Apple Inc., registered in the U.S. and other countries.

Google Chrome™, Google®, and the Google logo are registered trademarks of Google Inc.

NDI® is a registered trademark of NewTek, Inc.

## Patents

Patent numbers US 7,034,886; US 7,508,455; US 7,602,446; US 7,802,802 B2; US 7,834,886; US 7,914,332; US 8,307,284; US 8,407,374 B2; US 8,499,019 B2; US 8,519,949 B2; US 8,743,292 B2; US D752,530 S; GB 2,419,119 B; GB 2,447,380 B; and other patents pending.

## Important Regulatory and Safety Notices to Service Personnel

Before using this product and any associated equipment, refer to the “**Important Safety Instructions**” listed in the front of this manual to avoid personnel injury and to prevent product damage.

Product may require specific equipment, and/or installation procedures to be carried out to satisfy certain regulatory compliance requirements. Notices have been included in this publication to call attention to these specific requirements.

## Symbol Meanings



**Protective Earth:** This symbol identifies a Protective Earth (PE) terminal, which is provided for connection of the supply system's protective earth (green or green/yellow) conductor.



**Important:** This symbol on the equipment refers you to important operating and maintenance (servicing) instructions within the Product Manual Documentation. Failure to heed this information may present a major risk of damage or injury to persons or equipment.



**Warning:** The symbol with the word “Warning” within the equipment manual indicates a potentially hazardous situation which, if not avoided, could result in death or serious injury.



**CAUTION:** The symbol with the word “Caution” within the equipment manual indicates a potentially hazardous situation which, if not avoided, may result in minor or moderate injury. It may also be used to alert against unsafe practices.



**Warning Hazardous Voltages:** This symbol is intended to alert the user to the presence of uninsulated “dangerous voltage” within the product enclosure that may be of sufficient magnitude to constitute a risk of shock to persons.



**ESD Susceptibility:** This symbol is used to alert the user that an electrical or electronic device or assembly is susceptible to damage from an ESD event.

## Important Safety Instructions

1.  **Warning:** Read these instructions.
2. Keep these instructions.
3. Heed all warnings.
4. Follow all instructions.
5. Do not use this apparatus near water.
6. Clean only with a dry cloth.
7. Do not block any ventilation openings. Install in accordance with manufacturer's instructions.
8. Do not install near heat sources such as radiators, heat registers, stoves, or other apparatus (including amplifiers) that produce heat.

9. Do not defeat the safety purpose of the polarized or grounding-type plug. A polarized plug has two blades with one wider than the other. A grounding type plug has two blades and a third grounding prong. The third prong is provided for your safety. If the provided plug does not fit into your outlet, consult an electrician for replacement of the obsolete outlet.

10. Protect the power cord from being walked on or pinched, particularly at plugs, convenience receptacles, and the point where they exit from the apparatus.

11. Only use attachments/accessories specified by the manufacturer.

12. Unplug this apparatus during lightning storms or when unused for long periods of time.

13. Refer all servicing to qualified service personnel. Servicing is required when the apparatus has been damaged in any way, such as when the power-supply cord or plug is damaged, liquid has been spilled or objects have fallen into the apparatus, the apparatus has been exposed to rain or moisture, does not operate normally, or has been dropped.

14. Do not expose this apparatus to dripping or splashing, and ensure that no objects filled with liquids, such as vases, are placed on the apparatus.

15. To completely disconnect this apparatus from the AC Mains, disconnect the power supply cord plug from the AC receptacle.

16. The mains plug of the power supply cord shall remain readily operable.

17.  **Warning:** Indoor Use: To reduce the risk of fire or electric shock, do not expose this apparatus to rain or moisture.

18. The safe operation of this product requires that a protective earth connection be provided. A grounding conductor in the equipment's supply cord provides this protective earth. To reduce the risk of electrical shock to the operator and service personnel, this ground conductor must be connected to an earthed ground.

19.  **Warning:** This apparatus, when equipped with multiple power supplies, can generate high leakage currents. To reduce the risk of electric shock, ensure that each individual supply cord

is connected to its own separate branch circuit with an earth connection.

20.  **CAUTION:** These service instructions are for use by qualified service personnel only. To reduce the risk of electric shock, do not perform any servicing other than that contained in the operating instructions unless you are qualified to do so.

21. Service barriers within this product are intended to protect the operator and service personnel from hazardous voltages. For continued safety, replace all barriers after servicing.

22. Certain parts of this equipment still present a safety hazard with the power switch in the OFF position. To avoid electrical shock, disconnect all A/C power cords from the chassis' rear appliance connectors before servicing.

23. This product contains safety critical parts, which, if incorrectly replaced, may present a risk of fire or electrical shock. Components contained within the product's power supplies and power supply area are not intended to be customer-serviced and should be returned to the factory for repair.

24. To reduce the risk of fire, replacement fuses must be the same type and rating.

25. Use only power cords specified for this product and certified for the country of use.

26. The safe operation of this equipment requires that the user heed and adhere to all installation and servicing instruction contained within the equipment's Setup Manuals.

27.  **Warning:** This product includes "Ethernet Ports" which allow this product to be connected to local area networks (LAN). Only connect to networks that remain inside the building. Do not connect to networks that go outside the building.

28.  **CAUTION:** This apparatus contains a Lithium battery, which if replaced incorrectly, or with an incorrect type, may cause an explosion. Replace only with a CR2032 coin type lithium battery. Dispose of used batteries according to the manufacturer's instruction by qualified service personnel.

29.  **CAUTION:** Phantom Power can damage equipment if not supported. Ensure that Phantom Power is turned off for the Analog Input unless you are connecting a microphone that requires phantom power. Connecting the

line out from an audio device to the analog input with phantom power on could damage the audio device and/or the 1RU Audio Breakout Module. For added safety, a TRS phone connector should be used for line in audio sources.

30. For use at altitude 2000m or lower.

31. For use in non-tropical locations.

32.  **CAUTION:** Do not make mechanical or electrical modifications to the equipment or add metallic items, such as metallic foil labels, to the printed circuit boards. Modifications can impair regulatory compliance, or performance and may void your warranty.

## EMC Notices

### United States of America — FCC Part 15

This equipment has been tested and found to comply with the limits for a class A Digital device, pursuant to part 15 of the FCC Rules. These limits are designed to provide reasonable protection against harmful interference when the equipment is operated in a commercial environment. This equipment generates, uses, and can radiate radio frequency energy and, if not installed and used in accordance with the instruction manual, may cause harmful interference to radio communications. Operation of this equipment in a residential area is likely to cause harmful interference in which case the user will be required to correct the interference at his own expense.

 **Important:** Changes or modifications to this equipment not expressly approved by Ross Video Limited could void the user's authority to operate this equipment.

### Canada

This Class “A” digital apparatus complies with Canadian ICES-003.

Cet appareil numérique de la classe “A” est conforme a la norme NMB-003 du Canada.

### Korea — Class A Statement

이 기기는 업무용 환경에서 사용할 목적으로 적합성 평가를 받은 기기로서 가정용 환경에서 사용하는 경우 전파간섭의 우려가 있습니다.

This device has been evaluated for conformity for use in a business environment. When used in a home environment, there is a danger of interference.

## Europe

This equipment is in compliance with the essential requirements and other relevant provisions of **CE Directive 93/68/EEC**.

## International

This equipment has been tested to **CISPR 22:1997** along with amendments **A1:2000** and **A2:2002**, and found to comply with the limits for a Class A Digital device.

 **Important:** This is a Class A product. In domestic environments, this product may cause radio interference, in which case the user may have to take adequate measures.

## General Handling Guidelines

- Careful handling, using proper ESD precautions, must be observed.
- Power down the system before PCB removal.

## A Word About Static Discharge

Throughout the many procedures in this manual, please observe all static discharge precautions.

 **CAUTION:** Avoid handling the switcher circuit boards in high static environments such as carpeted areas, and when synthetic fiber clothing is worn. Touch the frame to dissipate static charge before removing boards from the frame, and exercise proper grounding precautions when working on circuit boards. Exercise proper grounding precautions when working on circuit boards.

## Warranty and Repair Policy

Ross Video Limited (Ross) warrants its switchers and related options, to be free from defects under normal use and service for a period of ONE YEAR from the date of shipment. Fader handle assemblies are warranted for the life of the product. If an item becomes defective within the warranty period Ross will repair or replace the defective item, as determined solely by Ross.

Warranty repairs will be conducted at Ross, with all shipping FOB Ross dock. If repairs are conducted at the customer site, reasonable out-of-pocket charges will apply. At the discretion of Ross, and on a temporary loan basis, plug in circuit boards or other replacement parts may be supplied free of charge while defective items undergo repair. Return packing, shipping, and special handling costs are the responsibility of the customer.

Software upgrades for switchers may occur from time to time, and are determined by Ross Video. The upgrades are posted on the Ross Video website, and are free of charge for the life of the switcher.

This warranty is void if products are subjected to misuse, neglect, accident, improper installation or application, or unauthorized modification.

In no event shall Ross Video Limited be liable for direct, indirect, special, incidental, or consequential damages (including loss of profit). Implied warranties, including that of merchantability and fitness for a particular purpose, are expressly limited to the duration of this warranty.

This warranty is TRANSFERABLE to subsequent owners, subject to Ross Video's notification of change of ownership.

## Environmental Information

### Waste Electrical and Electronic Equipment Directive (WEEE Directive)

**The equipment that you purchased required the extraction and use of natural resources for its production. It may contain hazardous substances that could impact health and the environment.**

To avoid the potential release of those substances into the environment and to diminish the need for the extraction of natural resources, Ross Video encourages you to use the appropriate take-back systems. These systems will reuse or recycle most of the materials from your end-of-life equipment in an environmentally friendly and health conscious manner.

The crossed-out wheeled bin symbol invites you to use these systems.



If you need more information on the collection, reuse, and recycling systems, please contact your local or regional waste administration.

You can also contact Ross Video for more information on the environmental performances of our products.

### Use of Hazardous Substances in Electrical and Electronic Products (China RoHS)

Ross Video Limited has reviewed all components and processes for compliance to:

“Management Methods for the Restriction of the Use of Hazardous Substances in Electrical and Electronic Products” also known as China RoHS.

The “Environmentally Friendly Use Period” (EFUP) and Hazardous Substance Tables have been established for all products. We are currently updating all of our Product Manuals.

The Hazardous substances tables are available on our website at: <http://www.rossvideo.com/about-ross/company-profile/green-practices/china-rohs.html>

### 电器电子产品中有毒物质的使用

Ross Video Limited 按照以下的标准对所有组件和流程进行了审查:

"电器电子产品有害物质限制使用管理办法" 也被称为中国RoHS。

所有产品都具有 "环保使用期限" (EFUP) 和有害物质表。目前, 我们正在更新我们所有的产品手册。

有害物质表在我们的网站:

<http://www.rossvideo.com/about-ross/company-profile/green-practices/china-rohs.html>

## Company Address

**Ross Video Limited** — 8 John Street Iroquois, Ontario, Canada, K0E 1K0

**Ross Video Incorporated** — P.O. Box 880, Ogdensburg, New York, USA, 13669-0880

General Business Office: (+1)613-652-4886

Fax: (+1)613-652-4425

Toll Free Technical Support (North America): 1-844-652-0645

Toll Free Technical Support (International): +800 1005 0100

Technical Support: (+1)613-652-4886

After Hours Emergency: (+1)613-349-0006

E-Mail (Support): [techsupport@rossvideo.com](mailto:techsupport@rossvideo.com)

E-Mail (General): [solutions@rossvideo.com](mailto:solutions@rossvideo.com)

## Technical Support

At Ross Video, we take pride in the quality of our products, but if a problem does occur, help is as close as the nearest telephone.

Our 24-Hour Hot Line service ensures you have access to technical expertise around the clock. After-sales service and technical support are provided directly by Ross Video personnel. During business hours (eastern standard time), technical support personnel are available by telephone. Outside of normal business hours and on weekends, a direct emergency technical support phone line is available. If the technical support personnel who is on call does not answer this line immediately, a voice message can be left and the call will be returned shortly. Our Technical support staff are available to react to any problem and to do whatever is necessary to ensure customer satisfaction.

## Supporting Documentation

Ross Video provides a wide variety of helpful documentation for the setup and support of your equipment. Most of this documentation can be found either on the Product Resources disk that came with your equipment, on the Ross Video website ([www.rossvideo.com](http://www.rossvideo.com)), or on the Ross Video Community site ([discussions.rossvideo.com/](http://discussions.rossvideo.com/))

- **Carbonite webhelp** — visit [help.rossvideo.com/carbonite](http://help.rossvideo.com/carbonite)
- **Manual (4841DR-110)** — setup and operation for the Carbonite Ultra switchers
- **Ultra QuickStart Poster (4841DR-200)** — setup information and specifications for the Carbonite Ultra frames
- **Upgrade Notes (4841DR-500)** — upgrade instructions, new features, and known issues for a given software version
- **Software Licenses (4841DR-502)** — third-party software licences
- **Carbonite Multilingual Safety Information (4802DR-503)** — translated product safety information
- **Device Setup** ([help.rossvideo.com/carbonite-device](http://help.rossvideo.com/carbonite-device)) — setup information for controlling external devices from the switcher

# Contents

	User Area.....	21
	Control Area.....	21
	Bus Area.....	22
<b>Features.....</b>	<b>13</b>	
Clean Feed Output.....	13	
Custom Controls.....	13	
Sequencer.....	13	
Device Control.....	13	
DVE (Fly Key).....	13	
Effects Dissolve.....	13	
General Purpose Interface (GPI).....	13	
LiveEDL.....	14	
Matte/Wash Generator.....	14	
ME Effect System.....	14	
Media-Store.....	14	
MediaManager.....	14	
MediaWipe.....	14	
Clip Player.....	14	
MemoryAI Recall Mode.....	14	
Memory System.....	14	
MiniME™.....	14	
UltraScene.....	15	
I/O Processor.....	15	
High Dynamic Range (HDR) and Wide Color Gamut (WCG) Conversion.....	15	
MultiScreen.....	15	
MultiViewer.....	15	
Output Rotation.....	16	
ViewControl.....	16	
OverDrive® Caprica Support.....	16	
Pattern and Matte/Wash Generators.....	16	
Tally Outputs.....	16	
UltraChrome.....	16	
XPression Live CG.....	16	
<b>Dashboard.....</b>	<b>17</b>	
Switcher Status in Dashboard.....	17	
Configuration.....	17	
Devices.....	17	
Live Assist.....	17	
PanelINK.....	17	
Custom Controls.....	18	
ViewControl.....	18	
MediaManager.....	18	
Personality.....	18	
Help.....	18	
Audio Mixer.....	18	
Menu Group Access.....	18	
To Set the Menu Access.....	19	
<b>Role Based Access Control.....</b>	<b>20</b>	
To Turn on Role Based Access Control for Ross Platform Manager.....	20	
<b>SoftPanel.....</b>	<b>21</b>	
Menu Area.....	21	
<b>Ultritouch.....</b>	<b>23</b>	
<b>Audio and Video Processing.....</b>	<b>24</b>	
Video Processing and Flow.....	24	
Audio Processing and Flow.....	24	
<b>Video Sources.....</b>	<b>25</b>	
To Select a Source on a Bus from DashBoard.....	25	
<b>Video Layering.....</b>	<b>26</b>	
Re-Entry.....	26	
To Re-Enter an ME.....	26	
FlexiClean Clean Feed.....	26	
<b>Video Preview.....</b>	<b>27</b>	
MultiViewer.....	27	
<b>Matte Source.....</b>	<b>28</b>	
To Set Up a Matte Color.....	28	
To Set Up a Wash.....	28	
<b>Copying.....</b>	<b>29</b>	
ME Copy.....	29	
To Copy an ME.....	29	
Key Copy.....	29	
To Copy a Key.....	29	
Key Swap.....	29	
To Perform a Key Swap.....	29	
<b>Transitions.....</b>	<b>30</b>	
Performing Transitions.....	30	
To Perform a Transition.....	30	
Cut Transitions.....	32	
Dissolve Transitions.....	32	
To Set Up a Dissolve.....	32	
WhiteFlash.....	32	
To Set Up a WhiteFlash.....	32	
Wipe Transitions.....	33	
To Set Up a Wipe.....	33	
DVE Transitions.....	33	
To Set Up a DVE Transition.....	33	
MediaWipe Transitions.....	34	
To Set Up a MediaWipe.....	34	
<b>Keying.....</b>	<b>36</b>	
Self Keys.....	36	
To Set Up a Self Key.....	36	



Auto Select Keys.....	36
To Set Up an Auto Select Key.....	37
UltraChrome 2 Chroma Key.....	37
To Set Up a Chroma Key.....	38
To Box Mask a Key.....	39
UltraChrome Best Practices.....	40
Chroma Key Tips and Tricks.....	41
DVE Keys.....	42
To Set Up a DVE Key.....	43
To Apply a DVE to a Key (Fly Key).....	43
To Apply a Border/Edge Softness to a DVE Key.....	44
To Apply Lighting to the DVE Border.....	45
Show Alpha.....	45
Masks.....	45
To Pattern Mask a Key (SD or HD Only).....	46
To Box Mask a Key.....	46
Split Keys.....	46
To Set Up a Split Key.....	46
<b>Memory Functions.....</b>	<b>48</b>
Storing Memories.....	48
To Store a Memory.....	48
Recalling Memories.....	48
Memory Attribute Color Coding.....	49
To Recall a Memory.....	49
Memory Attributes.....	50
To Set the Memory Attributes.....	50
Deleting a Memory.....	51
To Delete a Memory.....	51
Memory Names and Mnemonics (TouchDrive only).....	52
To Assign a Name to a Memory.....	52
<b>Audio Mixer.....</b>	<b>53</b>
Sample Rate Conversion.....	53
Audio Mixer Interface.....	53
Audio Mixer Setup.....	54
To Set the Number of Configurable Audio Faders (Channel).....	54
To Set Up Audio Faders.....	54
To Assign Audio Channels to Mix Layers.....	55
To Configure the Analog Inputs.....	56
To Configure the ABM Input Audio Delay.....	56
To Configure Audio Outputs.....	57
To Configure ABM Audio Outputs.....	57
Noise Gate.....	57
To Configure a Noise Gate.....	58
Ducking and Talkback.....	58
Ducking.....	58
Talkback.....	59
Audio Equalization.....	60
To Configure an Equalizer.....	60
Compressor / Limiter.....	61
To Configure a Compressor/Limiter.....	61

## Switcher Sets.....63

To Store a Set.....	63
To Load a Set.....	63
Importing a Set from Carbonite.....	64
To Import a Set from Carbonite.....	65

## Media-Store.....66

Working With Media-Store Animations.....	66
Working With Media-Store Audio.....	66
Media-Store Cache Manager.....	67
Media-Store File Specifications.....	67
Animation File Size.....	67
Loading Stills or Animations.....	68
To Load a Media Item.....	68
Deleting a Media Item.....	68
To Delete A Media Item.....	68
MediaManager Channel Control.....	68
Media-Store Attributes.....	69
Media-Store Capture.....	69
To Capture a Still.....	70

## Clip Player.....71

Clip Specifications.....	71
Clip Player Interface.....	72
To Load a Clip.....	72

## Custom Controls.....74

Recording/Editing Custom Controls.....	74
To Record a Custom Control.....	74
To Edit a Custom Control.....	74
Custom Control Pause Mode.....	75
To Set the CC Pause Mode.....	75
Running a Custom Control.....	75
To Run a Custom Control.....	76
Custom Control Names and Mnemonics.....	76
To Name a Custom Control.....	76
Deleting a Custom Control.....	77
To Delete a Custom Control.....	77
Copying and Pasting a Custom Control.....	77
To Copy and Paste a Custom Control.....	77

## Sequencer.....78

Creating/Editing Sequences.....	78
To Create/Edit a Sequence.....	78
Loading and Running a Sequence.....	79
To Load a Sequence.....	79
To Run a Sequence.....	79
Sequence Names and Mnemonics.....	79
To Name a Sequence.....	79
Deleting a Sequence.....	80
To Delete a Sequence.....	80
Copying and Pasting a Sequence.....	80
To Copy and Paste a Sequence.....	80

	To Set Up a Pre-Tiled Source.....	99
<b>UltraScene.....</b>	<b>81</b>	
Scene Overview.....	81	
To Create a Scene.....	82	
UltraScene Memories.....	83	
To Store an UltraScene.....	83	
To Recall an UltraScene.....	83	
Naming an UltraScene Memory.....	83	
To Name an UltraScene Memory.....	83	
<b>Network Connections.....</b>	<b>85</b>	
Network Setup.....	85	
To Connect DashBoard to the Frame.....	85	
To Change the IP Address.....	86	
Ross Platform Manager Connections.....	86	
FTP Connection.....	86	
To Create an FTP Connection.....	86	
<b>Video Reference.....</b>	<b>88</b>	
Supported Reference Formats.....	88	
Switcher Modes.....	89	
To Set the Switcher Mode.....	89	
Switcher Mode Video Formats.....	89	
Switcher Mode Restrictions.....	90	
Reference and Video Mode Setup.....	90	
To Set a Video Mode.....	90	
Output Reference Synchronizers.....	91	
To Set Up an Output Reference Sync.....	91	
Switching Field (SD or HD Only) .....	91	
To Set the Switching Field.....	91	
<b>Video Inputs.....</b>	<b>93</b>	
UHDTV1 Inputs.....	93	
Video Input Setup.....	93	
To Set up an External Video Input.....	93	
To Set up an Internal Video Input.....	94	
Source Names.....	94	
To Set Up a Source Name.....	94	
To Assign a TSL ID to a Video Input.....	94	
Mnemonics.....	95	
To Customize Mnemonics for		
TouchDrive.....	95	
To Customize Mnemonics for Carbonite		
Black.....	95	
Auto Key Setup.....	96	
To Set Up an Auto Key Association.....	96	
GPI Device Control.....	96	
To Assign a GPI Output to a Video		
Source.....	97	
Tallies Setup.....	97	
To Assign a Tally to a Video Source.....	97	
Custom Page Auto Follow.....	97	
To Assign a Page to a Custom Page		
Button.....	98	
To Assign a Custom Page to Follow an		
Input.....	98	
Substitution Table.....	98	
<b>Video Outputs.....</b>	<b>100</b>	
UHDTV1 Outputs.....	100	
Video Output Setup.....	100	
To Set up a Video Output.....	100	
Output Rotation.....	101	
To Rotate a Video Output.....	101	
Ancillary Data.....	102	
To Strip or Pass Ancillary Data.....	102	
FlexiClean Clean Feed.....	102	
To Set Up Clean Feed.....	102	
External Layer Mode.....	103	
To Set Up Layer Mode.....	103	
ME Follows.....	103	
To Set Up an ME Follow.....	103	
On-Air Setting.....	104	
To Set the On-Air Status for an Output.....	104	
<b>MultiViewer.....</b>	<b>105</b>	
MultiViewer Output Formats.....	105	
To Set Up an I/O MultiViewer.....	106	
To Set Up a Video Processor MultiViewer.....	107	
MultiViewer Clock.....	108	
To Set Up a MultiViewer Timecode		
Clock.....	108	
To Set Up a MultiViewer System Clock.....	109	
To Set Up a MultiViewer Countdown		
Timer.....	109	
<b>MultiScreen.....</b>	<b>111</b>	
MultiScreen Video Processor Setup.....	111	
To Set Up MultiScreen.....	112	
To Set Up a Pre-Tiled Source.....	113	
<b>I/O Processors.....</b>	<b>114</b>	
To Assign an I/O Processor to an Input or Output (SD		
or HD Only).....	114	
<b>Frame Sync and Format Conversion.....</b>	<b>115</b>	
Supported FSFC Video Formats .....	115	
Input FSFC.....	117	
To Assign an FSFC to an Input (UHDTV1		
Only).....	117	
To Set Up an Input FSFC (SD or HD		
Only).....	117	
To Set Up an Input FSFC (UHDTV1		
Only).....	118	
Output FSFC.....	118	
To Assign an FC to an Output (UHDTV1		
Only).....	118	
To Set Up an Output FSFC (SD or HD).....	118	
To Set Up an Output FC (UHDTV1).....	119	
Aspect Ratio Conversion.....	119	
Full.....	119	
Zoom.....	119	

Letterbox.....	119	To Set Up a GPI Output.....	134
Pillarbox.....	119		
<b>Frame Delays (HD and UHDTV1 Only) .....</b>	<b>120</b>		
To Apply a Frame Delay to an Input.....	120		
<b>System Real-Time Clock/Date.....</b>	<b>121</b>		
To Set the System Real-Time Time and Date.....	121		
<b>Audio Breakout Module Setup.....</b>	<b>122</b>		
To Set Up Multiple 1RU Audio Breakout Modules.....	122		
<b>AES Audio Output.....</b>	<b>123</b>		
To Assign Audio to an AES Output.....	123		
<b>Color Correction.....</b>	<b>124</b>		
To Assign a Color Corrector to a Source (UHDTV1 Only).....	124		
Proc Amp Color Correction.....	124		
To Apply a Proc Amp to a Video Source.....	124		
RGB Color Correction .....	125		
To Apply RGB Color Correction to a Video Source.....	125		
High Dynamic Range (HDR) and Wide Color Gamut (WCG) Conversion.....	125		
Supported HDR and WCG Conversion.....	125		
To Set the Switcher Dynamic Range and Color Gamut.....	126		
To Set the Video Input Dynamic Range and Color Gamut.....	126		
To Set the Video Output Dynamic Range and Color Gamut.....	127		
<b>Personality.....</b>	<b>128</b>		
Personality Settings.....	128		
General Settings.....	128		
Transition Settings.....	129		
Color Schemes.....	130		
To Select a Color Scheme.....	130		
To Create a Custom Color Scheme.....	130		
Bus Maps.....	130		
To Create a Bus Map.....	131		
User Buttons.....	131		
To Set A User Button.....	131		
<b>Licenses.....</b>	<b>132</b>		
To Add a License.....	132		
<b>GPI Control.....</b>	<b>133</b>		
GPI Trigger Types.....	133		
GPI Setup.....	133		
To Set Up a GPI Input.....	133		
		<b>Live Edit Decision Lists (LiveEDL).....</b>	<b>135</b>
		LiveEDL Setup.....	135
		To Set the LiveEDL Behavior.....	135
		Timecode Setup.....	135
		To Confirm External LTC Signal.....	135
		To Set Up Communications with a TSC-9902.....	135
		To Set the LTC Timecode Source.....	136
		LiveEDL Data Capture.....	136
		To Start Capturing EDL Data.....	136
		To Stop Capturing and Save EDL Data.....	137
		<b>ViewControl (HD or UHD Only) .....</b>	<b>138</b>
		ViewControl Overview.....	138
		Custom Control Buttons.....	138
		Bus Selection Buttons.....	138
		Keyer Transition Buttons.....	138
		Transition Buttons.....	138
		Custom Control Button Setup.....	139
		To Set up the Custom Control Buttons.....	139
		ViewControl Setup.....	139
		Connecting ViewControl over HDMI™ .....	139
		Connecting ViewControl over NDI® .....	140
		<b>MultiPanel.....</b>	<b>143</b>
		To Set Up MultiPanel Permissions.....	143
		<b>MIDI Controller.....</b>	<b>144</b>
		To Connect the X-TOUCH COMPACT to DashBoard.....	144
		To Configure the X-TOUCH COMPACT Interface.....	144
		To Configure the Button Layers on the X-TOUCH COMPACT.....	144
		To Map Buttons to Functions.....	145
		Default X-TOUCH COMPACT Mapping.....	145
		Custom Mapping.....	145
		To Create a Custom Button Mapping.....	146
		<b>Diagnostics.....</b>	<b>148</b>
		Switcher Status.....	148
		Switcher Information Text File.....	148
		Switcher Logs.....	149
		To Copy Logs to a USB.....	149
		Diagnostic Tests.....	149
		To Run the Tally Test.....	149
		To Run the GPI Input Test.....	149
		To Run the GPI Output Test.....	149
		To Run the Control Panel Test.....	150
		To Run the LED Test.....	150
		To Run the Display Test.....	150
		Error Messages.....	150
		Switcher Reset.....	151
		Custom Reset Settings (RState).....	151
		Factory Default Settings.....	151

---

Frame DIP Switches.....	152
-------------------------	-----

<b>Index.....</b>	<b>228</b>
-------------------	------------

**Software Upgrade.....153**

To Upgrade the Switcher Software.....	153
---------------------------------------	-----

**Specifications.....154**

Resources.....	154
Hardware Weights.....	155
Environmental Characteristics.....	155
Video Input Specifications.....	155
Video Output Specifications.....	155
Audio Specifications.....	156
ABM Analog Audio Input Specifications.....	156
ABM Analog Audio Output Specifications.....	156
Jitter.....	156
System Timing.....	156
Network Ports.....	157
Power Consumption — Frame.....	157
Embedded Audio Assignment.....	157
Frame Ports.....	158
Serial Port.....	158
GPI Port.....	158
Tally Port.....	158
AES Port.....	159
LTC Port.....	159

**Custom Control Events.....160**

Operations Custom Controls.....	160
Canvas (BKGD DVE).....	160
Custom Control Events.....	161
Keyer.....	162
Media-Store.....	171
Matte.....	175
Sequencer.....	176
Special.....	176
Switcher Operation.....	177
Transitions.....	178
UltraScene.....	185
Personality Custom Controls.....	186
Personality.....	186
Installation Custom Controls.....	187
Switcher Installation.....	187
MultiViewer.....	193
RAVE Audio Mixer Custom Controls.....	198
Audio Mixer (RAVE).....	198
Device Custom Controls.....	211
Audio Mixer (Device).....	211
Camera.....	212
GPI.....	213
PBus II.....	213
RossTalk.....	214
Video Server.....	220

**MIDI Device OID List.....222**

**Glossary.....225**

## Features

Thank you for buying a Ross Video Carbonite Ultra Series Multi-Definition Live Production Switcher. The Ultra series builds on the Ross Video reputation for designing switchers that fit the needs of any production environment.

## Clean Feed Output

Clean feed is typically used for bilingual and live-to-tape productions. It provides a second Program output that is derived from a different location than the standard program output. A frequent application is the recording of shows for later airing without call-in phone numbers inserted.

The clean feed output can come from before or between the keyers.

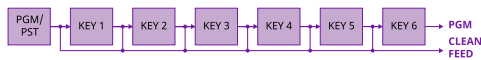

## Custom Controls

This feature brings the power of macros to the switcher operator. Button presses, menu selections, event commands, or even the switcher state can be recorded to a custom control with pauses or holds between the events. A simple button press can play these events back again. Step through complex show openings as easily as pressing Custom Control buttons 1, 2, then 3.

## Sequencer

The switcher has 5 Sequencers that allow you to create a playlist or rundown of custom events, much like custom controls. Each Sequencer can be run independently or linked to other Sequencers so that they all advance together. The Sequencer uses sequences to store the rundown of events. These sequence files can be loaded into one or multiple Sequencers.

**Tip:** You can link multiple Sequencers together so that as you advance through one, the other Sequencers will advance.

## Device Control

The switcher can control a number of external devices, such as video servers and robotic cameras. For a complete list of supported devices, and information on how to set up and control these devices, visit the Ross Video

website

([rossvideo.com/production-switchers/carbonite/interface-list](http://rossvideo.com/production-switchers/carbonite/interface-list)).

Device setup can be done through DashBoard.

## DVE (Fly Key)

The advanced 2D DVE comes standard with each switcher, and can be used for performing over the shoulder, or picture in picture shots. This allows all key types to be zoomed, cropped, and repositioned horizontally and vertically to create the look you want, or you can use one of the useful pre-built 2D effects to perform 2D background transitions.

## Effects Dissolve

The Effects Dissolve feature allows you to interpolate from one memory to another using a memory recall. The switcher will interpolate from the starting memory to the destination memory, creating a smooth, two key frame effect.

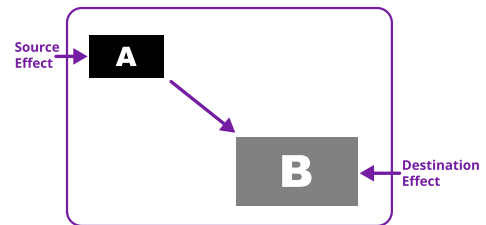

Only elements such as clip level and pattern position can be interpolated in the effects dissolve. Other elements, such as crosspoint selection, pattern, and next transition data are recalled first, and then the switcher will slew to the recalled memory.

An effects dissolve can be performed on as many elements and MEs as required, based on the memory that is being recalled.

## General Purpose Interface (GPI)

The switcher is equipped with 24 GPI I/Os that can be assigned as either an input or output independently.

The GPI inputs allow the switcher to interface with peripheral equipment such as editors. Each GPI input can be used to perform simple editing and switcher functions such as fade to black or an auto transition.

---

## LiveEDL

Edit Decision Lists (EDL) are files used by non-linear editing (NLE) suites to aid in post-production. Your switcher can capture EDL data in a file that you load into your NLE suite.

For information on using the LiveEDL feature, visit the Ross Video Website ([rossvideo.com](http://rossvideo.com)).

## Matte/Wash Generator

A matte generator and complex wash generator per ME, capable of multi-color washes comes standard. Any one of the color generators can be assigned to MATTE, or wipe pattern edges. An additional simple color generator is available for an Aux Bus.

## ME Effect System

The ME (Multi-level Effect) systems are standard. The number of MEs depends on the chosen switcher model.

Each ME provides independent keyers supporting pattern mask, box mask, self-key, linear key.

## Media-Store

Each channel of Media-Store provides a combined video with alpha for playout of stills and animations that are available switcher-wide, allowing for thousands of full screen stills and logos that can be cached and used on the switcher.

Media-Store provides 8 GB of cache. The number of images cached increases considerably when smaller, non-full screen images like logos are loaded from USB.

## MediaManager

The MediaManager allows you to easily manage stills and animations on the switcher in a graphics interface.

## MediaWipe

A MediaWipe allows you to use an animation, with audio, from the Media-Store to play over a background or key transition. When the transition starts, the switcher plays the selected animation and audio over top of the background and keys that are being transitioned. A cut, dissolve, wipe, or DVE wipe is then performed layered under the animation to bring up the

next shot when the animation ends. The audio is played out one of the AES ports.

## Clip Player

The clip player offers a single playout channel for compressed MPEG-4 AVC (ITU-T H.264) that can be assigned as a source on any bus in the switcher. Basic transport controls can be performed manually from the **Clip Player** page, using custom controls, or through AMP commands.

*Note: The clip player is not available in UHDTV1.*

## MemoryAI Recall Mode

We take the guessing out of memory recalls by ensuring that a memory recall will not affect what is currently on-air. MemoryAI uses the content of the memory to configure the Next Transition area and Preview bus for the background and keyers so that the next transition takes the same sources on-air that were on-air in the memory.

For example, store a memory that has a key on-air with CAM1 and CAM2 selected on the background. When this memory is recalled normally, it pops the same key on-air with CAM1 and CAM2 on the background. When the memory is recalled with MemoryAI turned on, CAM1 is selected on the preset bus, and CAM2 is selected on a key that is not on-air. The transition area is then set up for a background transition to bring CAM2 onto the background, take any on-air keys off, and take a key on-air with CAM1.

## Memory System

Storage for 100 complete switcher snapshots per ME, MiniME™, and Canvas comes standard with all switchers. All of these memories can be stored to a USB media drive, providing custom tailored memories for every operator and every show.

## MiniME™

The MiniME™ is an additional ME that is provided with the switcher to perform basic dissolves and cuts. Each MiniME™ has keyer, background, and preset buses. Unlike a full ME, the MiniME™ only supports dissolves and cuts. The MiniME™ shares all the same sources as the ME.

## UltraScene

UltraScene provides a simplified interface for creating a show with multiple key layers and basic transitions. UltraScene consists of 4 scenes that share 8 layers in 4 layer pairs. Layers can only be added in pairs, so a scene can have 2, 4, 6, or 8 layers. Each layer is set up like a keyer with a video source, alpha, and key type. Each layer can also be turned on or off to cut the video source on or off-air. A background source is also available over which the layers are keyed, or the scene can be taken as a source on bus.

## I/O Processor

The Input/Output Video Processors are independent video processing engines that allow you to perform a number of functions for video correction.

- Format Conversion (FC)
- Frame Synchronisation (FS)
- Color Correction
- Frame Delays (UHDTV1 only)

## High Dynamic Range (HDR) and Wide Color Gamut (WCG) Conversion

The RGB color correctors are used to convert between different SDR and HDR ranges and between color gamuts (WCG).

**Note:** HDR and WCG input conversion can only be applied in HD and UHD switcher modes.

**Note:** You must have available color correctors to be able perform the HDR/WCG conversion.

HDR and WCG conversion can be applied on the fly to input video signals, entire buses, or aux bus outputs.

To configure the dynamic range and color gamut conversion of input sources you must apply a color corrector to the input. This will convert the input source to the format that the switcher is operating in. Video signals can again be converted for individual output BNCs.

### Supported Color Gamuts:

- **BT.709** — color gamut recommended for HD video signals.
- **BT.2020** — wide color gamut recommended for UHDTV1 video signals.

### Supported Dynamic Ranges

- **SDR** — Standard Dynamic Range.
- **HLG** — Hybrid Log Gamma.
- **PQ** — Perceptual Quantizer.
- **S-Log3** — Sony® S-Log3.

## MultiScreen

The MultiScreen is made up of a number of Canvas generators. Each Canvas breaks the scene up into separate outputs (MiniME™ outputs) that can be sent to independent projectors or displays to make a unified picture.

Each screen in the Canvas output uses a MiniME™ to create the background and keys of the output.

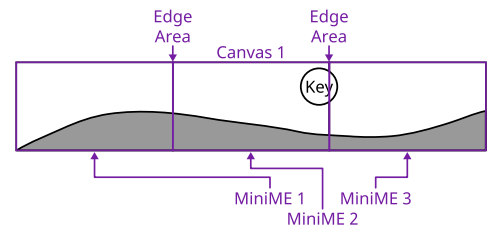

## MultiViewer

Each MultiViewer allows you to view up to 16 video sources (32 with Shift), in 51 different layouts, from a single output BNC. Any video source on the switcher, including ME Program, Preview, and Media-Store channels, can be routed to any box on the MultiViewer. All boxes on the MultiViewer output include mnemonic source names and red and green tallies.

The MultiViewer Shift features allows you to access a shifted set of sources for the MultiViewer by pressing the **SHIFT** button on a control panel or in ViewControl. The MultiViewer Shift functionality can only be assigned to a single panel at a time.

Each MultiViewer head supports an integrated clock that can display time of day, timecode, or a countdown timer. The position, size, and color of the clock can be adjusted.



Figure 1: HD Layouts



Figure 2: MultiViewer Grid

## Output Rotation

The output rotation allows you to rotate the video on outputs 12-14 in 90° increments clockwise. The video can then be zoomed and shifted in the X and Y axis.

**Tip:** The rotated output can be assigned to a box on the I/O MultiViewer.

**Note:** Output Rotation is only supported in the **ROT** switcher modes.

## ViewControl

The ViewControl touchscreen interface through DashBoard allows you to select sources on switcher buses, perform transitions, and run custom controls to recall memories or control external devices. The MultiViewer Shift function allows you to assign sources to a shifted set of MultiViewer boxes, expanding the number of sources available on ViewControl from 16 to 32.

**Tip:** It is recommended that the large Preview and Program boxes not be assigned shifted sources as they will follow the bus selecting.

ViewControl takes the MultiViewer output of the switcher and overlays the DashBoard interface over it. Bringing the MultiViewer output into DashBoard is accomplished either by using multiple SDI/HDMI™ converters or a single SDI to NDI® converter.

## OverDrive® Caprica Support

Ultra can be controlled from OverDrive® using the Caprica interface. This interface allows OverDrive® to perform memory recalls, transitions, and run custom controls on the switcher. For information on setting up Caprica to interface with the switcher, refer to the documentation that came with your Caprica server.

It is recommended to have 3 MEs installed to be controlled by Caprica, but operation is possible with only 2 MEs.

## Pattern and Matte/Wash Generators

A single pattern generator dedicated to wipes comes standard, and is equipped with 10 classic wipes. Most wipes can be rotated, bordered, multiplied, aspectized, and repositioned.

**Note:** The wash generator is not available in UHDTV1.

## Tally Outputs

The switcher has 24 assignable tally relays located in the rack frame. Each tally can be assigned to any number of combinations of input and output or bus.

## UltraChrome

The UltraChrome 2 chroma keyer uses independent chroma key engines to produce the video and alpha components of the key. These internal video streams can be composited in a keyer, or fed out two separate video streams to an external device, such as a video server.

## XPression Live CG

Seamlessly combine the creative power of the Ross® XPression Designer software with the ease of use of your Ross® switcher. Create stunning still graphics using XPression Designer, and transfer them directly to a media-store channel on the switcher using the RossLinq interface. Up to four (4) channels with dedicated alpha can be controlled from the XPression Software Client. This feature supports still images only.

Each switcher comes with a single license of XPression. Additional licenses can be ordered.



# DashBoard

DashBoard provides the main menu system to the switcher.

Download and install the latest version of DashBoard from <http://www.opengear.tv/>. Review the documentation that comes with DashBoard for information on installing and launching DashBoard.

**Note:** Ultra requires DashBoard v9.1, or higher.

**Tip:** You can also connect to the switcher from an Ultritouch using DashBoard. Refer to [Ultritouch](#) on page 23 for more information.

**Tip:** If DashBoard is having connection issues you can force DashBoard to reconnect to all devices from the 3-knob menu of TouchDrive or SoftPanel (Press **MENU** > **Reset** > **NEXT** > **NEXT** > **NEXT** > **NEXT** > **DashBoard Reboot**).

## Switcher Status in DashBoard

The DashBoard control system allows you to connect to the switcher and view status information for various components of the frame.



**Tip:** If the TouchDrive control panel is connected to the switcher, an additional tab for **Panel** is available that shows internal temperatures for that panel.

## Configuration

The Configuration node provides access to switcher settings such as Reference, Inputs, Outputs, and MultiViewer. You can switch between the different configurations by selecting the pages at the bottom of the DashBoard window.



## Devices

The Devices page on the Configuration node allows you to configure external devices to be controlled by the switcher.



**Tip:** Click **Disable Device** to disable the selected device (does not apply to Audio Mixers).

## Live Assist

The Live Assist node provides access to operational functions such as keying, transition, and memory settings of the switcher. You can switch between the different settings by selecting the tabs at the bottom of the DashBoard window.



**Tip:** The **Custom View** button on the **Live Assist** page opens a separate page where you can set up custom DashBoard pages. These custom pages can also be set to auto follow specific video sources. This allows you to have Live Assist show a specific custom page when a video source is selected.

**Tip:** You can quickly jump to Live Assist from any other page using the **Live Assist** button next to the **Navigation Menu** button at the bottom right corner of all non-Live Assist pages.

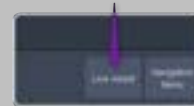

## PanelINK

PanelLink allows Live Assist to follow the button presses on the control panel and display the relevant tabs. For example, with **PanelINK** turned on, press **SEL** for any keyer and Live Assist shows the settings for that keyer. Press the **WIPE** buttons and Live Assist shows the transitions settings for a wipe. With **PanelINK** turned off, Live Assist does not switch between tabs.

**Note:** The PaneLINK feature controls which DashBoard page or tab is shown. Turning PaneLINK off does not lock the DashBoard menu and the current settings will update as selections are made on DashBoard or the control panel. For example, with PaneLINK on selecting a keyer displays the Live Assist tab for that keyer. Select a different key type from the panel and the DashBoard menu changes to show the settings for that key type. If you turn PaneLINK off, the DashBoard menu will continue to change with the different key types, but will not change to the Trans tab if you press a transition type button on the panel.



**Note:** PaneLink only works on the Live Assist page.

## Custom Controls

The Custom Control provides access to recording, editing, and running custom controls, as well as setting up the mnemonics for custom control on the TouchDrive control panel.



## ViewControl

The ViewControl interface through DashBoard allows you to coordinate the control over the switcher through a touchscreen interface. Through ViewControl you can select sources, perform transitions, and run custom controls.



## MediaManager

The MediaManager node allows you to control the Media-Store of the switcher. Upload media items, load media to channels, and set database elements..



## Personality

The Personality node provides the switcher personality settings.



## Help

The help node in DashBoard launches the integrated help system with full search capability.

## Audio Mixer

The audio mixer node in DashBoard provides access to the RAVE audio mixer. An audio channel must be routed to the switcher subsystem to be controllable by the audio mixer interface. Audio sources can come from the embedded audio on an input BNC, through the 1RU Audio Breakout Module, from the Media-Store, or from the Windows® sound mixer.



## Menu Group Access

Disable certain menu groups to improve DashBoard performance.

Menu group access disables certain DashBoard menu groups for the DashBoard port (5253, 5255, 5256, or 5257) that you are using. When a menu group is disabled, the data for those menus are not sent to that port. Without the data the menus are grayed out and the nodes do not appear in the DashBoard tree view.

## Keep the following in mind:

Keep the following in mind when working with the menu group access:

- When you disable a menu group, the data for those menus are no longer sent to any DashBoard on the same port as you. This can greatly speed up DashBoard connection times.
- When you change a menu access setting, all DashBoard connections, on all ports, to that frame are reset and reconnect.
- If you disable a menu group, any controls on a CustomPanel that were added from that port will no longer function.
- If you are connecting to the switcher using Caprica or Lightning you should set all menu groups to **On** for the port they are connecting on.
- You cannot disable the Personality menu.
- The menu access settings are not stored with Personality in a switcher set.
- Menu access settings are persistent after a factory default.
- Any change to the menu access resets all DashBoard connections to the frame on all ports.
- A list of all DashBoard connection to the frame and the ports they are using is shown on the **Status** menu.

## To Set the Menu Access

Set menu access for all DashBoard connections on the same port.



**Important:** Any change to the menu group access is applied to all DashBoard connections that are using that same port.



**Important:** If you change a menu group setting, all DashBoard connections to that frame, on all ports, are reset.

1. Click **Navigation Menu > Personality > Menu Group Access**.



2. Click a button next to the Menu Group item to enable (**On**) or disable (**Off**) that menu group.



**Important:** If you are connecting to the switcher using Caprica or Lightning you should set all menu groups to **On** for the port they are connecting on.

- **Configuration** — turn the **Configuration** menus on or off.
  - **Live Assist and Custom Control** — turn the **Live Assist** and **Custom Control** menus on or off.
  - **ViewControl** — turn the **ViewControl** node in the tree view on or off.
  - **Audio Mixer** — turn the **Audio Mixer** menu on or off.
3. Click **Save** to apply the changes to all DashBoard connections using the same port.
  4. Click **OK**.

## Role Based Access Control

The Ross Platform Manager allows for user authentication and role based access through DashBoard. Once set up in DashBoard, Ross Platform Manager allows for control over who can control Ultra based on the roles individual users are assigned to.

**Note:** Ross Platform Manager does not apply to operation of the switcher from a control panel.

**Tip:** For information on setting up a Ross Platform Manager server and creating user accounts, refer to the documentation that came with your Ross Platform Manager.

## To Turn on Role Based Access Control for Ross Platform Manager

From DashBoard you can select whether the Role Based Access Control (RBAC) of Ross Platform Manager is applied to Ultra.



**Important:** Changing the RBAC mode may restrict access to the switcher if your account is not assigned to a role that has the required permission.

**Note:** RBAC settings are not stored in switcher sets or changed with a factory default.

1. Click **Navigation Menu > Configuration > System > Global**



2. Click the **Authorized Connections** button and enter the IP address of any trusted DashBoard systems that you want to allow access to the switcher without RBAC permissions.

**Tip:** A common trusted system would be a TouchDrive control panel. This allows the control panel with a DashBoard interface to continue to control the switcher without the need for a user to log in.

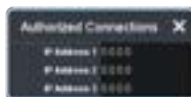

3. Click a **Role Based Access Control** button to apply access control to the switcher.
  - **Authorization not Required** — RBAC is applied to the switcher, but not enforced.

Anyone can control the switcher through DashBoard.

- **Authorization Required** — RBAC is applied to the switcher and enforced. Only users with permission can control the switcher through DashBoard.

4. Click **OK** to reboot the switcher using RBAC permissions from Ross Platform Manager.

**Tip:** You may have to close and re-launch DashBoard to apply the access control.

## SoftPanel

SoftPanel provides you with a graphical interface to the menu system and control surfaces of the switcher. This allows you to setup and control the switcher without a control panel.



**Important:** *SoftPanel is a separate panel connection to the frame. Refer to [MultiPanel](#) on page 143 for information on setting up SoftPanel.*

The screen can be broken up into several different functional areas. Each of these areas allows you to interact with different aspects of the switcher interface.

## Menu Area

The menu area provides a graphic representation of the menu system on a Carbonite Black control panel. The **Select**, **Up**, and **Down** buttons represent the actions of turning and pressing the knobs on the panel. The buttons in the top right corner allow you to navigate around in the menu tree, and the stylized mnemonic buttons at the bottom allow you to access different menus.



## User Area

The user area allows you to select what the bus area is assigned to, or interact with a virtual positioner. Press the **ME/Key**, **Aux Bus**, or **Positioner** button to select how the user area appears.

The **ME/Key** button allows you to select what the bus area is assigned to. Click **ME X**, **MiniME X**, **Canvas X**, or **CK** (chroma key) to assign the bus area to that output. Click one of the **Key X Sel** buttons to assign the key bus in the bus area to that key.



The **Aux Bus** button allows you to select one of the aux buses that the key bus row in the bus area is assigned to.

**Note:** *The selection of one of the aux bus or key select buttons indicated what the key bus in the bus area is assigned to. You may have to switch between the **ME/Key** and **Aux Bus** buttons to see where the bus is assigned.*



The **Positioner** button provides a virtual interface to the positioner. The positioner is used in device bus, or to move keys or masks around. Click and hold the positioner and move it around to emulate moving the positioner around. The slider to the right of the positioner emulated twisting the positioner knob on the panel. The button to the left of the positioner emulates the button on the top of the positioner knob on the panel.



## Control Area

The control area (the upper right of the screen) contains the main Dashboard interface to the switcher. Click **Navigation Menu** and select the menu you want to navigate to. When the **Live Assist** menu is selected, the sub-menus will follow actions in the bus area when **PanelINK** is on.

---

## Bus Area

The bus area provides a graphic representation of the panel row on the switcher. Use the user area buttons to assign the bus area to an ME, key, and aux bus. Sources are then selected on the key, program, and preset buses, and transitions are set up and performed with the transition buttons to the right of the source selection buttons.

*Tip: Use the **Hold On** or **2Press** buttons to emulate a press and hold of a button. This allows you to press and hold one button and then press another.*



# Ultritouch

The 2RU rack mountable Ultritouch adaptable system control panel allows you to control some aspects of switcher operation using a DashBoard interface.

The DashBoard interface on Ultritouch provides status, buses, and custom control tabs. You must connect to the switcher from Ultritouch to be able to control the switcher functions. Refer to the Ultritouch documentation for information on navigating the Ultritouch menu and manually connecting to a device.

Once you are connected to the switcher, tap the **Connected Devices** button and select the switcher you want to control from the list and tap **Carbonite**. The available tabs for the switcher are listed. Tap one of the available tabs to open it.



## Navigation Menu

Tap **Navigation Menu** and tap the tab you want to navigate to.

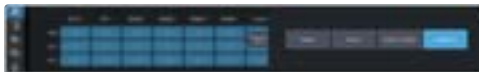

## Status

This tab allows you to view status information for various switcher components. These tabs are the same as the **Switcher Status** tab from a DashBoard computer.



## Buses

This tab allows you to select sources on any bus on the switcher. This tab is the same as the **Bus Assignments** page from a DashBoard computer.

1. Tap the area and bus that you want to select a source on.

2. Tap the source that you want to select or tap **Exit** to close the popup.

*Tip: The currently selected bus is shown at the upper left of the popup.*



## Custom Control

This tab allows you to run custom controls on the switcher. This tab is the same as the **Custom Control ShotBox** tab from a DashBoard computer. You cannot edit a custom control from this tab.

1. Tap the bank for the custom control you want to run.
2. Tap the custom control on the selected bank that you want to run.

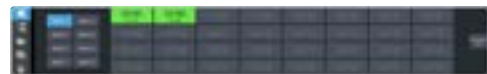

## MultiPanel

This tab allows you to set MultiPanel permissions.



# Audio and Video Processing

Video and audio signals are processed and passed through the switcher in different ways, depending on how the switcher is being used or is set up. A better understanding of how the switcher is processing these signals help you to achieve the production you want.

## Video Processing and Flow

Video is processed in a number of blocks in the switcher. After video comes into the switcher, the frame synchronizers / format converters are applied (depending on the frame you have). At this point any required color correction is also applied. After input the video signal is routed through the crosspoint. The crosspoint can route any input to any output for straight switching, or to the video processor and DVE and back for video manipulation. Just before the video signal is sent to the output, the processing of the ancillary data is performed.

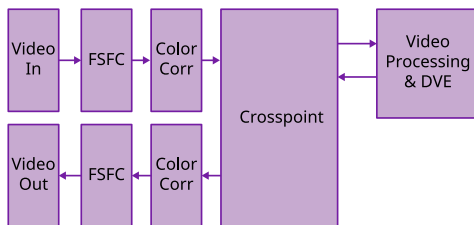

Figure 3: Video Flow Through the Switcher

## Audio Processing and Flow

An audio signal is embedded into the ancillary data of a video signal before it comes into the switcher. This includes both standard embedded audio that comes from external sources and the audio sources from the 1RU Audio Breakout Module. These audio sources are then brought into the audio mixer where they can be mixed and re-embedded on an output video signal.

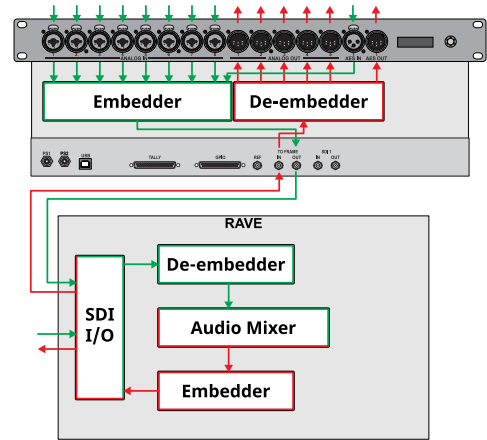

Figure 4: Analog Audio Flow Through the Switcher

As the embedded audio signal comes into the switcher and is manipulated, you must ensure not to perform an operation that will force the ancillary data to be stripped. Once an audio signal is in the switcher the audio mixer is able to manipulate and re-embed it in the video signal. Pass-through embedded audio can be stripped from the ancillary data if the video source is manipulated.

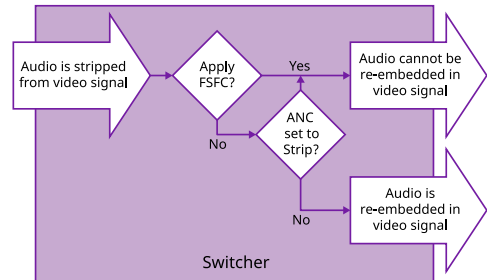

Figure 5: Embedded Audio Flow Through the Switcher

The following restrictions apply to ancillary data being included in the output:

- All ME program buses pass ancillary data.
- MultiViewer outputs do not include any ancillary data.
- Any format conversion on the input video signal.
- UHD-2SI or UHD-QSD on inputs 3 and 8.
- Setting ancillary data to be stripped.



---

## Video Sources

The switcher has access to three basic types of video sources, external, internal, and follows.

All video sources can be assigned to video source buttons. By pressing a video source button on a bus, the video source assigned to that button is selected on that bus.

- **External** — External video sources come from cameras, video servers, character generators, or other external devices into the switcher.
- **Internal** — Internal video sources come from internally generated video, such as Media-Store channels, matte color, and black.
- **Follows** — Follow video sources allow you to have one bus follow what is selected on another bus. For example, you can assign an Aux Bus to follow an ME Background so that a source selected on the background bus of that ME is also selected on the Aux Bus.

### To Select a Source on a Bus from Dashboard

To select a video source on a bus, you must identify the ME, MiniME™, Aux, Canvas, or chroma key and bus you want to assign a video source to, and then press the source button you want to select on that bus.

1. Click **Navigation Menu > Live Assist > Buses**.



2. Click **ME Bus, Chr Key Bus, or Aux Bus** to select the area that you want to select a source on. As you select different areas, the buses for that area are listed on the row above.
3. Click **MEX, MiniMEX, CanvasX, CKX, or AuxX** to select the specific bus or area you want to select a source on. With an ME, MiniME™, or Canvas there is an additional selection of the keyer, background, or preset bus that you want to select a source on. The chroma key and aux buses do not have these selections.

4. Select the background, preset, or keyer bus that you want to select a source on. (ME, MiniME™, and Canvas only)

**Note:** Ensure that the source selected on the bus you want to enter onto the ME, MiniME™, chroma key, Canvas, aux or keyer is valid for that destination. If the source is not valid, you will not be able to select the bus on the ME, MiniME™, Aux, chroma key, or keyer.

5. Select the type of source you want to assign to the bus and then select the source.
  - **Physical** — the sources on the physical input BNCs.
  - **Internal** — internally generated sources, including re-entries.
  - **Aux Follows** — use the source that is active on selected aux bus.
  - **ME Follows** — use the source that is active on selected ME bus.
  - **MiniME Follows** — use the source that is active on selected MiniME™ bus.
  - **Canvas Follows** — use the source that is active on selected Canvas bus.

# Video Layering

How video is layered in the output of the switcher depends on how an ME is re-entered onto the other, and what keyers are on-air for the ME.

If we assume that each ME has all keyers on-air and that ME 2 is re-entered into ME 1 and ME 1 is re-entered into ME P/P, the layering will start with ME 2 Background and progress to the highest ME and keyer.

**Tip:** If the switcher is in a 6 Key mode, there will be 6 keyers per ME and one less ME.

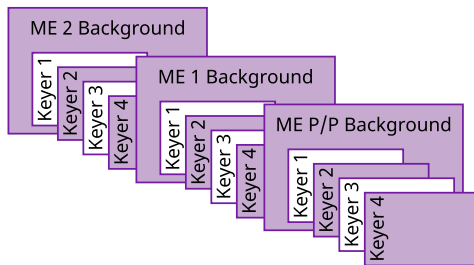

**Figure 6: Video Layering**

**Tip:** You can select a MiniME™ on an ME or different MiniME™ to re-enter it. Up to two MiniME™ re-entries, including an ME is allowed.

## Re-Entry

Re-entry is the term used to describe the process of selecting another ME on an ME. For example, if you select ME 2 on ME 1, ME 2 is said to be re-entered onto ME 1. Re-entry takes the output of an ME and uses it as the background or key on the other ME. If you select an ME on the background bus, the ME becomes background video source of the other ME. If you select an ME on a Key Bus, the ME becomes the key source of the other ME.

### Keep the following in mind:

Keep the following in mind when working with re-entries:

- You cannot re-enter an ME, or the Clean Feed of an ME, into itself.

### To Re-Enter an ME

The process to re-enter any bus onto another is the same as re-entering an ME onto another ME.

- Set up ME 2 with a background and a key.



- Set up ME P/P with a key.



- Select ME 2 as a source on the Background Bus of ME P/P. Notice that the output of ME 2 is now being used as the background of ME P/P.



## FlexiClean Clean Feed

FlexiClean provides a second program output that is derived from a different location than the standard program output. A frequent application is the recording of shows for later airing without call-in phone numbers inserted.

The clean feed output can come from before or between the keyers.

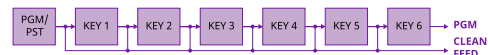

Refer to *FlexiClean Clean Feed* on page 102 for information on setting up a clean feed.

---

## Video Preview

Video preview allows you to use an additional monitor to preview what the next shot is going to be.

The preview for an ME shows what is selected for the next transition on that ME. This includes the keys and background video sources that will be on-air after the next transition.

## MultiViewer

Each MultiViewer allows you to view up to 16 video sources (32 with Shift), in 51 different layouts, from a single output BNC. Any video source on the switcher, including ME Program, Preview, and Media-Store channels, can be routed to any box on the MultiViewer. All boxes on the MultiViewer output include mnemonic source names and red and green tallies.

The MultiViewer Shift features allows you to access a shifted set of sources for the MultiViewer by pressing the **SHIFT** button on a control panel or in ViewControl. The MultiViewer Shift functionality can only be assigned to a single panel at a time.

Each MultiViewer head supports an integrated clock that can display time of day, timecode, or a countdown timer. The position, size, and color of the clock can be adjusted.

## Matte Source

Matte color backgrounds (**BG**) are color signals that can be applied to backgrounds and keys. Color selection is done either by picking a preset color, or by adjusted hue, saturation, and luminance to create a custom color.

Select the matte generator (**BG**) on a background or key bus. The full region of the background or key is filled with the selected color.

*Note: A color background can be a solid color, or a wash of two colors.*

### To Set Up a Matte Color

1. Click **Navigation Menu > Live Assist > Matte**.



2. Select the matte generator that you want to set the color for.
  - **ME X** — set the color for the color background source on the selected ME.
  - **Global** — set the color for the global matte generator.
3. Click one of the preset colors to assign that color to the selected matte generator.

*Tip: You can select a custom color by clicking the color box to the right of the preset colors and selecting a new custom color. Toggle **Live** on to show the color changes live on the matte generator source.*

### To Set Up a Wash

A wash applies colors to a pattern selected for a matte. The first color is preset to the matte color, but both are selectable. Selecting the source button again, or **KEY SEL** button returns to this menu. Refer to the sections on mattes and patterns for information on setting them up. You can load a preset color instead of creating the first custom color.



*Important: A control panel is required to perform this procedure. If you do not have access to a physical control panel, the SoftPanel can be used. The position of items on the menus on the SoftPanel may not match those of a physical panel.*

1. Use the **Hue 1** knob to adjust the hue of the first custom color.
2. Use the **Sat 1** knob to adjust the saturation of the first custom color.
3. Use the **Lum 1** knob to adjust the luminance of the first custom color.
4. Press **NEXT**.
5. Use the **Wash** knob to select **On**.
6. Press **NEXT**.
7. Use the **Size** knob to select the size of the wash pattern.
8. Press **NEXT > NEXT > NEXT > NEXT**.
9. Use the **Hue 2** knob to adjust the hue of the second custom color.
10. Use the **Sat 2** knob to adjust the saturation of the second custom color.
11. Use the **Lum 2** knob to adjust the luminance of the second custom color.

## Copying

You can copy the content of an ME or keyer to another ME or keyer.

### ME Copy

You can copy the entire contents of an ME, MiniME™, scene, or Canvas to another ME, MiniME™, scene, or Canvas. The entire contents of the destination is replaced with the contents of the source.

When you copy an ME, the switcher tries to assign resources to the destination ME to match the source ME. If these resources are not available, the switcher may need to steal resources.

#### To Copy an ME

Copy the contents of an ME to another.

1. Click **Navigation Menu > Live Assist > Copy > ME Copy**.



2. Click a **Destination** button to select the destination that you want to copy to.
3. Click a **Source** button to select the source you want to copy.
4. Click **Copy**.

### Key Copy

You can copy the entire contents of a keyer or layer to another keyer or layer in the same, or a different ME. The entire contents of the destination keyer are replaced with the contents of the source keyer.

When you copy a key or layer, the switcher tries to assign resources to the destination key to match the source key. If these resources are not available, the switcher steals resources from the highest numbered key that isn't on-air. If all the resources are used by on-air keys, the copy will not take the resource.

#### To Copy a Key

Copy the contents of a keyer or layer to another.

1. Click **Navigation Menu > Live Assist > Copy > Key Copy**.



2. Click an **ME Destination** and **Key Destination** button to select the destination that you want to copy to.
3. Click an **ME Source** and **Key Source** button to select the source you want to copy.
4. Click **Copy**.

### Key Swap

You can swap the entire contents of any two keyers in the same, or different MEs. The video source, position, and key type are all swapped between keyers. This allows you to change the apparent key priority, or layering, of the keys in the video output. For example, key 3 appears over key 2. If you perform a swap between key 3 and key 2, it appears as if key 2 is now over key 3.

#### Keep the following in mind:

Keep the following in mind when performing a key swap:

- Key swap does not change the on-air status of a keyer.
- A key swap can be recorded as part of a custom control.

#### To Perform a Key Swap

This procedure swaps the contents of Key 2 and Key 3 as an example. Use the same procedure for any key combination.



**Important:** A control panel is required to perform this procedure. If you do not have access to a physical control panel, the SoftPanel can be used. The position of items on the menus on the SoftPanel may not match those of a physical panel.

1. Press and hold the **KEY 2 SEL** button.
2. Press the **KEY 3** button in the transition area.

# Transitions

Transitions are used to change the background video and take keys on and off-air. A transition can include any combinations of background and keyers for an ME, MiniME™, or Canvas. The background and each keyer can be transitioned independently.

## Performing Transitions

What you can include in the transition, and the type of transition you can perform, depend on the number of resources you have, and if you are performing a background and keyer transition at the same time.

### Keep the following in mind:

Keep the following in mind when performing transitions:

- If any of the sources going on-air have an assigned GPI output, the GPI output is triggered and the switcher then waits the configured pre-delay interval before performing the transition. If you perform a transition with the fader handle, the GPI output is triggered but the pre-delay interval is ignored.
- If any of the sources going on-air are assigned to a video server, you can have the video server play when the source is taken on-air by toggling **Roll Clip** on.
- If any of the sources going on-air are assigned to a video server, the switcher waits for the configured pre-delay interval before performing the transition. If you perform a transition with the fader handle, the pre-delay interval is ignored.
- If the fader is moved during an auto transition, control of the transition is passed to the fader. You must complete the transition with the fader. This allows you to override any auto transition in progress with the fader.
- The **Cut** and **Auto** buttons can be used to transition keys independently.
- You can pause an auto transition by pressing the **Auto Trans** button during the transition. Press the button again to continue the transition.
- If you turn the Transition Limit off when the transition has stopped at the transition limit point, the next transition starts from the

transition limit point and goes forward to complete the transition, instead of going back to the start.

## To Perform a Transition

All transitions, with the exception of cuts on the background or key bus, have the same basic setup. The touchscreen menu system offers the touchscreen interface to setup and perform the transition.

1. Click **Navigation Menu > Live Assist > MEs.**



2. Click the **ME X, MiniME X, or Canvas X** for the area you want to perform the transition on.
3. Select the video sources you want to take on-air on each bus. Background and keys are set up slightly differently but can be performed with the same transition.
  - **Background** — click **Trans > Preset** and select the new background source.
  - **Key On-Air** — click the **Key X > Key Fill** button for the key you want to take on-air and select the new source. Repeat this for each key you want to take on-air.
  - **Key Off-Air** — you don't need to select the keys at this point.

*Tip: Refer to [To Select a Source on a Bus from DashBoard](#) on page 25 for information on selecting sources.*

4. Click **Trans.**
5. In the Next Transition area, select the elements (Background and Keys) you want to include in the next transition. You can include any combination of background and keys, but at least one element must be selected.



6. In the **Rate** field, enter the rate that you want the transition performed at. This is the speed, in frames, that it takes for the transition to complete. A Cut or manual fader transitions do not use the transition rate.

- **Background** — enter a new ME transition rate, in frames, in the **Trans Rate** field.
- **Key Only** — enter a new key transition rate, in frames, in the **Key X Rate** for the key you want to transition.

**Note:** The key rate is only used for key only transitions. Keys included in with the background are transitioned a the ME Rate.



7. In the Transition area, select the type of auto transition you want to perform. If you want to perform a cut you do not need to select a transition type and can move to the next step.

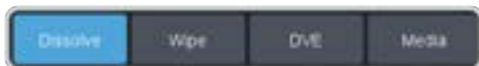

- **DISS** — perform a dissolve or WhiteFlash auto transition. Refer to [To Set Up a Dissolve](#) on page 32 or [To Set Up a WhiteFlash](#) on page 32 for more information.
- **WIPE** — perform a wipe auto transition. Refer to [To Set Up a Wipe](#) on page 33 for more information.
- **DVE** — perform a DVE auto transition. Refer to [To Set Up a DVE Transition](#) on page 33 for more information.
- **MEDIA WIPE** — perform a MediaWipe auto transition. Refer to [To Set Up a MediaWipe](#) on page 34 for more information.

8. Click a **Trans Settings** button to turn the setting on or off. The options available depend on the type of transition selected.



- **Roll Clip** — select whether you want any video server clips assigned to a source

being taken on-air to play with the transition (**On**), or not (**Off**).

- **Preview** — preview the transition on the preview output **On**. You cannot preview the independent key-only transitions or a MiniME™ transition.
- **Flip Flop** — select whether the wipe runs forward during the first transition and then reverse during the second (**On**), or if it always runs in the same direction (**Off**).
- **Direction** — select the direction that the wipe travels.

9. Click **Limit** to turn trans limit **On** or **Off**. Enter a value for the trans limit in the **Position** field to set the point in a transition where an auto transition stops. When active, the point in the transition where the auto transition will stop is indicated by a flashing segment on the transition progress bar next to the fader handle on the control panel. The auto transition proceeds to this point and stops. The second auto transition starts from the transition limit point and goes back to where the first transition started.



**Tip:** The **Limit Position** is a percentage with 0 being the starting point of the transition and 100 being the ending point of the transition.

10. Perform the transition.



**Important:** The **Cut** and **Auto** buttons trigger a transition on what has been selected. If **Trans** is selected a normal background transition is performed. If one of the keyers is selected (**Key X**) a key-only transition is performed on the selected key.

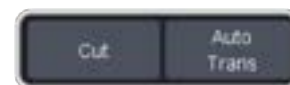

- **Auto Trans** — click **Auto Trans**
- **Cut** — click **Cut**

**Tip:** During an auto trans, press **Auto Trans** again to hold the transition at the current position or press **Cut** to abort the transition and return to the original source.

- If a pre-delay has been set, and **Roll Clip** is active, the switcher will apply the pre-delay interval before performing the transition.

## Cut Transitions

A Cut is an instantaneous transition between video sources. Unlike all the other transition types, there are no intermediate steps between the video source that is on-air, and the video source you are transitioning to.

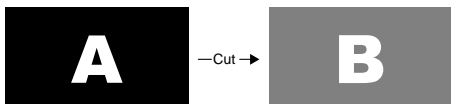

A cut is performed either by selecting different sources on a background or key bus, or by pressing a **Cut** button.

## Dissolve Transitions

A Dissolve is a gradual fade between video sources. For a Background transition, the video signal on the Background bus and the video signal on the Preset bus are mixed together until the Preset bus video signal completely replaces the Background bus video signal.



### To Set Up a Dissolve

A dissolve transition requires that you set a background and key transition rate for the auto transition. A fader transition does not use the transition rate.

- Click **Navigation Menu > Live Assist > MEs** and select the ME that you want to perform the transition on.

*Tip: You can use the same procedure for a MiniME™ or Canvas. You can use the same procedure for a MiniME™.*

- Click **Trans > Dissolve**, or press **DISS** in the **Transition** area on the control panel.



- Click **Dissolve**.

## WhiteFlash

Perform a two-step transition where a dissolve to and from white, or other selected color, is performed in the middle of the transition. The video signal on the Background bus is transitioned to a color background of the selected WhiteFlash color. The color background is then transitioned to the preset bus. WhiteFlash consumes a pattern generator for the transition.

Each ME has a separate WhiteFlash generator.

### To Set Up a WhiteFlash

A WhiteFlash transition is performed just like a normal dissolve except that you must set the color for the flash and the rates for the onset, hold, and fade.

- Click **Navigation Menu > Live Assist > MEs** and select the ME that you want to perform the transition on.

*Note: A WhiteFlash can only be performed on an ME.*

- Click **Trans > Dissolve**, or press **DISS** in the **Transition** area on the control panel.
- Click **Flash**.

*Tip: The DISS button on the control panel flashes indicating a WhiteFlash transition has been selected.*



- Use the **Onset %** and **Offset %** sliders to select the percentage of the transition that each phase of the WhiteFlash takes.
  - Onset** — duration of the dissolve to the WhiteFlash color.
  - Offset** — duration of the dissolve to the preset video source.
  - Hold** — duration of the dissolve that the WhiteFlash color is held. This value is the residual of entire duration minus the onset and offset.
- Select a default or custom color for the WhiteFlash.
  - Default** — click one of the preset matte colors.
  - Custom** — click the arrow to the right of the **Matte Color** area and use the **Hue**, **Saturation**, and **Lightness** sliders to



select your own color. Click **OK** to apply the color or **Live** to apply it in real-time.

## Wipe Transitions

A Wipe is a gradual transition where one video signal is replaced with another according to a wipe pattern. In the example below, a line wipe is being used.



For Key transitions, the key is wiped on or off-air with the transition and the background remains untouched. The duration of a wipe transition depends on either the transition rate for the ME, or the rate at which the fader is moved.

### To Set Up a Wipe

A wipe transition requires that you select a wipe pattern, set the direction and number/size of wipe pattern, as well as set a background and key transition rate for the auto transition. A fader transition does not use the transition rate.

1. Click **Navigation Menu > Live Assist > MEs** and select the ME that you want to perform the transition on.

*Note: A wipe can only be performed on an ME.*

2. Click **Trans > Wipe**, or press **WIPE** in the **Transition** area on the control panel.



3. In the **Wipe Pattern** area, select the pattern that you want to use for the wipe.
4. Set up the wipe pattern as required.
  - **Wipe Aspect** — adjust the aspect ratio of the wipe pattern. Not all patterns can be adjusted.
  - **H-Multiply** — multiply the pattern horizontally.
  - **V-Multiply** — multiply the pattern vertically.
  - **X-Position** — position the pattern on the x-axis.
  - **Y-Position** — position the pattern on the y-axis.

- **Rotation** — rotate the pattern. Not all pattern can be rotated.
- **Border Size** — apply a border to the pattern and adjust the size. At size 0 the border is off.
- **Border Softness** — apply softness to the border.
- **Border Color** — select a color for the border. You can choose between the predefined colors or use the color picker to select a custom color.

## DVE Transitions

A DVE transition is a gradual transition where one video signal is replaced with another according to a 2D DVE pattern.

### Keep the following in mind:

Keep the following in mind when performing DVE transitions:

- You must include the background when performing a DVE transition on a Chroma Key, Self Key, or Auto-Select Key. If you do not include the background, a dissolve transition is performed.
- Performing a DVE transition on a DVE Key without including the background scales the transition effect to the size of the DVE Key. This transition does not consume an additional DVE resource.
- Performing a DVE transition on a DVE Key with the background included does not scale the transition effect. This transition consumes the second DVE resource.
- You cannot perform a DVE transition on a Canvas.
- You can only perform a DVE transition on a DVE key on a MiniME™. If the transition includes the Background, or a keyer that is not set as a DVE, the transition is switched to a dissolve.

### To Set Up a DVE Transition

A DVE transition requires that you select the DVE pattern and duration for the transition.

1. Click **Navigation Menu > Live Assist > MEs** and select the ME that you want to perform the transition on.
2. Click **Trans > DVE**, or press **DVE** in the **Transition** area on the control panel.



3. Click a **DVE Pattern** button to select the DVE wipe pattern you want to use.

## MediaWipe Transitions

A MediaWipe allows you to use an animation to cover a transition. When the transition starts, the switcher plays the selected animation over top of the background and keys that are being transitioned. A MediaWipe can be used to cover a cut, dissolve, wipe, or DVE transition.

For a cut MediaWipe, the transition is performed when the cut point is reached. It is important to use a full-screen image in the animation at the cut point so that the cut is not visible on-air.

### Keep the following in mind:

Keep the following in mind when performing MediaWipe:

- Although you can select a still image for a media transition, it is not recommended.
- Only Auto Transition should be used for Media transitions. Using the fader to perform the transition manually could result in jumps in the animation.
- The duration of the transition (Time) is set by the length of the animation and the play speed of the animation.
- The audio associated with a MediaWipe is only available on the AES outputs.
- You cannot perform a MediaWipe transition on a MiniME™ or Canvas.
- Only Media-Store channels 1 and 2 can be used for a MediaWipe.
- The MediaWipe can be set to occur between any of the keys or the background. When you set the layer to a specific key, the MediaWipe animation will cover that key, even if the key is not part of the transition. The animation plays over the key, but the key remains after the animation is finished. Any keys above the MediaWipe layer remain on top of the animation.

## To Set Up a MediaWipe

A MediaWipe requires that you select the animation you want to use and then set up how you want the transition performed under the animation. This information is stored with the media item when you press save.

1. Click **Navigation Menu > Live Assist > MEs** and select the ME that you want to perform the transition on.
2. Click **Trans > Media**, or press **MEDIA** in the **Transition** area on the control panel.



3. In the **Media Status** area, click a **Media X** button to select the channel you want to assign an animation to.
4. In the **Media Selection** area, click the thumbnail box for the animation you want to assign to the Media-Store channel.

*Tip: Enter the media item number for a media item in the field below the thumbnail button assign that button to the media item.*

5. In the **Trans Layer** area, select where the MediaWipe will occur.
  - **Auto** — MediaWipe occurs over highest number key in the transition.
  - **Bkgd** — MediaWipe occurs over the background, but under all keys.
  - **Key1** — MediaWipe occurs over the background and key 1, but under remaining keys.
  - **Key2** — MediaWipe occurs over the background and key 1 and 2, but under remaining keys.
  - **Key3** — MediaWipe occurs over the background and key 1-3, but under key 4.
  - **Key4** — MediaWipe occurs over the background and key 1-4, but under key 5.
  - **Key5** — MediaWipe occurs over the background and key 1-5, but under key 6.
  - **Key6** — MediaWipe occurs over the background and all keys.



**Important:** If a key is above the MediaWipe layer and included in the MediaWipe transition, it will cut off-air with the transition. This is

---

*normally covered by the animation when the layer is above the key.*

6. Click **Edit Media Trans.**



7. In the **Media Over** area, select the type of transition you want to use under the MediaWipe. This also allows you to set up the transition parameters for wipes and DVE transitions.

8. Click **Trans Time** and use the slider or fader in the **Transition** area on the control panel to set the start and end of the transition under the MediaWipe.

- (Cut only) Use the **Cut Frame** slider to select the point for the cut, or move the fader to the point in the animation where you want the cut to happen and click **Cut at Fader Position**.
- Use the **Start Trans At** slider to select the point where the transition starts, or move the fader to the point in the animation where you want the transition to start and click **Start Trans at Fader Position**.
- Use the **Trans Rate** slider to select the duration of the dissolve, or move the fader to the point where you want the transition to end and click **End Trans at Fader Position**.

*Tip: If you select a negative start point for the transition, the transition will start first and then the animation will play after the start point duration has passed.*

9. Click **Thumbnail** and use the **Thumbnail** slider to select a point in the animation that you want to use as a thumbnail for the MediaWipe. You can also use the fader to select the position and click **Generate Thumbnail at Fader Position**.

10. Click **Save** to save the new setting to the selected media item.

11. Click **Exit Edit Media Trans.**

# Keying

Keying is the term used to describe when you insert (or electronically cut) portions of one scene into another, or place titles over background images. Keys are made up of two basic components, an alpha, that cuts the hole in the background video, and a fill, that fills the hole with different video.

Keys, like MEs, are layered onto the background video signal from the lowest numbered key to the highest on an ME.

**Note:** DashBoard Live Assist will not notify you of error messages or if a confirmation is required. For example, if there are no available resources for the DVE Key, or Chroma Key, you are trying to create, the switcher will not create the key and no notification will be shown.

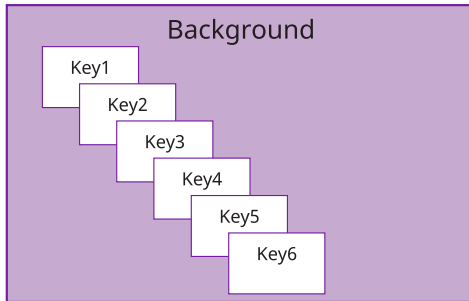

Figure 7: Key Priority

**Tip:** The Key Preview (**KEY PV**) button allows you to temporarily force the program output of the selected keyer to the preview output of the switcher. The ME remains in the key preview state for as long as you hold the **KEY PV** button, and returns to normal as soon as you release the button. You can also double-press the **KEY PV** button to latch the ME in the key preview state until the button is pressed again.

## Self Keys

A Self Key is a key in which the luminance, or brightness, values of the key source are used as the alpha for the key.

### To Set Up a Self Key

A self key is set up by selecting the keyer and video source you want to use, and adjusting the key parameters.

1. Click **Navigation Menu > Live Assist > MEs** and select the ME and key that you want to set up.

**Tip:** You can use the same procedure for a MiniME™ or Canvas. You can use the same procedure for a MiniME™.

2. Click **Key Fill** and select the video signal you want to use for the key.

3. Click **Self Key**.



**Tip:** Click **Show Alpha** to have the preview output of the current ME switch to the alpha signal that is being used by the selected keyer. Show alpha is not available for MiniME™ outputs.

**Tip:** Click **Key Preview** to force the program output of the selected keyer to the preview output of the switcher.

**Tip:** Click **Make Linear** to return the clip and gain values to the default settings.

4. Use the **Clip** slider to remove lower-saturated colors from the video image.
5. Use the **Gain** slider to adjust the transition between the video image and the parts of the video image that are removed.
6. Use the **Transparency** knob to adjust the transparency of the key from opaque (**0**) to fully transparent (**100**).
7. Click **Key Invert** to reverse the polarity of the key alpha so that the holes in the background are cut by dark areas of the key alpha instead of bright areas.
8. Click a **Keyer Mode** button to override the shaped setting for the key.
  - **Normal** — set to a linear keyer for an unshaped source.
  - **Additive** — set to an additive keyer for a shaped source. The **Key Invert** function is disabled in this mode.
  - **Full** — set the alpha to fully opaque (white). The **Clip**, **Gain**, **Make Linear**, and **Key Invert** functions are disabled in this mode.
9. Click **Mask** to apply a mask to the key.

## Auto Select Keys

An Auto Select key is a key in which two video signals are required to make the key. The alpha is used to cut the hole in the video and the fill is used to fill the hole. These signals often originate from external devices such as character generators, external still stores, or other graphics systems.

## To Set Up an Auto Select Key

An auto select key is set up by selecting the keyer and video source you want to use, and adjusting the key parameters. The pairing of the video and alpha video signals is done when configuring video inputs. Refer to the Setup Manual that came with your switcher for information on setting up Auto Keys.

1. Click **Navigation Menu** > **Live Assist** > **MEs** and select the ME and key that you want to set up.

**Tip:** You can use the same procedure for a MiniME™ or Canvas. You can use the same procedure for a MiniME™.

2. Click **Key Fill** and select the video signal you want to use for the key.
3. Click **Auto Select**.



**Tip:** Click **Show Alpha** to have the preview output of the current ME switch to the alpha signal that is being used by the selected keyer. Show alpha is not available for MiniME™ outputs.

**Tip:** Click **Key Preview** to force the program output of the selected keyer to the preview output of the switcher.

**Tip:** Click **Make Linear** to return the clip and gain values to the default settings.

4. Use the **Clip** slider to remove lower-saturated colors from the video image.
5. Use the **Gain** slider to adjust the transition between the video image and the parts of the video image that are removed.
6. Use the **Transparency** knob to adjust the transparency of the key from opaque (**0**) to fully transparent (**100**).
7. Click **Key Invert** to reverse the polarity of the key alpha so that the holes in the background are cut by dark areas of the key alpha instead of bright areas.
8. Click a **Keyer Mode** button to override the shaped setting for the key.
  - **Normal** — set to a linear keyer for an unshaped source.
  - **Additive** — set to an additive keyer for a shaped source. The **Key Invert** function is disabled in this mode.

- **Full** — set the alpha to fully opaque (white). The **Clip**, **Gain**, **Make Linear**, and **Key Invert** functions are disabled in this mode.

9. Click **Mask** to apply a mask to the key.

## UltraChrome 2 Chroma Key

An UltraChrome Chroma Key is a key in which the hole is cut based on a color value, or hue, rather than a luminance value or alpha signal. The color is removed and replaced with background video from another source. The default color is blue.

UltraChrome 2 can work in two modes, depending on the lighting conditions and subject matter used for the chroma key.

- **Wedge Key** — Based on the standard chroma keyer and discriminates between the color vector angle and level of the background color vs the color vectors and levels in the foreground components. This produces very good results under ideal conditions. However, if the scene includes high detail luma content in edge regions, these may not be included in the output.
- **Detail Key** — Differs from the standard chroma keyer in that it adds luminance dependency to a three-dimensional spherical color discriminator. This chroma keyer can develop subtle video and alpha shapes and discriminate high detail luma content in edge transition areas. However, this design may have problems with content where background and foreground levels are similar within the video itself.

**Tip:** UltraChrome 2 also offers the option to combine these two modes to offer good capture of high luma detail in the edge regions as well as compensation for similar foreground and background levels.

UltraChrome 2 includes unique **Automatic Background Analysis** that can develop key edges with luma values consistent with those of the new background - eliminating the light or dark key halos. In addition, background color values are averaged and can be applied to spill areas to add lighting realism to the final composition.

The UltraChrome 2 chroma keyer uses an independent chroma key engine to produce the video and alpha components of the key. These internal video streams can be composited in an ME or MiniME™ keyer, or fed out two separate

video streams to an external device, such as a video server.

## To Set Up a Chroma Key

Set up the chroma key with the source you want to use and adjust the parameters. Ensure that the chroma key output has been selected on a keyer so that you can view the output as you adjust the parameters.

1. Click **Navigation Menu > Live Assist > MEs** and select the ME and key that you want to set up.

**Tip:** You can use the same procedure for a MiniME™ or Canvas. You can use the same procedure for a MiniME™.

2. Click **Key Fill** and select the video signal you want to use for the key.
3. Click **Chroma Key** and click **CKX** for the chroma keyer you want to use. Notice that both the **Auto Select** and **Chroma Key** buttons are on. The chroma key uses an auto select key as the key type.

**Tip:** Click **Show Alpha** to have the preview output of the current ME switch to the alpha signal that is being used by the selected keyer. Show alpha is not available for MiniME™ outputs.

**Tip:** Click **Key Preview** to force the program output of the selected keyer to the preview output of the switcher.

**Tip:** You can also select the chroma keyer as a source on the key bus and click **Chroma Key** to navigate to the **Chroma Key Parameters** page. You can also press the user select button assigned to the chroma key or press and hold the **CHR KEY** button and press the corresponding keyer button.

4. Click **CK Params**.



5. Click **CK Source** and select the video source you want to use for the chroma key. As the key type is an auto select key, the **Key Fill** is the chroma keyer and the alpha is replaced with the **CK Source** selection.

**Note:** You can only select a physical input, Media-Store, MediaWipe, or clip player for a chroma key. You can also select an Aux Bus or a bus follow, but the source selected on the Aux Bus or follow must be valid for the chroma key.

6. Click the **Color** button for the color of the background you are using for your chroma key.

7. Click **Init**.

The chroma key engine initializes and attempts to remove the selected background color from the video. Any further adjust is only required if you want to adjust aspects of the key.

8. Click the **Key Type** button for the chroma key mode you want to use.

- **Wedge Key** — Based on the standard chroma keyer and discriminates between the color vector angle and level of the background color vs the color vectors and levels in the foreground components.
- **Detail Key** — Differs from the standard chroma keyer in that it adds luminance dependency to a three-dimensional spherical color discriminator.
- **Combination Key** — Combine the two modes to offer good capture of high luma detail in the edge regions as well as compensation for similar foreground and background levels.

**Note:** All adjustments are always available, even if they are not applied by the selected mode.

**Tip:** Although adjustment can be made to either key type while the combined output is selected, it is recommended that adjustments of either key type be conducted with only that key type selected. This eliminates the possibility of the combined key type hiding or concealing the result of adjustments.

9. Click **Detail Key** and adjust the **Detail Key Parameters** as follows:

**Tip:** The Detail key type is layered over the Wedge key type and has the largest contribution to the final key-edge quality.

- **Clip** — use this setting to clip between the foreground and background. You are looking to achieve complete background removal.

**Tip:** Clip should be set to the point where the background is just removed. Setting it too high will reduce edge quality.

- **Gain** — use this setting to lift the fill image. You are looking to achieve solid fill content.

**Tip:** Setting the gain too high may introduce dark boundaries.

- **Shadow Sensitivity** — use this setting to adjust the level of dark image areas, particularly in cast shadow areas.

- **Shadow Density** — use this setting to adjust the apparent lightness of the dark / shadow areas in conjunction with the **Shadow Sensitivity**.
- **Highlight Sensitivity** — use this setting to fill areas with specular highlights, such as reflective surfaces, that can show through to the background.

10. Click **Wedge Key** and adjust the **Wedge Key Parameters** as follows:

- **Gain** — use this setting to set the **Angle Control** to 100 and the **Lift** to 0 and then adjust this setting until the background is fully removed, leaving a reasonable edge to the key. Too much gain will produce hard and undesirable edges.

*Tip: Adjust the **Gain** with the **Bkgd Luma Suppress** to balance between background removal and edge quality.*

- **Bkgd Luma Suppress** — use this setting to compensate for uneven color or lighting in the shot to ensure the chroma background is fully suppressed.

*Tip: Turn on a box mask in the keyer you are using to view the chroma key output to compare the backgrounds. The masked area shows the background source without the key settings applied.*

- **Angle** — use this setting to change the color wedge angle (wedge shape) that is used to detect areas of foreground (fill) and background (alpha) based on the chosen color vector. This can help fill in areas of heavy spill without hardening edge detail.
- **Lift** — use this setting to amplify the generated alpha signal to fill in areas of transparency.
- **Highlight Correction** — use this setting to lift areas of the image might contain high luminance levels at edge boundaries. This could be due to lighting conditions, camera setup, or subject.

11. Adjust the **Global Parameters** as follows:

- **Chroma Angle** — use this setting to select the fill color that has been detected as color spill. You should not have to adjust this setting.
- **Edge Luma** — use this setting to offset the detected level of the chroma background and allow for fine tuning.

*Tip: Click **Auto Edge Luma** to have the switcher automatically adjust the edge luminance.*

*Tip: If the subject image contains fine detail such as fine hair with a luminance level that is close in value to the chroma set color background level – it may be difficult to provide good separation between background and foreground elements.*

- **Edge Softness** — use this setting to filter the edges to eliminate undesirable hard edges and add realism to a scene by simulating depth of field characteristics.
- **Re-Spill** — use the **Re-Spill Color** and **Re-Spill Sat** settings to select a color that is near the average color of the background/lighting that needs to be added into those areas of the fill that contain the spill from the chroma set.

*Tip: Click **Auto Re-Spill Color** to have the switcher automatically adjust the re-spill colors based on the **Measurement Src** selection.*

12. Use the automatic adjustments as follows:

*Tip: The **Auto Adjust** allows you to have the chroma keyer continuously measure the replacement background, the background you are keying the subject onto, used in the final composite.*

- Click **Measurement Src** and select the video source that you want to place the chroma key over. This source is used for the automatic adjustment of the chroma key.
- Click **Auto Edge Luma** to have the edge luminance automatically adjusted, based on the replacement background.
- Click **Auto Re-Spill Color** to have the re-spill color automatically adjusted, based on the replacement background.

### To Box Mask a Key

Box masks can be adjusted for size, location, rotation, and multiplication.

1. Click **Navigation Menu > Live Assist > MEs** and select the ME and key that you want to set up.

*Tip: You can use the same procedure for a MiniME™ or Canvas. You can use the same procedure for a MiniME™.*

2. Click **Mask > Box**.



3. Click **Mask Force** to force the area inside the mask region to the foreground.

4. Click **Mask Invert** to invert the masked area with the unmasked area.
5. Set up the mask as required.
  - **Size** — adjust the size of the mask region.
  - **Left Edge** — adjust the position of the left edge of the mask region.
  - **Right Edge** — adjust the position of the right edge of the mask region.
  - **Top Edge** — adjust the position of the top edge of the mask region.
  - **Bottom Edge** — adjust the position of the bottom edge of the mask region.
  - **X-Position** — position the mask on the x-axis. This adjust both the left and right edges at the same time.
  - **Y-Position** — position the mask on the y-axis. This adjusts both the top and bottom edges at the same time.
  - **Edge Softness** — apply softness to the edges of the mask region.

*Tip: You can use the Positioner to adjust the size and position of the box mask.*

## UltraChrome Best Practices

High-quality chroma keying with a natural look is fully-achievable with the UltraChrome 2 keying system. However, as with any chroma key system, careful attention should be paid to the chroma key environment.

Keep the following in mind when working with a chroma key:

- The set should be evenly-lit, with a reasonable level of brightness, too bright or too dark will compromise the ability to produce a great result. High brightness generates high levels of reflected color background (Spill) into the foreground subject. When the camera output is viewed on a waveform monitor, the background set level should read between 50-75% of the overall image level. The foreground subject(s) should be separately lit.
- Adjust camera shading using appropriate charts, ensuring that grey scale, lens flare, gamma, and white/black balance correctly set. If using the AC-H200-UCHR camera, it is recommended it be set in HDR mode - HLG1200. This mode is compatible with standard (non-HDR) signals and the wider dynamic range allows greater image separation in lower-light regions. Also, the

camera should be set at its minimum gain to ensure the lowest noise levels, and detail levels should be kept at minimum to avoid sharp edge transitions.

- Real elements, presenters, and props should not contain colors similar to the background. Clothing or props with high reflectivity should also be avoided to minimize color spill (colored light reflected from set onto foreground subject).

## Masking

The switcher has a mask available for every key channel (including chroma keys), plus an additional mask available to each chroma key channel. Chroma keys can use static box masks or dynamic masks from an external source. Dynamic masks are fed from virtual set systems (such as Ross Voyager) and follow camera moves through camera-tracking data provided by robotic systems.

From the **Physical Input Configuration** tab (Click **Navigation Menu** > **Configuration** > **Inputs** > **External**), click the **Mask Source** button for the input that has the chroma key source on it and select the input source that has the mask you want to apply.

## The Four Chroma Key Commandments

1. **A Great Chroma Key is Made from a Great Original Source** — Before attempting to set up the chroma keyer, make sure lighting, background, and talent all look great on the camera; and that camera Gain and Detail have been reduced to a necessary minimum.
2. **No Chroma Key is Ever the Same, Start Fresh with Init** — Every set has its own lighting conditions, camera and lens setups, CK wall-quality, consistency of paint, foreground talent clothing, colors, and skin tones. The UltraChrome automatic initialization (**Init**) does not require color pickers or hue controls; once the general color vector has been selected, it will analyze the entire frame and determine the exact chroma vector and angle of the color background to be removed.
3. **Init, Try, Re-Init and Try Again** — The fine-tuning required to get a great result is often minimal and frequently hinges on the adjustment of a single parameter. Changing the value of the wrong parameter can make it impossible to then make corrections with



---

other controls. When learning the nuances of this chroma key, re-**Init** after making a change that does not achieve the desired result and then try another. Also, all chroma key parameters are saved in the memory system, so you can save a setup and then start over if necessary.

- 4. No Last Minute Changes** — Once the chroma set, lighting, and cameras are tuned for best performance - don't change anything! On a normal set, it is common to make last minute tweaks and changes to lighting, iris settings, and even talent/wardrobe. When chroma keying, these changes will require the key to be reset and adjusted - which is fine if you have the time. Avoid change if you can, especially at the last minute, it can substantially lower operator blood pressure.

## Chroma Key Tips and Tricks

Some useful tips for how to get your production ready for a flawless chroma key, and some tricks for how to deal with difficult shadows.

### The Set

In every set design, care must be taken to ensure there are no visible seams, joints or hard corners that will appear on camera. Paint should be chosen that is as close as possible to the exact color vector that will be used, typically Green or Blue. If the paint pigment is not precise and several batches of paint or repaint are required, the uneven color result will make the perfect key impossible. There are several vendors of chroma key specific paints and set materials you can work with. Ross Video works closely with ProCyc ([www.procyc.com](http://www.procyc.com)) in the USA, we whole-heartedly recommend their products.

The set should be sized to allow ample separation between foreground talent and the chroma background wall; ideally at least 6-to-8 feet of separation. The further the distance, the easier it is to reduce unwanted color spill and achieve good lighting separation.

### Lighting

Lighting configuration will naturally vary with set design and choice of lighting equipment, but there are some simple rules that will help achieve the best results:

- Light the chroma set independent of the talent: light the walls and floor to achieve flat, even illumination.
- Light the talent independently: use back and side lighting to minimize color spill from the walls and floor. Use floor or stand mounted front fill lights to eliminate areas of spill reflected from the floor.
- Don't light the background too brightly: it should ideally be half a stop or more below the level of the foreground subject (about 50 - 75% of the foreground on a waveform monitor).
- Don't rely on eyesight: when assessing the set lighting and background quality and finish - eyesight will mislead you. Look at the camera output on a waveform/vectorscope and ensure that the chroma background reads as an even signal without variation.

## Camera and Lenses

**Resolution:** Cameras naturally vary in performance; the ideal camera has a high-resolution imager with very low noise. This is critical for an excellent final result. Medium resolution imagers can produce great results in normal video productions, but rely on relatively high-detail settings to enhance image edges. Detail-enhanced edges are undesirable in chroma keying. These edges will appear as bright or dark key halos, which cannot be removed without compromising overall key quality.

**Imager/Sensor Noise:** Noise is always present in the video image but can be minimized by choice of sensor type and gain settings. Image noise has a significant effect on chroma keying as the chroma levels in a normal video image are much lower than the luma levels - as a result, the chroma information contains proportionately more noise. High noise-levels will be most obvious in dark areas of a developed chroma key and can be very difficult to remove without compromising key quality. The better the noise performance of the camera - the better the end result.

**Lens:** Select a camera lens based on the set size and production needs. Some lower-cost lenses can exhibit chromatic aberration - colored halos - around edge transitions in certain lens regions. This has a highly undesirable effect on edge quality.

**Detail:** Avoid high levels of detail regardless of camera type; if detail is necessary to achieve the image quality desired, then the best choice is to use the chroma key Edge Softness control to soften the edge and conceal the aberrations caused by detail setting.

### Shadow Tricks

Developing a shadow from the chroma key set can give you a more realistic final output, but this is very difficult to do. As previously mentioned, noise lurks in the shadows and can look quite nasty. But all is not lost, very acceptable shadows are achievable with a nifty keying trick.

1. Setup the chroma key as usual; don't worry about resolving the shadow, just make the best key you can. Assign the key to an ME or MiniME™ keyer, with an empty keyer below it (Example: chroma key on Key 2, with Key 1 unassigned).

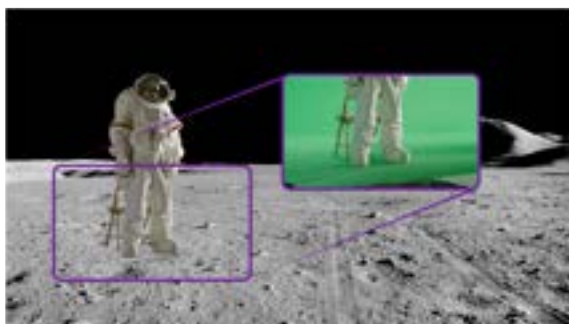

**Tip:** No attempt is made to resolve any shadows as they are weak and indistinct. Raising the shadow sensitivity would bring up other set errors.

2. Set Key 1 type as Auto Select then select Black as the Key Fill and the chroma key source camera (in this example: Media Store 1) as the Key Alpha source. Turn on Key Invert and leave the keyer in Normal Mode.
3. Now adjust the key Clip and Gain until the shadow area has the look you desire (you can ignore the rest of the image as it will be concealed by the chroma key above it).



4. Now adjust Key Transparency for the most realistic shadow look.



5. Turn on the chroma key in Key 2 - Voila! Great looking shadow from a poor image. Good trick!

### DVE Keys

The DVE key allows you to apply digital video effects, such as scale, crop, aspect ratio, position, and border to a video image or another key type. When the DVE is applied to another key type, it is said to be flying (Fly Key).

**Tip:** You can see where DVE channels are allocated from the **Status** page in DashBoard.

#### Keep the following in mind:

Keep the following in mind when working with a Fly Key:

- The Fly Key feature consumes a single DVE channel for self keys, but two DVE channels for an auto select and chroma keys.
- The Fly Key feature cannot be applied to a DVE key.
- The Key Invert feature is not available for a Fly Key.
- The self key Fly Key can be used with all Canvas layouts. The auto select key Fly Key can only be used with the Dual Vert or Dual Horiz Canvas layouts.

- A chroma key should be initialized and adjusted before the DVE (Fly Key) is applied to it.
- A DVE key will unfreeze when it is copied or swapped.
- 3D border and lighting are not available when the switcher is operating in SD 4 Key mode.

## To Set Up a DVE Key

The DVE engine allows you to apply digital video effects, such as scale, crop, aspect ratio, position, and border to a video image in 2D space.

The DVE resources for this key may not be available. Depending on how your switcher is configured, you may be asked to steal the resources from another element, or be prevented from using the resources.

**Note:** The DVE Freeze feature is only available in SD or HD video modes.

1. Click **Navigation Menu > Live Assist > MEs** and select the ME and key that you want to set up.

**Tip:** You can use the same procedure for a MiniME™ or Canvas. You can use the same procedure for a MiniME™.

2. Click **Key Fill** and select the video signal you want to use for the key.
3. Click **DVE > Position / Crop**.

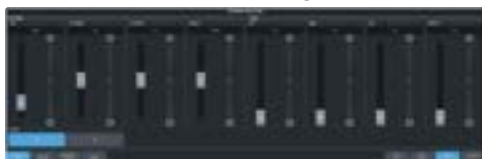

**Tip:** Click **Show Alpha** to have the preview output of the current ME switch to the alpha signal that is being used by the selected keyer. Show alpha is not available for MiniME™ outputs.

**Tip:** Click **Key Preview** to force the program output of the selected keyer to the preview output of the switcher.

4. Use the **X-Position**, **Y-Position**, and **Size** sliders in the **Positioning** area to position and size the key.
5. Use the **Aspect** slider to adjust the aspect ratio of the key.
6. Use the **Left** and **Right** sliders to crop the left and right sides of the key.
7. Use the **Top** and **Bottom** sliders to crop the upper and lower sides of the key.

8. Click a **Freeze** button (SD or HD only) to freeze the video and appearance of the key (**On**). When a key is frozen, the DVE attributes are disabled and you can not move the key.
9. Click **Mask** to apply a mask to the key.

Refer to the section [To Apply a Border/Edge Softness to a DVE Key](#) on page 44 for information on applying a border to the key.

## To Apply a DVE to a Key (Fly Key)

The Fly key is when the DVE engine is applied to another key type.

The DVE resources for this key may not be available. Depending on how your switcher is configured, you may be asked to steal the resources from another element, or be prevented from using the resources.

You should set up your key as you want it before applying the Fly Key.

1. Click **Navigation Menu > Live Assist > MEs** and select the ME and key that you want to set up.
2. Click **DVE** and click **On**.



3. Use the **X-Position**, **Y-Position**, and **Size** sliders in the **Positioning** area to position and size the key.
4. Use the **Aspect** slider to adjust the aspect ratio of the key.
5. Use the **Size** and **Softness** sliders in the **Edge Softness** area to apply softness to the edges of to the key.

Refer to the section [To Apply a Border/Edge Softness to a DVE Key](#) on page 44 for information.

6. Use the **Left** and **Right** sliders to crop the left and right sides of the key.
7. Use the **Top** and **Bottom** sliders to crop the upper and lower sides of the key.
8. Click a **Freeze** button (SD or HD only) to freeze the video and appearance of the key (**On**). When a key is frozen, the DVE attributes are disabled and you can not move the key.

## To Apply a Border/Edge Softness to a DVE Key

A DVE border or edge softness is applied to the edges of the DVE key and is manipulated as part of the key.

**Note:** You can only apply a border to a DVE key. Fly Keys, such as chroma keys or auto select keys with DVE applied to them cannot have a border applied to them. Instead, the selection is Edge Softness and is used to soften the edges of the key without any color.

1. Click **Navigation Menu > Live Assist > MEs** and select the ME and key that you want to set up.

**Tip:** You can use the same procedure for a MiniME™ or Canvas. You can use the same procedure for a MiniME™.

2. Click **DVE > Border**.

**Note:** The 3D borders are not available when the switcher is operating in the SD 4 Key mode.



3. In the **Border** area, click **On** to apply the border to the key or **Off** to have it not visible. The border settings are not changed when the border is turned off.

**Tip:** To seamlessly apply a border with a custom control or memory, recall the border settings with the border turned off and then turn the border on with another CC event or memory. Remember to insert a pause between the border settings and turning the border on to allow for the border settings to be applied.

4. In the **Border Type** area, select the type of border you want to apply.
  - **Flat** — border with no bevel appearance on the outside or inside of the border.

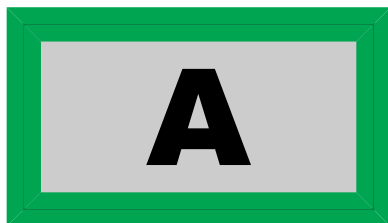

- **Bevel Flat** — border that appears bevelled on the outside and flat on the inside.

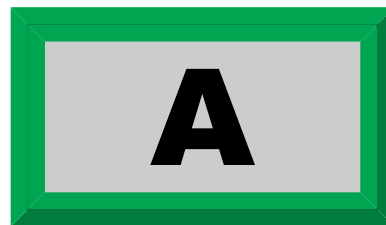

- **Flat Bevel** — border that appears flat on the outside and bevelled on the inside.

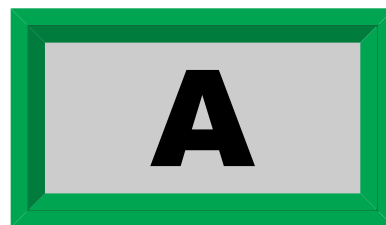

- **Bevel Bevel** — border that appears bevelled on both the outside and inside.

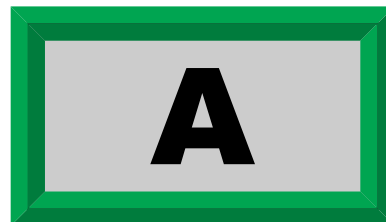

5. Use the **Size** slider to adjust the size of the border.
6. Use the **Perspective** slider to adjust the viewing angle of the border. This gives the key the appearance of being rotated in 3D space. Use **Border Lighting** to further enhance this look.

**Tip:** Perspective is applied to the border of the key and not to the video inside the key. This can result in a black bar on the side of the key video. Apply a larger border or manually crop the key to remove the bar. Use **Perspective Auto Crop** to automatically crop the key when perspective is applied.

7. Select a default or custom color for the border (borders only). The inner and outer border use the same color.
  - **Default** — click one of the preset colors.
  - **Custom** — click the arrow to the right of the **Border Color** area and use the **Hue**, **Saturation**, and **Lightness** sliders to select your own color. Click **OK** to apply the color or **Live** to apply it in real-time.
8. Use the **Transparency** slider to adjust the transparency of the inner and outer border.
9. Use the **Interior Softness** and **Exterior Softness** sliders to adjust the softness of the inner and outer border.

- **Interior Softness** — adjust the softness of the interior edge of the inner border.
  - **Exterior Softness** — adjust the softness of the exterior edge of the outer border.
10. Use the **Bevel Position** slider to adjust the transition point of the inner and outer border. This is the point where the inner and outer border meet.
  11. Use the **Overhang** slider to adjust the position of the border relative to the edges of the key.

*Tip: At 50 the middle of the border is at the edge of the key. As you increase the overhang the border moves further to the outside of the key, revealing more of the video in the key.*

12. Use the **Middle Gain** and **Corner Gain** to adjust the brightness of the corners or center of the bevelled border (does not apply to flat border).
  - **Middle Gain** — adjust the brightness of the center portions of the border. These are the sections of the border that are not in the corners.
  - **Corner Gain** — adjust the brightness of the corners of the border.

### To Apply Lighting to the DVE Border

Apply a drop shadow and lighting effect to the DVE Key and border.

1. Click **Navigation Menu > Live Assist > MEs** and select the ME and key that you want to set up.

*Tip: You can use the same procedure for a MiniME™ or Canvas. You can use the same procedure for a MiniME™.*

2. Click **DVE > Shadow / Lighting**

*Note: The 3D borders/lighting are not available when the switcher is operating in the SD 4 Key mode.*



3. Click a **Drop Shadow** button to turn the shadow on (**On**) or off (**Off**).  
The drop shadow is semi-transparent and appears behind the key on top of the background. The position of the shadow is adjusted using the border lighting settings.

Effects that are applied to the exterior border are also shown on the drop shadow.

4. Use the **Shadow Transparency** slider to adjust the amount of the background that is visible through the drop shadow.
5. Use the **Shadow Softness** slider to adjust the sharpness of the edges of the drop shadow.
6. Use the **Shadow Depth** slider to adjust the apparent distance of the shadow from the key.
7. Use the **Brightness** slider to adjust the brightness of the light.
8. Use the **Horizontal Lighting** and **Vertical Lighting** slider to adjust the position of the lighting.

*Tip: As you change the position of the light, the brightness of the bevel on the inner and outer border changes to match the shadow created by the light.*

## Show Alpha

You to route the processed alpha for the selected keyer to the preview output for the ME you are working on.

Show alpha is not available on a MiniME™ or Canvas.

- Select the keyer that you want to show the alpha for and press and hold the **SHOW ALPHA** button on the control panel. The preview output of the ME shows the processed alpha of the selected key until the button is released.
- Select the keyer that you want to show the alpha for and double-press the **SHOW ALPHA** button. The preview output of the ME shows the processed alpha of the selected key until the button is pressed again.
- Toggle the **Show Alpha** button on from the Live Assist.

## Masks

A Mask is a technique in which a pattern is combined with the key source to block out unwanted portions of the key source.

Two types of masks are available, Box masks and Pattern masks. All key types can be masked.

- **Box Mask** — uses a simple box shape to mask out a portion of the key

- **Pattern Mask** — uses a pattern from the pattern generator to mask out a portion of the key

**Note:** Pattern masks are not supported in UHDTV1.

### To Pattern Mask a Key (SD or HD Only)

Pattern masks can be adjusted for size, location, rotation, and multiplication.

1. Click **Navigation Menu > Live Assist > MEs** and select the ME and key that you want to set up.

**Tip:** You can use the same procedure for a MiniME™ or Canvas. You can use the same procedure for a MiniME™.

2. Click **Mask > Pattern**.



3. Select the pattern you want to use for the mask.
4. Click **Mask Force** to force the area inside the mask region to the foreground.
5. Click **Mask Invert** to invert the masked area with the unmasked area.
6. Set up the mask pattern as required.
  - **Size** — adjust the size of the mask region.
  - **Softness** — apply softness to the edges of the mask region.
  - **Border Size** — apply a border to the mask region and adjust the size. At size 0 the border is off.
  - **Aspect** — adjust the aspect ratio of the mask. Not all patterns allow you to adjust the aspect.
  - **Rotation** — rotate the mask pattern. Not all patterns can be rotated
  - **H-Multiply** — multiply the mask pattern horizontally.
  - **V-Multiply** — multiply the mask pattern vertically.
  - **X-Position** — position the mask on the x-axis.
  - **Y-Position** — position the mask on the y-axis.

### To Box Mask a Key

Box masks can be adjusted for size, location, rotation, and multiplication.

1. Click **Navigation Menu > Live Assist > MEs** and select the ME and key that you want to set up.

**Tip:** You can use the same procedure for a MiniME™ or Canvas. You can use the same procedure for a MiniME™.

2. Click **Mask > Box**.



3. Click **Mask Force** to force the area inside the mask region to the foreground.
4. Click **Mask Invert** to invert the masked area with the unmasked area.
5. Set up the mask as required.
  - **Size** — adjust the size of the mask region.
  - **Left Edge** — adjust the position of the left edge of the mask region.
  - **Right Edge** — adjust the position of the right edge of the mask region.
  - **Top Edge** — adjust the position of the top edge of the mask region.
  - **Bottom Edge** — adjust the position of the bottom edge of the mask region.
  - **X-Position** — position the mask on the x-axis. This adjust both the left and right edges at the same time.
  - **Y-Position** — position the mask on the y-axis. This adjusts both the top and bottom edges at the same time.
  - **Edge Softness** — apply softness to the edges of the mask region.

**Tip:** You can use the Positioner to adjust the size and position of the box mask.

## Split Keys

A Split key allows you to assign a different alpha source for a key than the fill/alpha associations that are set up during configuration, or to use a separate alpha source for a Self key.

A split key can be applied to an auto select, or self key.

### To Set Up a Split Key

A split key works on an **Auto Select** or **Self Key** that has been set up and you want to apply a different alpha to.

- 
1. Set up your key with the video source you want to use.
  2. Click **Navigation Menu** > **Live Assist** and select the key you want split.

*Tip: From the control panel, press and hold the **SELF** or **AUTO** (depending on the type of key you are splitting) and press the source button for the new alpha you want to use.*

3. Click **Key Alpha** and select the new alpha you want to use.

# Memory Functions

A memory register is a snapshot of the current state of the switcher that can include one or multiple ME, MiniME™, Canvas, scenes, or chroma key outputs. Up to 100 memory registers per ME, MiniME™, Canvas, scene, or chroma key can be stored and recalled on the switcher. Each of these memory registers can store as little as the information of one ME, or as much as the current state of the entire switcher, including all ME, MiniME™, Canvas, scenes, chroma key outputs, Aux Buses, and DVE settings.

## Storing Memories

When you store a memory, you are storing the complete state of that panel row. This includes the current state of all the areas on the ME, including keyer settings, transition rates, wipe and pattern selections, and source selections. In addition to the current state of the panel, the current settings for the various keyers, such as chroma key settings, and clip and gain settings, are also stored.

### To Store a Memory

How to store a memory.

1. Click **Navigation Menu > Live Assist > Memory > Store > General.**



2. In the **Inclusions** area, select the ME, MiniME™, Canvas, UltraScene, and chroma keys that you want to store the memory for. When you include an area in a memory, the current state of that area is stored in the memory and will be recalled with the memory.

*Tip: You can deselect all inclusions for a memory so that it doesn't affect these areas. This can be used to create a memory that only recalls Media-Store or Aux bus selections.*

3. In the **Memory Store** area, click the **Bank X** and **X:Mem** button for the bank and memory register that you want to store to.

*Tip: If a memory register contains a memory for the area(s) selected in the **Inclusions**, the button glows purple and the areas that the register contains a memory for are listed*

*below the memory number. The currently selected memory register glows blue.*

4. Select the recall mode for the memory. This is the mode that is stored in the memory, but can be overridden when the memory is recalled.
  - **Program** — all elements are recalled as stored (default).
  - **MemoryAI** — current on-air elements are unchanged and the transition area is configured to take the on-air elements of the memory on-air with the next transition.
  - **Effects Dissolve** — on-air elements listed below are transitioned to the elements stored in the memory. The time it takes to go from the current elements to the elements in the memory is set in the **Effects Duration** field.
    - Matte colors (background, wash or borders)
    - Keyer settings like clip, gain, transparency
    - Mask position and size
    - Chroma key settings, except the background color
    - Pattern settings like size, position, aspect, border, softness, rotation
    - DVE settings like size, position, aspect, border, softness, cropping
    - Media-Store x/y position
    - Transition Progress
5. Set the memory attributes that you want recalled with the memory. Refer to [Memory Attributes](#) on page 50 for information on memory attributes.

*Tip: All attributes are stored in the memory. Turning individual attributes on or off sets whether that item is included with the memory recall. Individual attributes can be turned on or off when the memory is recalled.*

6. Click **Store** to store the memory.

## Recalling Memories

When you recall a memory, the existing configuration of that ME is replaced with the settings stored in the memory.



## Keep the following in mind:

Keep the following in mind when recalling memories:



- How a memory is recalled depends on the how the Memory Attributes are set.
- Recalling a memory that includes a new Media-Store image to be loaded from a USB drive may result in the currently loaded image to be displayed for a few frames while the new image is loaded.
- Recalling a memory that includes a source assigned to a camera also recalls the shot stored in the memory for that camera if the **CamRcl** memory attribute is set to **Recall**. There is no delay in the memory recall so camera movement may be visible while the shot is recalled.
- You can override the video source stored in a memory by pressing and holding a source button and recalling the memory (Bus Hold). The held source button overrides the source that is recalled with the memory for that bus. The memory is not affected by a Bus Hold and will recall properly without the Bus Hold.
- Enabling Memory AI mode changes the way key elements are recalled. If a key is currently on-air, the element for that key is recalled in the next available off-air key. If there is no available off-air keys, the element is not recalled.
- If **Disable Audio Memories** is set to **On** (Click **Navigation Menu > Configuration > System > Global**) the audio memory attributes are disabled.

## Related information

[Memory Attributes](#) on page 50

## Memory Attribute Color Coding

For a memory recall you can set individual attributes to be recalled or not, regardless of how they were stored. How the attribute is recalled is indicated by the color of the attribute button.

Color	Description
	<b>As Stored</b> — the memory attribute is recalled exactly as it was stored in the memory.
	<b>Recall</b> — the memory attribute is recalled with the memory, even if the attribute was not set to be stored with the memory.

Color	Description
	<b>No Recall</b> — the memory attribute is not recalled with the memory, even if the attribute was set to be stored with the memory.

## To Recall a Memory

How to recall a memory using Dashboard.

1. Click **Navigation Menu > Live Assist > Memory > Recall > General**.



2. In the **Inclusions** area, select the ME, MiniME™, Canvas, UltraScene, and chroma keys that you want to recall the memory for.

*Tip: You can deselect all inclusions for a memory so that it doesn't affect these areas. This can be used to create a memory that only recalls Media-Store or Aux bus selections.*

3. In the **Memory Recall** area, click the **Bank X** button for the bank that you want to recall from.

 **Important:** Clicking a **X:Mem** button recalls that memory.

*Tip: If a memory register contains a memory for the area(s) selected in the **Inclusions**, the button glows purple and the areas that the register contains a memory for are listed below the memory number.*

4. Select the recall mode for the memory.

*Note: Recall attributes are color-coded for how they are going to be recalled. Refer to [Memory Attribute Color Coding](#) on page 49 for information on the color meaning.*

- **As Stored** — recall the memory with the same attributes that it was stored with.
- **Program** — all elements are recalled as stored (default).
- **MemoryAI** — current on-air elements are unchanged and the transition area is configured to take the on-air elements of the memory on-air with the next transition.
- **Effects Dissolve** — recall the memory with an effects dissolve to the new memory elements. The time it takes to go from the current elements to the elements in the memory is set in the

### Effects Duration field or using the **Effect Duration From Memory**.

5. Set the memory attributes that you want recalled with the memory. Refer to [Memory Attributes](#) on page 50 for information on memory attributes.

**Note:** All attributes are stored in the memory. Turning individual attributes on or off sets whether that item is included with the memory recall. Individual attributes can be turned on or off when the memory is recalled.

6. Click the **X:Mem** button to recall the memory.

**Tip:** Click **Undo** to undo the last memory recall.

## Memory Attributes

Memory Attributes allow you to specify what elements are recalled with a memory, as well as adding effects to memory recalls. These elements include the background/preset buses, keyer bus, Aux bus, and Media-Store selections, as well as keyer on-air status, and transition selections.

In addition to setting which sources to recall with the memory, effects such as performing an auto transition after the memory recall or running a custom control after the memory recall, can also be included.

Memory attributes can be set both when the memory is stored, and when it is recalled. This allows you to store a set of attributes with a memory and then recall it as stored, or override the attributes stored in the memory and apply different ones when the memory is recalled. A memory attribute does not need to be stored in the memory to be recalled.

**Tip:** It is recommended that if you are new to working with memories, use the memory store attributes to set how you want a memory to be recalled and set the recall attributes to be **Memory**.

### To Set the Memory Attributes

Memory attributes can be set when the memory is stored or when it is recalled. This procedure sets the store attributes, but the information applies to both.

1. Click **Navigation Menu > Live Assist > Memory > Store**.
2. Click **General** and set the attributes as required.



**Note:** For information on the recall mode (**Program/MemoryAI/Effects Dissolve**) refer to [To Store a Memory](#) on page 48.

- **Roll Clip** — set whether a play command is triggered when a source that is assigned to a video server is recalled.
- **Camera** — set whether camera shots are recalled.
- **Override Chroma Key X Inclusion** — set whether the chroma key source and settings for the selected channel are recalled.
- **MediaX** — set whether Media-Store items and settings for the selected channel are recalled.

3. Click **ME X**. The attributes for each ME are separate and must be set for each ME you want to include in the memory.



- **Trans Area** — set how the next transition type and parameters are recalled.
- **Next Trans** — set how the next transition area is recalled.
- **Run Auto** — set whether a transition is performed after the memory is recalled. (Not available during Effects Dissolve transitions.)
- **PGM Bus** — set how the sources selected on the program bus are recalled.
- **PST Bus** — set how the sources selected on the preset bus are recalled.
- **Shared Pattern** — set whether the settings for the shared Key Mask/Wash pattern generator is recalled.
- **Key X Bus** — set whether the source selected on the key bus is recalled.
- **Key X Active** — set whether the on-air status of the key is recalled.
- **Key X Type** — set whether the key type is recalled.
- **Key X Mask** — set whether mask settings for the key are recalled.

4. Click **Scene**.



- **Layer X Bus** — set how the source (video and alpha) selected on the layer is recalled.
- **Layer X Active** — set how the on-air or off-air status of the layer is recalled.
- **Layer X Type** — set how the layer key type is recalled.

5. Click **MiniME 1-4**.

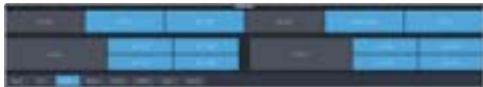

- **Trans Area** — set how the next transition type and parameters are recalled.
- **Next Trans** — set how the next transition area is recalled.
- **Run Auto** — set whether a transition is performed after the memory is recalled. (Not available during Effects Dissolve transitions.)
- **PGM Bus** — set how the sources selected on the program bus are recalled.
- **PST Bus** — set how the sources selected on the preset bus are recalled.
- **Key X Bus** — set whether the source selected on the key bus is recalled.
- **Key X Active** — set whether the on-air status of the key is recalled.
- **Key X Type** — set whether the key type is recalled.
- **Key X Mask** — set whether mask settings for the key are recalled.

6. Click **Canvases**.

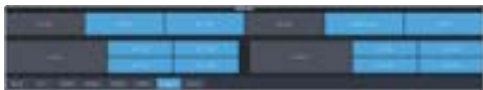

- **Trans Area** — set how the next transition type and parameters are recalled.
- **Next Trans** — set how the next transition area is recalled.
- **Run Auto** — set whether a transition is performed after the memory is recalled. (Not available during Effects Dissolve transitions.)
- **PGM Bus** — set how the sources selected on the program bus are recalled.
- **PST Bus** — set how the sources selected on the preset bus are recalled.

- **Key X Bus** — set whether the source selected on the key bus is recalled.
- **Key X Active** — set whether the on-air status of the key is recalled.
- **Key X Type** — set whether the key type is recalled.
- **Key X Mask** — set whether mask settings for the key are recalled.

7. Click **Chroma Key**.



- **Source** — set whether the source selected on the chroma key bus is recalled.
- **Parameters** — set whether chroma key settings are recalled.

8. Click **Auxes**.



- **Aux X** — set whether the source selected on the aux bus is recalled.

9. Click **Audio**.

**Note:** If **Disable Audio Memories** is set to **On** (Click **Navigation Menu > Configuration > System > Global**) the audio memory attributes are disabled.

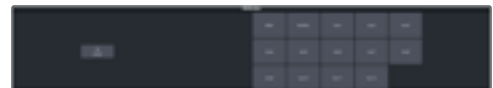

- **Main** — set whether the configuration of the main audio mix is recalled.
- **Monitor** — set whether the configuration of the monitor audio mix is recalled.
- **Aux X** — set whether the configuration of the aux audio mix is recalled.

## Deleting a Memory

You can delete the contents of a single memory. Only one memory can be cleared at a time, and you cannot undo the deletion.

**Tip:** You can clear all memories from the switcher from the control panel. (Press **MENU > Reset > NEXT > NEXT.**)

### To Delete a Memory

Delete an individual memory or bank.

1. Click **Navigation Menu > Live Assist > Memory > Store**

2. In the **Memory Store** area, click the **Bank X** and **Mem X** button for the memory register that you want to delete.
3. Click **Delete Memory**.

## Memory Names and Mnemonics (TouchDrive only)

Assign custom mnemonic colors and names to individual memories. These are only visible on the TouchDrive panel when the user select bus is assigned to a memory bank,

### To Assign a Name to a Memory

Memories can have custom names and colors on the TouchDrive control panel.

1. Click **Navigation Menu > Live Assist > Memory > Memory Mnemonics**.



2. Click **Bank X** to select the bank that the memory you want to name is on.
3. Click the memory you want to name.

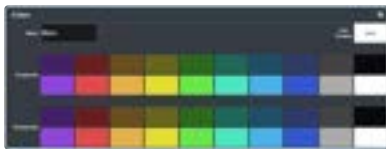

Setting	Description
<b>Name</b>	Enter a new name for the selected memory.
<b>Foreground</b>	Click a <b>Foreground</b> button to select the color you want to apply to the text on the mnemonic.
<b>Background</b>	Click a <b>Background</b> button to select the color you want to apply to the background on the mnemonic.

## Audio Mixer

The audio mixer node in DashBoard provides a graphical interface to all the audio sources and mixer layers. An audio channel must be routed to the switcher to be controllable by the audio mixer interface. Audio sources can come from the embedded audio on an input BNC, through the 1RU Audio Breakout Module, or from the Media-Store.

**Note:** The RAVE Audio Mixer option (CUF-RAVE-AUDIO) must be installed to use the audio mixer.

**Note:** The audio mixer interface is only available in DashBoard.

## Sample Rate Conversion

Integrated sample rate converters can convert audio sample rates of up to 192kHz on the AES Input port (2 channels) on the 1RU Audio Breakout Module as well as the input BNCs (16 channels).

The sample rate converters will convert the audio to the video reference rate.

**Note:** The switcher must be in an SRC mode for sample rate conversion to be available.

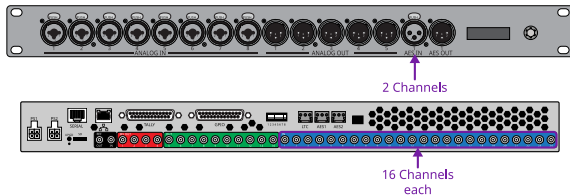

## Audio Mixer Interface

The audio mixer interface allows you to control the mix levels for all the incoming channels to a mix layer, as well as the main level for the output of that layer. The **Main** layer also has a monitor output and level.



1. **Audio Channel Strips** — Each strip controls the input from that audio channel. Strips are color coded for where the audio comes from. The controls available on each strip depend on how the audio fader is configured.

- **Bal/Pan:** — adjust the balance or pan of the audio source. Whether Balance or Pan is applied to the audio source is determined automatically based on the audio source assigned to the fader.
- **Balance** — the volume of the left and right stereo channel. For example, as you move the slider to the right the volume of the right channel is increased and the volume of the left channel is decreased.
- **Pan** — the amount of the left or right input channel that is part of each channel before the mixer. For example, as you move the slider to the right you get more of the left channel in the right channel and the volume of the left channel decreases.
- **Tone** — plays out a tone on the channel. This can help identify that a channel is being routed correctly in the mixer. The frequency of the test tone is set from the **Audio Mixer Configuration** page.

**Tip:** Shortcut buttons are also provided on the **Balance** window for **NG/Ducking**, **EQ**, **Compression Limiter**, and **Config**. These buttons jump directly to the corresponding setup pages for the channel you are on.

- **Mute** — turn off the audio from this source. This does not change the level.
- **Pre/Post (Aux only)** — select whether the audio source on an **Aux** layer is taken before the fader (**Pre**) or after (**Post**) the source fader. If an audio source is taken before the fader, the source fader has no impact on the level of the audio going out the aux layer.
- **Fader** — adjust the level of the audio from the source. You can either move the fader manually or enter a value in the text field at the bottom of the slider.

**Tip:** At the top of the fader are three **Clip** indicators to warn you if clipping is occurring in the Equalizer stage (**EQ**), Compressor/Limiter stage (**CL**), or Noise Gate (**NG**).

- **AFV (Main only)** — turn Audio Follow Video (AFV) on or off for this audio source. AFV is only available for audio that is associated with a video source, such as embedded audio on input BNCs and from the Media-Store. When AFV is on, the audio level is taken to the **AFV Set** level when the associated video source is taken on-air. The audio level is taken

to **-infinity** when the video source is taken off-air.

- **AFV Set** (Main only) — the maximum level that you want the audio to rise to when the associated video source is taken on-air. To set the AFV level, move the slider to the level you want the audio to be at and click **AFV Set**. The **AFV Set** button turns on when the slider is at the AFV set level.
- **PFL** — turn Pre Fader Listen (PFL) on or off for this audio source. This is similar to solo in that it mutes all other sources, but only affects the Monitor (headphone) output. The Main output is not affected by PFL. When **PFL** is turned on for a source a warning light flashes red on the monitor strip.
- **Solo** — mute all other audio sources but the one(s) you turn solo on for. This allows you to quickly isolate a source without having to mute all the other sources. When **Solo** is turned on for a source a warning light flashes red on the main strip.

**Tip:** You can move a fader at any time to bring up an audio source even if the associated audio source is not on-air. This audio source will remain at the selected level until it is brought down again manually or is included in a transition with **AFV** turned on.

2. **Main Level Controls** — The Main and Monitor strips control the levels of the output audio for the mixer. If you select an Aux output this strip changes to control the level for that output.
  - **Effects** — click the **Compressor Limiter** button to jump directly to the corresponding setup pages for the effect you are applying to the output.
  - **Monitor Source** (Monitor only) — select the audio source for the monitor output.
  - **Fader** — adjust the level of the audio output. You can either move the fader manually or enter a value in the text field at the bottom of the slider.
  - **PFL/Solo Clear** (Monitor only) — turn solo off for all sources on this audio layer.
3. **Layer Controls** — select the audio layer that you want to control. Each layer is assigned to an audio output.
4. **Configuration** — open the audio mixer configuration page.

5. **Effects** — open the effects page where you can apply a noise gate, equalizer, and compressor to the audio.
6. **Included Channels** — select whether only the audio sources that have been assigned to each layer are shown (**Custom**), or whether all audio sources are shown (**All**).

## Audio Mixer Setup

The audio mixer has up to 13 mixer layers that can be configured for which inputs are available to them and which physical outputs they are routed to.

The audio mixer supports up to 48 configurable faders. Each fader can be assigned any audio source in the mixer.

### To Set the Number of Configurable Audio Faders (Channel)

Set the number of audio faders, or channels, that the mixer has.

1. Click **Navigation Menu > Configuration > System > Global**.



2. In the **Conf Audio Channels** field, select the number of configurable faders you want on the audio mixer.

### To Set Up Audio Faders

Assign audio sources to each fader in the mixer.

1. Click **Navigation Menu > Audio Mixer > Config**.



2. In the **Fader Config** area, click the **Fader Source** button for the fader you want to

assign an audio source to and click the source you want to assign.



- **X** – SDI audio sources
- **ClipPlyr** – audio from clip player
- **MX** – Media-Store audio sources
- **AESX** – AES source from each ABM
- **ABMX** – analog audio source from each ABM

**Tip:** You can rename a fader by entering a new name in the **Label** field.

3. Click the **Audio Source** button and click the stream pair that you want to use.

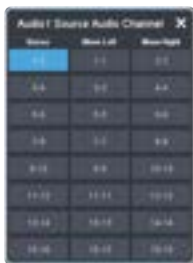

- **Stereo** — select the stereo pair that you want to use.
  - **Mono Left** — select the left mono pair you want to use. The left channel audio is put on both the left and right channels.
  - **Mono Right** — select the right mono pair you want to use. The right channel audio is put on both the left and right channels.
4. Toggle the **AFV Trans** button to either have the audio sources fade in and out (**AFV Fade**) or have a cut between the audio sources (**AFV Cut**) when the associated video source is taken on or off-air.
    - **AFV Fade** — the audio source level is taken down (going off-air) or up (going on-air) as the transition progresses. The rate of the audio fade is tied to the length of the video transition.
    - **AFV Cut** — the audio source is cut on-air at the beginning of the transition (going on-air) or cut off-air at the end of the transition (going off-air).

**Note:** Each audio source is transitioned according to how the AFV transition is set. For example, if Audio 1 is set to

*AFV Cut and Audio 2 is set to AFV Fade and you perform a transition from Audio 1 to Audio 2, Audio 1 will remain on and cut off at the end of the transition and Audio 2 will fade in through the transition.*

5. Click the **AFV Trigger** button and select the video source(s) that you want the audio transitions to follow. By default, the audio follows the video it is embedded in. You can select multiple sources.



6. Click the **Tone Freq** button and select the frequency you want to use for the test tone on this channel. The test tone can be turned on from the main audio mixer interface.
7. Click a **Processing Order** button for an audio fader to select whether the equalizer (**EQ**) is applied first, or if the compressor/limiter (**C/L**) is applied first for that fader. The noise gate (**NG**) is always applied upstream.

**Tip:** You can use the **Processing Order** buttons for **All** (at the top) to change the processing order for all audio faders.

## To Assign Audio Channels to Mix Layers

Select which audio sources are visible on each mixer layer.

1. Click **Navigation Menu > Audio Mixer > Config**.
2. In the **Mixer Config** area, click the mixer layer tab (**Main, Aux X**) you want to show or hide audio faders on.



3. Uncheck the **Visible** box to hide a fader on the selected layer.
4. Change the order of the audio faders on the mixer layer by moving an audio source **Up** (left) or **Down** (right) in the list.

*Tip: To change the name of a mixer layer, click **Labels** and enter a new name in the field for the mixer layer you want to change the name for. If you click **Labels** again you will see the new name applied to the mixer layer selection button.*

### To Configure the Analog Inputs

Each analog input on the ABM can be configured independently.

1. Click **Navigation Menu > Audio Mixer > Config**.
2. In the **ABM Input Config** area, click **Preamp**.



3. Click the **Gain** button for the analog input you want to configure.

*Tip: When you have multiple ABMs, the analog inputs are labelled by the ABM and input they are on. For example, Analog 2:5 is analog input 5 on ABM 2.*

4. Use the **Gain** slider to adjust the amount gain (loudness) that is applied to the input audio channel before the mixer.



5. Click a **Phantom (48V)** button to apply 48V to the analog input XLR jack (**On**) to power a microphone (condenser microphone). Click **Off** to not have phantom power applied to the analog input.



*Important: Ensure Phantom Power is off when using line in from an audio device over XLR. Use phantom power for mic only.*

6. Click a **Pad (-20dB)** button to apply -20dB of attenuation to the input signal (**On**) to prevent clipping of very loud signals.

### To Configure the ABM Input Audio Delay

Each input on the ABM can have an audio delay applied to it.

1. Click **Navigation Menu > Audio Mixer > Config**.
2. In the **ABM Input Config** area, click **Delay**.





- Click on the field next to the audio input that you want to apply a delay to and enter the delay, in frames. A maximum delay of 14 frames is supported.

*Tip: When you have multiple ABMs, the inputs are labelled by the ABM and input they are on. For example, Analog 2:5 is analog input 5 on ABM 2.*

## To Configure Audio Outputs

Audio signals can be embedded in video both internal and external video outputs.

- Click **Navigation Menu > Configuration > Outputs**.



- Click the **Audio Mix** button for the video output you want to assign an audio source to and select the audio source.

*Tip: Assign audio channels to the SDI outputs used for the ABMs from the **ABM** page.*

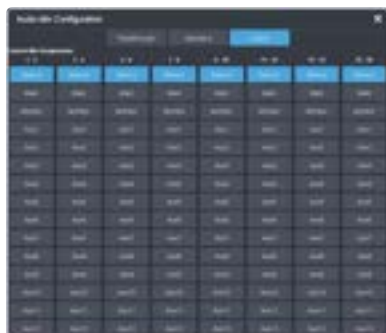

- **Passthrough** — embedded audio is passed through from the input source. Not available for MultiViewer outputs.
- **Standard** — embed all audio mixes from the internal audio mixer.
- **Custom** — select which audio source will be embedded on each stereo pair.
  - **Silence** — embed silence.
  - **Main** — embed the main audio mix from the internal audio mixer.
  - **Monitor** — embed the monitor mix from the internal audio mixer.
  - **Aux X** — embed the audio from Aux Bus X.

## To Configure ABM Audio Outputs

Audio signals are assigned to the outputs of each ABM as well as embedded in the video SDI-Audio loop.

- Click **Navigation Menu > Configuration > Outputs**.



- Click the **Analog** or **AES** button for the ABM you want to assign a source to and select the audio source.

*Note: If you only have a single ABM, the label **Audio Mix** is shown instead of the number of the ABM.*

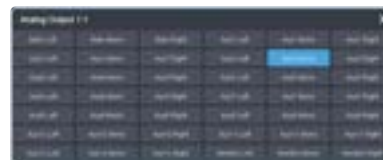

*Note: The AES outputs support stereo outputs.*

- **Main** — embed the main audio mix from the internal audio mixer. For the analog outputs you can choose the left, right, or mono channel.
- **Monitor** — embed the monitor mix from the internal audio mixer. For the analog outputs you can choose the left, right, or mono channel.
- **Aux X** — embed the audio from Aux Bus X. For the analog outputs you can choose the left, right, or mono channel.

## Noise Gate

The audio noise gate allows you to attenuate audio levels that are below a set threshold. These are often used to reduce background noise from the audio output signal. The noise gate does not remove the noise, but attenuates the entire signal when it is below the set threshold. When the input audio level is below the threshold the noise gate is closed and the attenuation is applied. When the input audio level passes above the threshold, the gate opens and the attenuation is removed. You can adjust how quickly the attenuation is removed once the threshold is surpassed as well as how

quickly it is applied when the audio level drops below the threshold.

**Note:** The noise gate is the first audio processing that is applied to the signal.

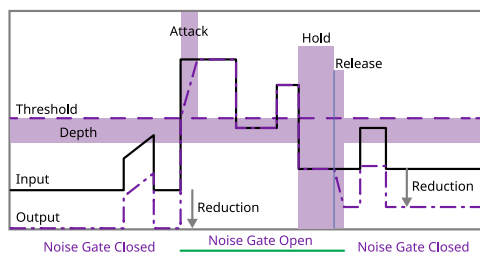

## To Configure a Noise Gate

Apply a noise gate to the audio level to prevent background noise.

1. Click **Navigation Menu > Audio Mixer > Effects > Noise Gate.**



**Tip:** To the left of the controls is a gain meter for the current channel. You can use this to see how your adjustments are affecting the audio.

2. Click the audio source button at the bottom left of the page and select the audio channel that you want to apply a noise gate to.

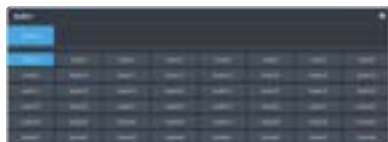

**Tip:** Click **Default** and click **All Channels** to default the noise gate for all channels or **Current Channel** to default it for only the currently selected channel.

**Tip:** Click **Back to Mix** to return to the mixer page.

3. Click **Bypass** to turn bypass off and have the noise gate applied to the selected audio channel.

**Tip:** The **NG Closed** indicator warns you if noise gate is closed and the audio signal is being attenuated.

4. Set up the noise gate as required.

Parameter	Description
<b>Threshold</b>	Select the level (-dB) at which the noise gate opens.

Parameter	Description
<b>Depth</b>	Select the level that the audio signal must go below the threshold before the noise gate is triggered to close.
<b>Reduction</b>	Select the amount of attenuation/gain (dB) that you want to reduce the audio signal by when the noise gate is closed (below the threshold).
<b>Attack</b>	Select the amount of time (ms) you want to pass between when the noise gate is triggered to open (pass the threshold) and the attenuation being fully released.
<b>Hold</b>	Select the amount of time (s) between when the noise gate is triggered to close (level is below the Depth) and the Release is applied.
<b>Release</b>	Select the amount of time (ms) you want to pass after the Hold is applied and the gate is fully closed (full Reduction is applied).

## Ducking and Talkback

The audio ducking and talkback use the noise gate to attenuate the background audio of a mix when a selected channel is active. This can be done automatically when a selected channel comes up above a threshold (Ducking), or manually (Talkback).

### Ducking

Ducking is applied to the mix when audio channel that ducking is set on rises above a threshold. Ducking is often used for voice-overs or announcement, the background mix is ducked when the announcer starts talking and returns to the previous level when the ducking channel. The setting for ducking are the same as for noise gate except that when the ducking channel passes the threshold, the mix is ducked down by the reduction amount and the ducking channel is untouched.

When ducking is active for a channel the **Mute** button is replaced with **Ducking**. When the **Ducking** button is off, the channel is muted and ducking is not applied. When the **Ducking** button is on, the channel is unmuted and the mix will be ducked when the ducking channel passes the threshold.



### To Configure Ducking

Apply ducking to the channel that you want to use to duck the mix that the channel is used on.

1. Click **Navigation Menu** > **Audio Mixer** > **Effects** > **Noise Gate**.



2. Click the audio source button at the bottom left of the page and select the audio channel that you want to apply ducking to.

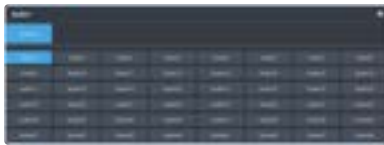

*Tip: Click **Default** and click **All Channels** to default the ducking for all channels or **Current Channel** to default it for only the currently selected channel.*

*Tip: Click **Back to Mix** to return to the mixer page.*

3. Click **Ducking Mode** to turn bypass off and have the ducking applied to the selected audio channel.
4. Set up ducking as required.

Parameter	Description
<b>Threshold</b>	Select the level (-dB) at which the ducking is applied to the mix.
<b>Depth</b>	Select the level that the audio signal must go below the threshold before the ducking is removed.
<b>Mix Reduction</b>	Select the amount of attenuation/gain (dB) that you want to reduce the mix by when the ducking is applied (above threshold).
<b>Attack</b>	Select the amount of time (ms) you want to pass between when ducking is triggered to apply (pass the threshold) and the attenuation being fully applied to the mix.

Parameter	Description
<b>Hold</b>	Select the amount of time (s) between when ducking is triggered to release (level is below the Depth) and the Release is applied.
<b>Release</b>	Select the amount of time (ms) you want to pass after the Hold is applied and the ducking is fully released (mix back to normal levels).

### Talkback

Talkback is applied to the mix when an audio channel that is set to talkback is manually triggered. Talkback is often used in a studio for internal communications, the background mix is ducked when the talkback button is pressed so that talent can hear the director over the background. Setting for talkback are similar to ducking except there is no threshold or depth.

When talkback is active for a channel the **Mute** button is replaced with **Talkback**. When the **Talkback** button is off, the channel is muted and talkback is not applied. When the **Talkback** button is held, the channel is unmuted and the mix will be attenuated for as long as the button is held.



### To Configure Talkback

Apply talkback to the channel that you want to use to manually duck the mix that the channel is used on.

1. Click **Navigation Menu** > **Audio Mixer** > **Effects** > **Noise Gate**.



2. Click the audio source button at the bottom left of the page and select the audio channel that you want to apply talkback to.

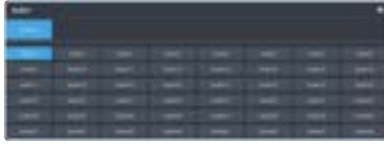

**Tip:** Click **Default** and click **All Channels** to default the talkback for all channels or **Current Channel** to default it for only the currently selected channel.

**Tip:** Click **Back to Mix** to return to the mixer page.

### 3. Click **Talkback Mode**.

**Note:** You must click **Bypass** on the Noise Gate to apply talkback to the channel.

### 4. Set up talkback as required.

Parameter	Description
<b>Threshold</b>	Not used by talkback.
<b>Depth</b>	Not used by talkback.
<b>Mix Reduction</b>	Select the amount of attenuation/gain (dB) that you want to reduce the mix by when the talkback is applied ( <b>Talkback</b> button held).
<b>Attack</b>	Select the amount of time (ms) you want to pass between when talkback is triggered to apply and the attenuation being fully applied to the mix.
<b>Hold</b>	Select the amount of time (s) between when talkback is released ( <b>Talkback</b> button is released) and the Release is applied.
<b>Release</b>	Select the amount of time (ms) you want to pass after the Hold is applied and the talkback is fully released (mix back to normal levels).

## Audio Equalization

The audio equalizer (EQ) allows you to enhance the sound quality of audio sources. An independent stereo equalizer is available for every audio fader in the system and allows for adjustment in four bands (low-shelf, mid-range 1/2, high-shelf).

### To Configure an Equalizer

A stereo equalizer is available for every audio source. You can only adjust a single equalizer at a time.

#### 1. Click **Navigation Menu** > **Audio Mixer** > **Effects** > **Equalizer**.



#### 2. Click the audio source button at the bottom left of the page and select the audio channel that you want to apply an equalizer to.

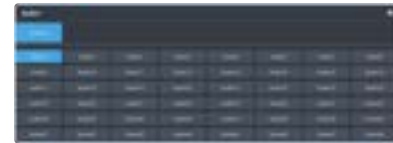

**Tip:** Click **Default** and click **All Channels** to default the equalizer for all channels or **Current Channel** to default it for only the currently selected channel.

**Tip:** Click **Back to Mix** to return to the mixer page.

#### 3. Click **Bypass** to turn bypass off and have the equalizer applied to the selected audio channel.

**Tip:** The **EQ Clip** indicator warns you if clipping is occurring in the Equalizer stage for the selected audio source.

#### 4. Set up the equalizer as required.

Parameter	Description
<b>Low Shelf</b>	Adjust the gain of the low frequency band.  <b>Tip:</b> You can also move the <b>L</b> point around on the graph to adjust the low shelf values.  <ul style="list-style-type: none"> <li><b>Gain</b> — set the audio level of the frequency band (-20dB to 20dB).</li> <li><b>Max Freq</b> — click ^ and set the maximum frequency that you want the low shelf audio band limited to (20Hz to 1kHz).</li> </ul>
<b>Midrange 1</b>	Adjust the gain of a midrange frequency band.  <b>Tip:</b> You can also move the <b>M1</b> point around on the graph to adjust the midrange 1 values. The dot below the <b>M1</b> allows you to adjust the Q ratio.  <ul style="list-style-type: none"> <li><b>Gain</b> — set the audio level of the frequency band (-20dB to 20dB).</li> <li><b>Center Freq</b> — click ^ and set the middle frequency of the audio band (20Hz to 20kHz).</li> <li><b>Q</b> — click ^ and set the Q ratio.</li> </ul>

Parameter	Description
<b>Midrange 2</b>	<p>Adjust the gain of a midrange frequency band.</p> <p><i>Tip: You can also move the <b>M2</b> point around on the graph to adjust the midrange 2 values. The dot below the <b>M2</b> allows you to adjust the Q ratio.</i></p> <ul style="list-style-type: none"> <li><b>Gain</b> — set the audio level of the frequency band (-20dB to 20dB).</li> <li><b>Center Freq</b> — click ^ and set the middle frequency of the audio band (20Hz to 20kHz).</li> <li><b>Q</b> — click ^ and set the Q ratio.</li> </ul>
<b>High Shelf</b>	<p>Adjust the gain of the high frequency band.</p> <p><i>Tip: You can also move the <b>H</b> point around on the graph to adjust the high shelf values.</i></p> <ul style="list-style-type: none"> <li><b>Gain</b> — set the audio level of the frequency band (-20dB to 20dB).</li> <li><b>Min Freq</b> — click ^ and set the minimum frequency that you want the high shelf audio band limited to (20kHz to 1kHz).</li> </ul>

## Compressor / Limiter

The audio compressor allows you to restrict audio levels from passing a threshold level. These are often used to prevent digital clipping of audio levels that are too high for output equipment. Once the threshold is reached, the compressor starts to reduce the gain at a specific ratio. The higher the compression ratio, the harsher the reduction in gain. The compression continues until the audio level falls below the threshold. You can adjust how quickly the compressor is applied once the threshold is surpassed as well as how long after the level drops below the threshold that the compressor is still applied.

*Tip: The compressor is said to be acting as a limiter when the compression ratio is set very high, or to infinity, and the attack time is set very low. This has the effect of causing a very abrupt flattening of the audio level once the threshold is reached.*

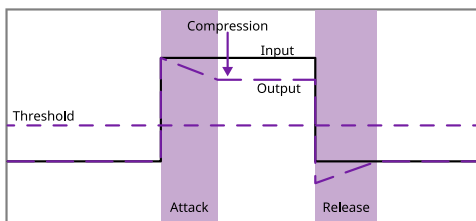

## To Configure a Compressor/Limiter

Apply compression to the audio level to prevent digital clipping.

1. Click **Navigation Menu > Audio Mixer > Effects > Compressor Limiter**.



*Tip: The **CL Clip** indicator warns you if clipping is occurring in the Compressor stage for the selected audio source.*

2. Click the audio source button at the bottom left of the page and select the audio channel that you want to apply a compressor to.

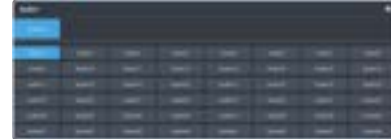

*Tip: Click **Default** and click **All Channels** to default the compressor for all channels or **Current Channel** to default it for only the currently selected channel.*

*Tip: Click **Back to Mix** to return to the mixer page.*

3. Click **Bypass** to turn bypass off and have the compressor applied to the selected audio channel.
4. Set up the compressor as required.

Parameter	Description
<b>Threshold</b>	Select the level (dB) at which the compressor is applied.
<b>Compression</b>	Select the ratio for the amount of compression you want to apply. The higher the ratio the more compression is applied to lower the level. At <b>infinity</b> the audio level is limited to the threshold.
<b>Attack</b>	Select the amount of time (ms) you want to pass between the level surpassing the threshold and the full compression ratio being applied.
<b>Release</b>	Select the amount of time (ms) you want to pass between the level falling below the threshold and the compression ratio returning to 1:1 (no compression applied).
<b>Makeup</b>	Increase the gain (dB) of the audio after compression.

---

**Tip:** The **Gain Reduction Meter** at the bottom shows how much gain is being reduced by the compressor. The **Src** (Source) meter to the left shows the gain before the compressor is applied.

# Switcher Sets

The switcher stores configuration and operation data in a number of registers that contain the individual entries for items such as memories or personality settings. These registers can be stored as a single archive file, or as a register set that contains all the individual register of that type; all memories for example. These files are stored into Sets on USB drive. Different Sets can be created for different shows or applications, allowing you to quickly locate and recall the switcher configurations.

The switcher stores information in the following registers:

- **Memory** — contains all the memories for ME, MiniME™, and Canvas.
- **Custom Control** — contains all the custom control banks and macros.
- **Sequences** — contains of all the sequences created in the sequencer.
- **UltraScene** — contains all of the UltraScene memories.
- **Installation** — contains all the external device setup, and software settings for the switcher.
- **Personality** — contains all the user interface settings, such as transition rates, that are stored under the **Personality** menu. Some personality settings are specific to the control panel and can be stored independently if you are working with a MultiPanel system.

*Tip: Sets are stored differently if they are stored directly to the USB or exported. Sets stored directly to the USB are located in folders, but sets that are exported are archived in a TAR file. To interchange between the two you will need an archive program, such as 7-Zip, to extract the files from the TAR file or archive the files into a TAR file. Inside the TAR is the Set folder (named how you want the set named on the switcher) and component sub folders.*

## To Store a Set

Switcher Sets can only be stored to a USB drive. The USB drive must be present before you try to store the Set.

*Note: If you are updating an older setup file, you must perform a Recall All followed by a Store All. This updates the setup files the latest format. You can then make changes and store to individual registers if needed.*

*Tip: The switcher provides 10 empty sets by default. Additional sets can be created if you rename the sets on the USB from a separate computer.*

1. Insert a USB drive into the USB Port on the frame. You must wait 5 seconds for the switcher to recognise the USB drive.

*Tip: If you do not have a USB drive, you can store the working set to temporary storage. This set will be lost when the switcher restarts, but can be exported to an external computer.*

2. Click **Navigation Menu > Configuration > System > Save Sets**.

*Tip: Click **Refresh Sets** to update the list of available sets on the USB.*



3. Click an **Available Sets** button for the set you want to store the switcher registers to. If a USB is not available, temporary storage is used.
4. Click a **Save Set to USB** button to save that register to the selected set. If the button is shown in brown, that register already exists in the set and will be overwritten.
  - **All** — store all registers to the set.
  - **Memories** — store only the memory registers to the set.
  - **Customs** — store only the custom control registers to the set.
  - **Sequences** — store only the Sequencer registers to the set.
  - **UltraScenes** — store only the UltraScene registers to the set.
  - **Installation** — store only the installation registers to the set.
  - **Personality** — store only the personality registers to the set.

5. Click **Yes**.

The registers are stored to the set on the USB.

*Tip: You can export the switcher set to your local computer in the **Export Set From Available Sets** area. Click **Export As** and navigate to the folder where you want to store the file and enter a name and click **Open**. It may take several minutes for the set to download to your computer.*

## To Load a Set

Switcher Sets can only be loaded from a USB drive. The USB drive must be present before you try to load the settings.

**Note:** If you are updating an older setup file, you must perform a Recall All followed by a Store All. This updates the setup files to the latest format. You can then make changes and store to individual registers if needed.

1. Insert your USB drive into the USB Port on the frame. You must wait 5 seconds for the switcher to recognise the USB drive.

**Tip:** If you do not have a USB drive, you can recall the set from temporary storage. This set will be lost when the switcher restarts. Importing a set from an external computer will be stored in the temporary storage.

2. Click **Navigation Menu > Configuration > System > Load Sets.**

**Tip:** Click **Refresh Sets** to update the list of available sets on the USB.



**Tip:** You can import a switcher set from your local computer in the **Import Set to Available Sets** area. Click **Import As** and navigate to the folder where the set is stored and click **Open**. It may take several minutes for the set to upload to the switcher.

3. Click an **Available Sets** button to select the set you want to load the switcher register from. If there is only one set on the USB then these buttons will not be present.
4. Click a **Load Set from USB** button to load that register. Only those registers that are present in the set are shown.
  - **All** — recall all registers from the set.
  - **Memories** — recall only the memory registers from the set.
  - **Customs** — recall only the custom control registers from the set.
  - **Sequences** — recall only the Sequencer registers from the set.
  - **UltraScenes** — recall only the UltraScene registers from the set.
  - **Installation** — recall only the installation registers from the set.
  - **Personality** — recall only the personality registers from the set.
5. Click **Yes**.

## Importing a Set from Carbonite

Import a switcher set from Carbonite.



**Important:** This feature is only available with sets exported from Carbonite version 15.6.0 or higher.

When you export the working set from Carbonite it is converted into a format that is compatible with Ultra. Not all setting can be converted and should be reviewed after the set is imported.

### Keep the following in mind:

Keep the following in mind when importing a set from Carbonite Black:

- Modified color schemes in Carbonite cannot be imported into Ultra or Ultrix Carbonite.
- If a video source used in a set (custom control, bus map, or GPI) does not exist in the switcher it is imported to, black will be selected instead.
- When a set is imported to Ultra from Carbonite the ME numbering will be different. In Carbonite the highest numbered ME is the program ME. In Ultra ME P/P is the program ME.
  - ME 1 -> ME P/P
  - ME 2 -> ME 1
  - ME 3 -> ME 2
- When a Memory is imported to Ultra or Ultrix Carbonite from Carbonite the ME numbering will be different. Only memories are mapping in this way.
  - ME 1 -> ME 2
  - ME 2 -> ME 1
  - ME 3 -> ME P/P
- When a set is imported to Ultra from Carbonite some outputs (such as PGM, PRV, and CLN) are not available and must be re-assigned. For example, ME P/P replaces PGM.
- Custom controls imported to Ultra from Carbonite cannot have memory recall events. These custom controls will not be imported.
- When exporting memories or custom controls that load Media-Store media items, the media item IDs and attributes must match between the switchers you are exporting from and importing to. This information is not included in the sets. If the media items do not match, the memories and custom controls may load the wrong media items or with the wrong attributes.



- When loading exported memories or custom controls that load Media-Store media items with an alpha, the alpha will be loaded twice. Carbonite uses one of the other Media-Store channels to load the alpha. Ultra or Ultrix Carbonite have dedicated alpha channels for each Media-Store channel. When the exported memory or custom control is loaded in Ultra or Ultrix Carbonite the alpha is loaded in the correct alpha channel as well as the channel that Carbonite was using for the alpha.
- If you do not have a USB drive, the set is imported to the temporary storage set. Temporary storage is cleared when the switcher reboots.

- **Sequences** — recall only the Sequencer registers from the set.
- **UltraScenes** — recall only the UltraScene registers from the set.
- **Installation** — recall only the installation registers from the set.
- **Personality** — recall only the personality registers from the set.

5. Click **Yes**.

### To Import a Set from Carbonite

Import the working set that was exported from Carbonite.

1. Insert your USB drive into the USB Port on the frame. You must wait 5 seconds for the switcher to recognise the USB drive.
2. Click **Navigation Menu > Configuration > System > Load Sets**.

*Tip:* Click **Refresh Sets** to update the list of available sets on the USB.



*Tip:* You can import a switcher set from your local computer in the **Import Set to Available Sets** area. Click **Import As** and navigate to the folder where the set is stored and click **Open**. It may take several minutes for the set to upload to the switcher.

3. Click the **Available Sets** button for the set you exported from Carbonite. If there is only one set on the USB then these buttons will not be present.
4. Click a **Load** button to load that register. Only those registers that are present in the set are shown.
  - **All** — recall all registers from the set.
  - **Memories** — recall only the memory registers from the set.
  - **Customs** — recall only the custom control registers from the set.

---

## Media-Store

The MediaManager interface to the Media-Store allows you to load stills, animations, or audio files from the USB drive and make them available across all MEs. Up to 4 (4 in UHDTV1) independent channels of video with alpha for playout of stills and animations are available switcher-wide.

*Tip: The legacy web version of MediaManager can still be accessed by using a Google Chrome™ web browser to navigate to the IP address of the frame. This feature can be disabled by setting **Web Media Manager** (Click **Navigation Menu** > **Configuration** > **System** > **Global**) to **Disable**. The switcher must be re-started for the change to be applied.*

### Keep the following in mind:

Keep the following in mind when working with Media-Store:

- A still, animation, or audio can be loaded either by browsing the file system, or by entering the still number using the pattern buttons.
- You can clear a Media-Store channel by loading media number 000.
- If you are loading an Auto Key into a Media-Store channel, you must have another Media-Store channel associated with the current one to load the alpha into.
- An FTP connection using RossLinq can be created from an external device directly to a Media-Store channel on the switcher.
- If you delete a media item from the USB, you may have to load that media item into a Media-Store channel for the switcher to prompt you to delete the media item from the database.
- Media items must be created in the same color gamut and dynamic range that they are intended to be used in on the switcher. If a media item is created in one color space and the switcher is operating in another, the media item may not appear correctly.
- If you delete or rename a media item on the USB while it is still inserted into the switcher, you must attempt to load the old file to clear that entry from the database.
- The legacy web version of MediaManager still supports playlists.
- Media-Store attributes are stored in the database for a media item. These are the default settings that will be used every time that media item is loaded into a media

channel. When a media item is loaded into a channel you can override the database settings. These override settings are only applied to the media item while it is loaded into the media channel and are not stored to the database entry.

- You can only change the X and Y position of a media item that is smaller than the full size of the screen.

## Working With Media-Store Animations

Media-Store animations can be used for animated backgrounds, branding "bugs", or media transitions. You can set up an animation to loop, play automatically when taken on-air, play in reverse, or even play at different speeds.

*Tip: You can play an animation manually from a control panel by selecting the source button for the Media-Store channel with the animation you want to play, and pressing **Run** on the 3-knob menu. The knob changes to **Stop** as the animation is playing.*

### Keep the following in mind:

Keep the following in mind when working with Media-Store animations:

- When you load an animation to an off-air Media-Store channel, or the animation goes off-air with a transition, the preview shows the cut point (**CutFr**) for that animation, and not the first frame of the video.
- You can manually cycle through frames by turning the **Run** knob while the animation is stopped.
- Double-pressing the **Run** knob stops playback and re-cues the animation to the first frame.
- You can shuttle forwards and backwards through the animation by turning the positioner clockwise or anti-clockwise when the animation is stopped, if your control panel has a positioner with a z-axis. Shuttle speed is increased and decreased by turning the positioner more or less in each direction.
- You can run or stop an animation by pressing the positioner button, if your control panel has a positioner with a button.

## Working With Media-Store Audio

Audio can be added to the playout of a Media-Store channel either by loading the file directly, or by naming the audio file the same as the animation or still you want it to play out with.

When you load the still or animation, the switcher will automatically load the audio file of the same name.

### Keep the following in mind:

Keep the following in mind when working with Media-Store audio:

- Media-Store audio is available to the audio mixer and the AES outputs on the frame.
- Audio files must be 20-bit or 24-bit wav files at a 48kHz sample rate.
- Audio files must be in the same folder and have the same name as the still or animation they are to be associated with.
- An audio file does not need to be of the same length as the animation it is associated with.
- A still with audio or audio only have the Auto Play and Looping attributes. These apply to the audio layout.
- The looping time of an animation with audio is the length of the animation.
- A Media-Store channel can be loaded with Audio only.

## Media-Store Cache Manager

View all the media that is loaded into a Media-Store cache and remove unused items.

The cache manager allows you to review the media that is currently loaded into each cache, including name, id, size in cache, and frames, as well as remove items to free up space. The current amount of free space in the selected cache is shown at the bottom left.

Channels 1 and 3 share one cache and channels 2 and 4 share another. Click **Media Store X&Y** to switch between the caches.



**Tip:** To remove an item from the cache, select the item you want to remove and click **Remove**.

**Note:** A media item can only be removed from the cache if it is not currently loaded into a Media-Store channel.

## Media-Store File Specifications

Media items can be in TGA, PNG, or JPG file formats. For animations, the files must be numbered to indicate the order they go in, and the name and the number must be separated with an underscore. For audio, 20-bit or 24-bit WAV files of the same name as the still or animation are used to associate audio with a still or animation.

For example, the following files are treated as a single animation named Anim that is 100 frames long:

- Anim\_001.tga
- Anim\_002.tga
- Anim\_003.tga
- ...
- Anim\_100.tga

**Note:** Media items must be created in the same color gamut and dynamic range that they are intended to be used in on the switcher. If a media item is created in one color space and the switcher is operating in another, the media item may not appear correctly.

**Note:** An animation must start with **\_001** at the end of the name of the first frame.



**Important:** File or folder names cannot contain symbols such as ! @ # & \* ( ) / , ? \ ' " and cannot start with an underscore (\_). Files or folders that start with a period (.) are hidden.

### Animation File Size

The number of frames that an animation can have depends on the raster size of the frames in the animations. Compressed image formats are uncompressed inside the switcher and an alpha is applied when the file is loaded into the Media-Store.

**Note:** Media-Store channels 1 and 3 share one block of RAM and channels 2 and 4 share another. As you load an animation into one channel in the block, the amount of RAM available to the other channel is reduced.

Raster	M1	M3	M2	M4
3840×2160 (UHDTV1)	123	--	123	--
1920×1080 (1080p)	494		494	
1280×720 (720p)	1105		1105	

## Loading Stills or Animations

Stills or animations can be loaded into Media-Store channels from the USB by navigating to the file in MediaManager. MediaManager creates and maintains a database of the media items on the USB, as well as the setting for each media item and a thumbnail.

**Note:** The internal cache is used for sample images only and cannot be used to store user stills or animations.

### To Load a Media Item

Media items are loaded from the USB drive into a Media-Store channel from MediaManager

**Note:** Media items must be created in the same color gamut and dynamic range that they are intended to be used in on the switcher. If a media item is created in one color space and the switcher is operating in another, the media item may not appear correctly.

1. Insert your USB drive into the USB Port on the switcher. You must wait 5 seconds for the switcher to recognise the USB drive.  
If the files on your USB are new, it takes about 2 seconds per file for the switcher to generate the thumbnail for the MediaManager. Once all the thumbnails are generated, they are displayed in the MediaManager window.
2. Click **Navigation Menu > MediaManager**

**Tip:** The MediaManager can also be accessed from Live Assist (Click **Navigation Menu > Live Assist > Media > MediaManager**). The Live Assist version follows Media-Store source selections on the panel.



3. Navigate to the folder containing the media item you want to load into a Media-Store channel.

**Note:** The first time you navigate to a folder it may take a few moments for the Media-Store to scan the files and build the database entries.

**Tip:** If you have added media items to a folder on the USB but they do not appear on the menu, click **Refresh** to scan the folder for any new files.

**Tip:** You can upload a media item from your computer to the selected folder on the USB. In the **Still Upload** area click **Browse** and navigate to the media item you want to upload to the USB. Click **Open** and then **Upload File**.

All the media items in that folder are shown in the center area of the page.

4. Drag the media item onto the Media-Store channel you want to load it in.

**Tip:** The film-strip symbol (🎞️) indicates that the media item is an animation, the key symbol (⌨️) indicates that the media item has an alpha, and the speaker symbol (🔊) indicates that the media item has audio associated with it, or is audio only.

## Deleting a Media Item

Delete media items to remove them from the USB and database.

### To Delete A Media Item

Delete a media item from the USB. You can only delete a single item at a time and you cannot delete the internal sample items.

1. Click **Navigation Menu > MediaManager**
2. Navigate to the folder on the USB that has the item you want to delete and select the media item that you want to delete.
3. In the **Item Details** area, scroll to the bottom.



4. Click **Delete File** and **OK**.

## MediaManager Channel Control

Once a media item is loaded into a channel you can control the playout for the media item from MediaManager.

**Note:** Playlists are not supported by MediaManager in DashBoard at this time.



**Tip:** The background of the channel areas tallies the on-air status of the Media-Store channel. Red for on-air and green for on-preview.

The label below the thumbnail of the media item shows the name of the file, the number of frames in the animation, and the media ID. In this example, the name of the media item is **Lobster**, it is **5** frames long, it is located on the USB (**U1**) and has a media ID of **001**.

The controls below the name allow you to set how the animation plays out as well as eject the current media item.

- **Play** — play the animation.
- **Loop** — set the animation to start playing again from the beginning when it reaches the last frame.
- **Play Direction** — set the animation to play in the forward or reverse direction.
- **Re-cue** — re-cue the animation to the first playout frame.
- **Eject** — eject the current media item from the channel.

## Media-Store Attributes

Attributes are applied to the media item in the database and in each Media-Store channel. Where the attributes are being applied is shown in the upper left corner of the area. If you adjust the attributes of the media item in one channel, these settings are not applied back to the database or to other channel if the same media item is loaded into more than one channel.



**Tip:** At the top of the **Item Details** frame the title indicates if the information shown applies to the media item loaded into the media channel (**MX**), or is from the media item in the database (**Database**).

### Buttons:

- **Autoplay** — play the animation automatically when the Media-Store channel is taken on-air.

- **Reverse** — set the animation to play in the forward or reverse direction.
- **Mute** — mute the audio associated with the media item.
- **Looping** — set the animation to start playing again from the beginning when it reaches the last frame.
- **Shaped** — set the alpha to be shaped, or unshaped when not selected.

### Fields:

- **Name** — the name of the media item as taken from the file name.
- **Width** — the width of the media item raster.
- **Height** — the height of the media item raster.
- **Alpha** — shows whether there is an associated alpha with the media item.
- **Number of Frames** — the number of frames in the animation.
- **Audio Channels** — the number of audio channels in the associated audio.
- **Media Number** — the media number of the media item.
- **X-Position** — set the horizontal position of the media item. Can only be applied if the media item is smaller than full screen.
- **Y-Position** — set the vertical position of the media item. Can only be applied if the media item is smaller than full screen.
- **Color Gamut** — shows the color mode that the switcher was operating in when the media item was added.
- **Dynamic Range** — shows the dynamic range that the switcher was operating in when the media item was added.
- **Cut Frame** — set the frame of the animation when used as part of a MediaWipe.
- **Thumb Frame** — set the frame of the animation that is used for the thumbnail.
- **Play Speed** — set the playout speed for the animation.

**Tip:** Click **Delete File** to delete the selected media item from the USB.

## Media-Store Capture

Still images can be captured from any input BNC, as well as the program, preview, and clean feed from any ME.

---

## To Capture a Still

1. Insert your USB drive into the USB Port on the switcher. You must wait 5 seconds for the switcher to recognise the USB drive.
2. Click **Navigation Menu > Live Assist > Media > Capture**.



3. Click **Media Store 1** or **Media Store 2** to select which Media-Store you want to use for the capture.
4. Click the **Display** button to select the mode you want the Media-Store in.
  - **E/E** — electronic-to-electronic, or record, mode allows you to capture a single frame media item.
  - **P/B** — playback mode allows you to review your single frame media item.
5. Click the **Source** button and select the video source you want to capture.
6. Click the **Alpha** button to select whether to include the alpha with the capture (**Yes**) or not (**No**). You must have an input BNC selected as the capture source to capture the alpha.
7. In the **Name** field, enter the name you want to give to the file. This will be the file name that the still is stored to on the USB.

*Note: File or folder names cannot contain symbols such as ! @ # & \* ( ) / , ? \ ' " and cannot start with an underscore (\_). Files or folders that start with a period (.) are hidden.*

8. Click a **Capture** button to capture the still.
  - **Capture+** — capture a still to the selected file name (**Name**) and increment the file name by one.
  - **Capture** — capture the still to the selected file name (**Name**).

*Note: Capture will overwrite any existing still with the same file name.*

# Clip Player

The clip player offers a single playout channel for compressed MPEG-4 AVC (ITU-T H.264) that can be assigned as a source on any bus in the switcher. Basic transport controls can be performed manually from the **Clip Player** page, using custom controls, or through AMP commands.

## Keep the following in mind:

Keep the following in mind when working with the clip player:

- Media items must be created in the same color gamut and dynamic range that they are intended to be used in on the switcher. If a media item is created in one color space and the switcher is operating in another, the media item may not appear correctly.
- The clip player is only available in the HD switcher modes.
- Do not copy a clip to the USB while a clip is playing. Copying a clip to the USB while the Clip Player is playing a clip can cause the clip to stutter or stop.
- The audio from the clip player is not available as an input to the audio mixer.

## Clip Specifications

Clip codecs, formats, switcher formats, and clip names.

The clip player supports clips in the ITU-T H.264 (MPEG-4 AVC) codec in specific HD video formats.

### Codecs

- ITU-T H.264 (MPEG-4 AVC)
  - **Profile** — Baseline, Constrained Baseline, Main, or High
  - **Version** — 4.1 or lower

### Clip and Video Formats

Only clip formats for 1280×720 are supported by the clip player. The clip frame rates that are supported by the clip player depend on the video format that the switcher is operating in.

*Note: Other clip and video format combinations may work in some applications, but playout quality cannot be guaranteed.*

*Note: The clip player does not support playing clips when the switcher is operating in a pSF video format.*

**Table 1: Supported Switcher Video Formats and Clip Resolution and Frame Rates**

Vid Format	1280×720 25FPS	1280×720 29.97FPS	1280×720 50FPS	1280×720 59.94FPS	1920×1080 59.94FPS	1920×1080 29.97FPS	1920×1080 30FPS
1080p 60Hz							
1080p 59.94Hz				✓	✓		
1080p 50Hz	✓		✓				
1080p 30Hz							✓
1080p 29.97Hz		✓				✓	
1080p 25Hz	✓		✓				
1080p 24Hz							
1080p 23.98Hz							
1080pSF 30Hz							
1080pSF 29.97Hz							
1080pSF 25Hz							
1080pSF 24Hz							
1080pSF 23.98Hz							
1080i 59.94Hz		✓					
1080i 50Hz	✓						
720p 59.94Hz				✓			
720p 50Hz			✓				

### Clip Names

The name can contain letters, numbers, spaces, dashes, underscores, and, periods, but should not contain symbols.

*Tip: A maximum of 255 clip names can be displayed.*

### Audio

The clip player supports playout of the first two channels of embedded audio on either of the AES outputs. Audio cannot be embedded in the video playout and must be 24-bit at 48kHz.

The clip player audio must be assigned to the AES port for audio playout.

The clip player audio is not available as an input to the audio mixer.

## Clip Player Interface

The clip player interface (Click **Navigation Menu > Live Assist > Media > Clip Player**) provides basic transport controls and clip management.

*Tip: Click **Reset Clip Player** to reset the clip player if it is in a non-responsive state.*



### Transport Controls

1. **Step Back** — Step backwards by 1/10 second.
2. **Play/Pause** — Play the current clip forward at 1-times normal speed.
3. **Step Forward** — Step forward by 1/10 second.
4. **Re-cue** — Re-cue the current clip to the first frame.
5. **Eject** — Eject the current clip from the clip player channel. The thumbnail preview shows no clip selected and the output is black.
6. **Loop** — Toggle loop mode on where the clip starts playing again from the start after it reaches the end.

The progress bar below the transport control buttons shows the progress of the playout of the clip. The number at the left of the progress bar is clip timecode, and the number at the right is the time remaining. You can click on any point on the progress bar to jump to that point in the clip.

*Tip: Click **Capture Thumbnail** to use the current frame of the clip as the thumbnail for the clip in the clip player.*

### Clip Control

Below the transport controls are a number of buttons for managing clip lists and setting the pre-roll time.

- **Refresh Clip List** — Refreshes the list of clips found on the USB. If you add a clip directly to the USB via FTP, you must refresh the list for the new clip(s) to appear in the list.
- **Capture Thumbnail** — Captures the current frame of the clip for use as a thumbnail of the clip. You can use the progress bar to jump to the frame you want to use.
- **Clip Details** — Displays a popup with details on the video and audio properties of the clip that is currently loaded.
- **AMP PreRoll** — Enter the pre-delay (pre-roll) interval (in frames) that the switcher waits after the clip player starts playing and before taking the input source on-air. Depending on the clip you are playing, you may have to increase this value to ensure that your clip is playing just as it is transitioned on-air. This value is used with the **Roll Clip** transition functionality.

### Panel Control

When you select the clip player on a bus on the control panel, the menu follows and allows you to select and cue a clip. Press **NEXT** to access the additional commands.

1. Use the **Clips** knob to select the clip you want to load into the clip player.

*Tip: Press the **Clips** knob to refresh the clip list and jump to the first clip in the list. This is useful when you add or delete a clip from the directory.*

2. Press the **Cue** knob to cue the selected clip.
3. Press the **Play** knob to play the cued clip.
4. Press the **Stop** knob to stop the clip.
5. Press the **Lp On** knob to turn looping on.
6. Press the **Lp Off** knob to turn looping off.

### Custom Control

The Video Server custom controls can be used to control the clip player. When you are creating the custom control, select the **ClipPlyr** video server as the target device.

## To Load a Clip

Clips located in the video folder on the USB can be loaded into the clip player. Sub-folders are not supported at this time.

Clips must be located on the USB in the /clips/video folder. The switcher will create this folder if it does not already exist.





**Important:** Do not copy a clip to the USB while a clip is playing. Copying a clip to the USB while the Clip Player is playing a clip can cause the clip to stutter or stop.

**Note:** The clip player is only available in the HD switcher modes.

1. Click **Navigation Menu > Live Assist > Media > Clip Player.**

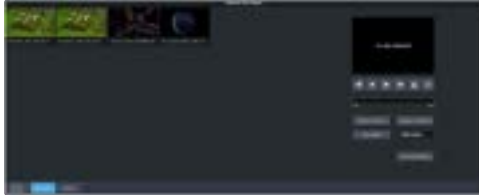

2. Click on the clip you want to load.

**Note:** The clips is loaded into the channel as soon as you click on it. If a clip is already playing it is ejected and the new clips is loaded.

**Tip:** If the clip you want to load does not appear in the list, click **Refresh Clip List**. The switcher re-scans the USB folder and updates the clip list.

**Tip:** You can use FTP to copy a clip to USB while it is still in the switcher. Refer to [To Create an FTP Connection](#) on page 86 for information on creating an FTP connection to the USB.

The clip is loaded and queued into the clip player.

3. Click **Clip Details** to view general, video, and audio information on the currently loaded clip.

# Custom Controls

Once programmed, a custom control (CC) can be played back by pressing a button. The custom control can be as simple as triggering an output GPI pulse, or as complex as recalling a specific memory register on an ME, performing a switcher transition, and selecting a group of keys.

You can record, edit, and run custom controls from the Custom Control node in DashBoard.

Refer to [Custom Control Events](#) on page 160 for information on available events.

## Recording/Editing Custom Controls

When you create a custom control, you record a series of events and special functions that are played back when you run the custom control. The process for creating a new cc and editing an existing one are the same, except when editing you have the option to insert events at different points in the existing cc.

Almost any action or setting can be stored in a custom control, with the following exceptions:

- Diagnostic Functions
- Confirmation Dialogs
- Panel-Specific Functions

**Note:** It is recommended that you use a control panel for recording custom controls.

### Keep the following in mind:

Keep the following in mind when recording custom controls:

- Some functions take time to perform and a pause should be added after the function to ensure that the command is completed before moving on to the next command.
- If you are recording a custom control from DashBoard, only new settings are recorded. If the current setting in DashBoard is the value you want to record, you need to select a different value and then select the value you want to use.

### To Record a Custom Control

A basic custom control records a series of events that are played out in the same order they are recorded.

1. Click **Navigation Menu > Custom Control > Editor**.



2. Click a **Bank** list item to select the bank that the custom control you want to record will be stored on.
3. Click a **Macro** list item to select the custom control that you want to record to. If the custom control already has a macro recorded, the name of the custom control is shown in the list.

**Tip:** You can rename both the custom control and the bank by entering a new name in the field next to the record button.

4. Click **Record**.

**Tip:** The switcher can be set so that each command is automatically separated from the previous command by a pause equal to the real-time delay between you entering commands. Refer to [To Set the CC Pause Mode](#) on page 75 for more information.

The **CC/UP** button on the control panel, as well as the button assigned to the CC on the bus, flash red when the CC is recording.

5. Insert the events you want to record. Events can be entered from the menu or from actions directly on the control panel.

Each custom control can have a maximum of 998 events, plus the End event.

**Note:** When the switcher runs a custom control, it attempts to execute each event in the custom control as quickly as possible. If an event takes time to complete, the event may not be complete before the switcher attempts to execute the next event. For example, if your custom control has a memory recall followed by a transition, a pause should be added between the memory recall and the transition to ensure that the memory is fully recalled before the transition is performed. The same applies if you want to add events after a transition.

6. Click **Stop Recording** to finish recording.

**Tip:** Click **Cancel** if you do not want to store your events to the custom control.

### To Edit a Custom Control

When editing a custom control, you can delete and insert events at any point in the custom control, or append events to the end.

**Tip:** When editing a custom control, press **Run Event** to run the currently selected event. This can help you diagnose problems in a custom control.

1. Click **Navigation Menu > Custom Control > Editor**.



2. Click a **Bank X** list item to select the bank that the custom control you want to edit is on.
3. Click the custom control that you want to edit.
4. Click the event that you want to edit or insert an event before.

**Note:** The name of a custom control is highlighted in red if it contains events that are no longer supported. The unsupported events in the custom control are also highlighted in red.

Refer to [Custom Control Events](#) on page 160 for information on available events.

5. Edit the custom control or event.
  - **Append (Record)** — start inserting events to the end of the custom control.
  - **Append** — insert a new event at the end of the custom control.
  - **Copy** — copy the entire custom control.
  - **Delete** — delete the entire custom control.
  - **Delete Event** — delete the currently selected event.
  - **Edit Event** — edit the parameters of the currently selected event.
  - **Insert (Record)** — start insert events before the currently selected event.
  - **Insert** — insert a new event before the currently selected event.
  - **Record** — start recording a new custom control over the existing one.
  - **Replace** — replace the currently selected event with the new event.
  - **Run Event** — run the currently selected event.

## Custom Control Pause Mode

The switcher can be set so that each command is automatically separated from the previous

command by a pause equal to the real-time delay between events as you enter them.

When you are entering events into the custom control, the length of time between you entering the events is recorded as a pause between the events. This allows you to perform a set of actions as you normally would and have the custom control play those events back with the same pauses and 'rhythm' that you would normally have.

### To Set the CC Pause Mode

The CC Pause Mode must be set before recording a custom control and does now change how a custom control plays out.

1. Click **Navigation Menu > Configuration > System > Custom Controls**.



2. Click a **Pause Mode** button to select how the switcher inserts pauses into a custom control.
  - **Manual Pause** — no pauses are added. You must manually add pauses to the custom control.
  - **Record Pause** — pauses are entered automatically as you enter events. For example, if you pause for 30 seconds between selecting a key and performing a transition, a 30 second pause is inserted between those events in the custom control.

## Running a Custom Control

Once a custom control has been programmed, you can run that custom control by pressing the button that the custom control was recorded to.

### Keep the following in mind:

Keep the following in mind when running custom controls:

- A custom control will continue to run until it reaches a hold event, is stopped by another custom control, you edit a custom control, or the custom control reaches the end.
- When a custom control is running, the button on the custom control bus is red, a red border

is applied to the custom control on the Shot Box page in DashBoard, and the word Running is shown below the name.

- When a custom control is held (at a Hold event), the button on the custom control bus flashes white, a grey border is applied to the custom control button on the Shot Box page in DashBoard, and the word Held is shown below the name.
- You can run multiple custom controls at the same time. The number of running custom controls is shown on the display when in custom control mode.
- You can stop a running custom control by pressing the red custom control button on the custom control bank.
- You can stop all running custom controls by selecting a custom control with no events recorded to it.
- A maximum of 128 custom controls can be run at the same time.
- The name of a custom control is highlighted in red if it contains events that are no longer supported. The unsupported events in the custom control are also highlighted in red.

### To Run a Custom Control

Once a custom control has been recorded, you can run that custom control at any time.

1. Click **Navigation Menu > Custom Control > Shot Box**.



*Tip: You can also run a custom control directly from the control panel.*

*Tip: The number of custom controls that are currently running is shown at the bottom of the page.*

2. Click **Bank X** to select the bank that the custom control you want to run is on.
3. Click a custom control button to run that specific custom control. The custom control starts to play immediately.

## Custom Control Names and Mnemonics

Each custom control can be given a unique name and mnemonic color. The name and color are shown on the custom control button.

### To Name a Custom Control

The procedure to name or rename a custom control is the same.

*Tip: You can also name a custom control and bank from the Editor page.*

*Tip: Refer to General Settings on page 128 for information setting how the custom control names are shown on the control panel mnemonics.*

1. Click **Navigation Menu > Custom Control > CC Mnemonics**.



2. Click **Bank X** to select the bank that the custom control you want to name is on.
3. Select how you want the mnemonics on each panel row to display the mnemonics for custom controls.
  - **Off** — the mnemonics don't change when the row is assigned to a custom control bank.
  - **Split** — the mnemonics are split (top to cc name and bottom to bus sources) when the row is assigned to a custom control bank.
  - **Full** — the mnemonics are show only the names of the custom controls when the row is assigned to a custom control bank.
4. Click the custom control that you want to name.

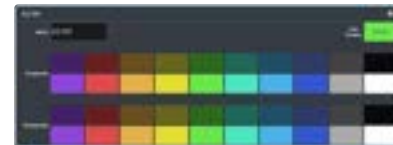

Setting	Description
<b>Name</b>	Enter a new name for the selected custom control.

Setting	Description
<b>Foreground</b>	Click a <b>Foreground</b> button to select the color you want to apply to the text on the mnemonic.
<b>Background</b>	Click a <b>Background</b> button to select the color you want to apply to the background on the mnemonic.



6. Click **Copy**.

## Deleting a Custom Control

Any custom control on the switcher can be deleted to remove unused customs to free up space for new custom controls.

### To Delete a Custom Control

Deleting a custom control from the switcher.

There is no undo for this delete function.

1. Click **Navigation Menu > Custom Control > Editor**.
2. Click **Bank X** to select the bank that the custom control you want to delete is on.
3. Click the custom control button that you want to delete.
4. Click **Delete**.
5. Click **Delete** to delete the custom control.

## Copying and Pasting a Custom Control

The contents, or events, of a custom control can be copied from one custom control and pasted to another. Along with the events, the name and mnemonic settings are also copied.

### To Copy and Paste a Custom Control

Copy the contents of a custom control from one button to another.

1. Click **Navigation Menu > Custom Control > Editor**.
2. Click **Bank X** to select the bank that the custom control you want to copy is on.
3. Click the custom control that you want to copy.
4. Click **Copy**.
5. Select the custom control that you want to paste into.

# Sequencer

The Sequencer allows you to create a playlist of custom control events.

The switcher supports 5 Sequencers, each with an independent rundown of events. The Sequencer uses sequences to store the rundown of events. These sequence files can be loaded into one or multiple Sequencers.

*Tip: You can link multiple Sequencers together so that as you advance through one, the other Sequencers will advance.*

## Keep the following in mind:

Keep the following in mind when working with a Sequencer:

- Unlike a Custom Control, a Sequence only runs a single event at a time. You must advance to the next event in the sequence to run that event.
- If you run a Play CC event in a sequence, the Sequencer does not indicate when the CC event has completed.
- Only a subset of CC events can be run directly in the a sequence. You can use the Play CC event to run a custom control that contains any other events.
- If you edit a sequence that is already loaded into a Sequencer, you must **Reload** the sequence to update the event in the Sequencer.
- There is only one linked group. When **Linked** is toggled on for a Sequencer it is tied to all other Sequencers with **Linked** turned on.
- Linking only affects the operation of the **Next** button.
- Memories cannot be used to load a sequence into a Sequencer.

## Creating/Editing Sequences

When you create a sequence, you record a series of events and special functions that are played back as you step through the sequence. The process for creating a new sequence and editing an existing one are the same, except when editing you have the option to insert events at different points in the existing sequence.

*Tip: Remember that sequences run one event at a time. Use the Memory Recall or Transition Action events to perform complex actions.*

## To Create/Edit a Sequence

Editing a sequence is similar to creating or editing a custom control. A series of events are added to a list in the order you want the events to be run.

1. Click **Navigation Menu > Live Assist > Sequencer > Editor**.



2. Click a **Sequence** list item to select the sequence that you want to create or edit. If the sequence already has events, the name of the sequence is shown in the list and events are shown on the right.

*Tip: You can rename the sequence by entering a new name in the field at the top.*

3. Click **Modify Event List**.
4. Click the **Create/Edit Event** buttons to navigate to and select the event you want to add to the sequence. Refer to [Custom Control Events](#) on page 160 for information on the events.

*Tip: The Sequencer only supports a subset of the possible CC events. If you want to run a custom control event that is not listed for the sequencer, you can create a CC with that event in it and then use the Play CC event in the sequence to run that custom control.*

*Tip: If you want to edit an existing event, select the event you want to edit and click **Edit Event**.*

5. Add or edit an event in the sequence.
  - **Append** — insert the new event at the end of the sequence.
  - **Delete Event** — delete the currently selected event.
  - **Insert** — insert the new event before the currently selected event.
  - **Replace** — replace the currently selected even with the new event.
  - **Run Event** — run only the currently selected event.
6. Click **Done** when you are finished editing the sequence.

## Loading and Running a Sequence

Once a sequence has been created, you can load that sequence into a Sequencer and run each event.

### To Load a Sequence

A sequence must be loaded into the Sequencer before it can be run.

1. Click **Navigation Menu > Live Assist > Sequencer > Run.**



2. Click **Load** on the Sequencer you want to load a sequence into.



3. Click the **SEQ** button for the sequence you want to load.

**Tip:** Click **Clear** to unload the sequence from the Sequencer.

**Tip:** Click **Reload** to load the sequence into the Sequencer again. This can be useful if you have edited the sequence.

### To Run a Sequence

A sequence is run one event at a time. Events can be skipped over by selecting a different event in the sequence as the next event.

1. Click **Navigation Menu > Live Assist > Sequencer > Run.**



2. Use the **Up**, **Down**, and **Next** buttons to run through the sequence.



#	Function
1	The currently loaded sequence. This uses the mnemonic name and color.
2	Multiple Sequencers can be linked together. This only affects the <b>Next</b> button and allows clicking <b>Next</b> on any of the linked Sequencers to advance all the linked Sequencers. There is only one linked group.
3	The <b>Reload</b> , <b>Clear</b> , and <b>Load</b> buttons allow you to populate or clear the Sequencer. <ul style="list-style-type: none"> <li>• <b>Load</b> — load a different sequence into the Sequencer.</li> <li>• <b>Clear</b> — unload the current sequence from the Sequencer.</li> <li>• <b>Reload</b> — reload or update the current sequence in the Sequencer.</li> </ul>
4	The red highlight shows the last run (current) sequence event.
5	The green highlight shows the next event to be run. Click on a different event, or use the <b>Up</b> or <b>Down</b> buttons to select a different event to be run next.
6	The <b>Up</b> and <b>Down</b> buttons move the green (run next) highlight up and down in the sequence.
7	The <b>Next</b> button runs the event that is currently highlighted in green.

## Sequence Names and Mnemonics

Each sequence can be given a unique name and mnemonic color. The name and color are shown on the Sequencer.

### To Name a Sequence

**Tip:** You can also name a sequence from the **Editor** page.

1. Click **Navigation Menu > Live Assist > Sequencer > Sequencer Mnemonics.**

2. Click the sequence that you want to name.

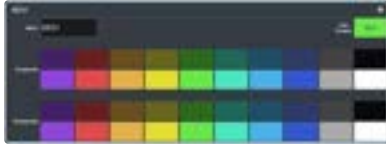

Setting	Description
<b>Name</b>	Enter a new name for the selected sequence.
<b>Foreground</b>	Click a <b>Foreground</b> button to select the color you want to apply to the text on the mnemonic.
<b>Background</b>	Click a <b>Background</b> button to select the color you want to apply to the background on the mnemonic.

## Deleting a Sequence

Any sequence can be deleted to remove unused sequences to free up space for new sequences.

### To Delete a Sequence

There is no undo for this delete function.

1. Click **Navigation Menu > Live Assist > Sequencer > Editor**.
2. Click the sequence that you want to delete.
3. Click **Delete**.
4. Click **Delete** to delete the sequence.

## Copying and Pasting a Sequence

The contents, or events, of a sequence can be copied from one sequence and pasted to another. Along with the events, the name and mnemonic settings are also copied.

### To Copy and Paste a Sequence

1. Click **Navigation Menu > Live Assist > Sequencer > Editor**.
2. Click the sequence that you want to copy.
3. Click **Copy**.
4. Select the sequence that you want to paste into.

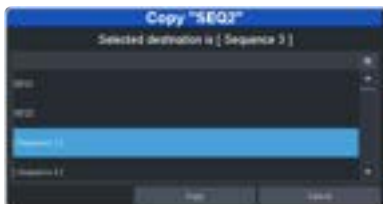

5. Click **Copy**.



# UltraScene

UltraScene provides a simplified interface for creating a show with multiple key layers and basic transitions.

UltraScene consists of 4 scenes that share 8 layers in 4 layer pairs. Layers can only be added in pairs, so a scene can have 2, 4, 6, or 8 layers. Each layer is set up like a keyer with a video source, alpha, and key type. Each layer can also be turned on or off to cut the video source on or off-air. A background source is also available over which the layers are keyed.

## Keep the following in mind:

Keep the following in mind when working with UltraScene:

- A scene can be used as a source on an ME, MiniME™, Canvas, or aux, or assigned directly to an output.
- A layer pair can only be assigned to a single scene at a time. If you assign all 4 layer pairs to a scene there are no layer pairs available for the other scenes.
- You cannot store or recall a single scene. All scenes are stored and recalled together.
- Layers can be included in switcher memories. The memory stores and recalls the contents of the layer, but not the number or position of layers in the scene.
- DVE resources used for layers are taken from the switcher pool of DVE resources. If there are no free DVE resources, the switcher will take the DVE from another location on the switcher. DVE resources are taken from scenes last.
- Layers can only be turned on or off from the UltraScene menu one at a time.
- You can change the order of the layers by dragging and dropping from one layer position to another. This does not change the layer position, but moves the contents of that layer to a new layer position. As you drag the layer a blue line shows the location where the layer can be inserted.
- As you drag a layer from a lower layer position to a higher position, all the layers below the higher position shift down to fill the layer position of the layer you are moving.

- If you remove all the layers from a scene the output of that scene goes black and does not show the background source.
- Scenes can only use physical inputs, mattes, Media-Store, clip player, chroma keys, and aux buses as sources.
- If an aux is used as a source in a scene the aux is restricted to physical input, follows, Media-Store, clip player, matte, or chroma key sources.
- Scenes are not retained with a power cycle.
- The background of the scene must be black if the scene is selected on a key bus. If you want to have a background for the scene, set up layer 1 with the background video as a self or auto key and set the **Keyer Mode** to **Full**.

## Scene Overview

A scene is made up of layers that are located in layer positions. These positions set the order of the video elements on top of the background. A layer position that is higher (larger number) than another layer position will appear visually on top of the layer positions below it. Layers can be moved or copied from layer position to layer position.



1. **Add Layer Pair** — Layers are added to a scene in pairs started with layer positions 1 and 2. As you add layer pairs to a scene, the counter to the left of the **Add Layer Pair** button indicates the number of layer pairs used in the scene and the number of resources remaining in the pool. If you use all the layer pairs in one scene there are no resources available for the other scenes.
2. **Layer Pair** — A layer pair consists of two layer positions. Each layer position contains a single layer. The layer contains the source and appearance of the video that you want to have in your scene and the layer position sets the position of the layer video on top or underneath the other layers.
3. **Layer Position** — The layer position sets whether a layer is on top or underneath other layers. The layer 1 position is always

the lowest position with layer 2 position appearing over layer 1, and layer 3 appearing over layers 1 and 2. A layer can be dragged from one layer position to another or copied and pasted into several layer positions. Drag and drop places a layer between two existing layers and paste over the existing layer in that layer position. The position of a layer only applies to layers that on-air at the same time. If you do not intend to have multiple layers on-air at the same time, or the video of the layers will not cover each other, the order of the layers does not matter.

*Tip: If you drag a layer from a lower layer position to a higher layer position, the layers below the point you want to insert the layer shift down a layer position to fill the empty layer position left by the layer you dragged. A blue line shows the position that the layer can be inserted in. For example, if you drag the layer from the Layer 1 position to between the Layer 3 and 4 positions, the layer in the layer 2 position will shift down to the layer 1 position, layer 3 shifts to the layer 2 position, and the layer you dragged is inserted into the layer 3 position.*

4. **Layer** — The layer contains the video source that you want to appear in the scene. The position that the layer is placed determines if it appears on top or underneath the other layers. For each layer you can set whether it is on or off-air, the video fill and alpha, and the type of keying you want to use. These settings move with the layer as you drag or copy it to a new layer position.
5. **On/Off** — Select whether the layer is on-air (**On**) or off-air (**Off**). Toggle the button to cut the layer on or off-air. The on-air setting is moved or copied with the layer.
6. **Layer Settings** — Select the video fill (**Fill Source**) and alpha (**Alpha Source**) for the key type (last button) you are assigning to the layer. When you click the key type button you can adjust the key type parameters. Refer to [Keying](#) on page 36 for information on setting up the different key types.
7. **Layer Copy/Paste** — Copy and paste one layer over another layer. You cannot add a layer position or layer pair with a copy and paste. A copy does not include the on/off status of the layer.
8. **Remove** — Remove a layer in the layer pair to return the resources to the pool. This does not remove the layer positions, but removes the layers from those positions and returns

the layer pair resources to the pool. Like dragging and dropping, if you remove the layers from a lower layer position, the layer above that position drop down to fill the empty layer position. Layer positions 7 and 8 are always the last to be added and first to be removed.

9. **Background** — Apply a video source as the background for the scene. This is the video source that the layers appear over top of. If the scene is used as a key source the background is ignored.

### Keep the following in mind:

Keep the following in mind when working with scenes:

- A layer is cut on or off-air with the On/Off button. Scenes do not support other transition types.
- An UltraScene recall does not have a transition effect like the Effects Dissolve in switcher memories.

### To Create a Scene

1. Click **Navigation Menu > Live Assist > UltraScene > Scene X** for the scene you want to use.



2. Click the **Add Layer Pair** button to add as many layer pairs as you need for your show.

*Tip: If you only need an odd number of layers you will still need to add an even number of layers. For example, if you only need 3 layers, you will still need to add 2 layer pairs resulting in 4 layers.*



3. Click the **Video Source** button for the layer you want to set up and select the source you want to use for the layer. If you want to use a chroma keyer, select the CK you want to use and click **Alpha/Chroma Key Source** to

select the video source you want to chroma key.



4. Click the **Type** button and select the type of keying you want to use for the layer. Layer types are set up in same way at key types. Refer to [Keying](#) on page 36 for information on setting up different key types.



**Tip:** If **PaneLINK** is active, the 3-knob menu will jump to the menus for the layer you are setting up.

5. Click the **On/Off** button to select whether the layer is on-air (**On**) or off-air (**Off**).
6. Set up the remaining layers as required.

**Tip:** If you want to change the order of the layers, click and hold on the name of the layer position (**Layer 1** for example) and drag it to the new position you want it to be and release. The new position is always between two existing layers or at the top or bottom. When you move the layer the other layers will shift to fill in the gap.

**Tip:** You can copy a layer and paste it over any other position on the same or a different scene.

7. Click the **Background** button and select the source you want to use on the background. If you are using the scene as a key you can leave the background as black (**BK**).

## UltraScene Memories

The UltraScene has an independent memory system that allows you to store and recall all the scenes, including layer assignments, video sources, and on-air status. This memory system is not tied to the switcher memory system that can also be used to store and recall the video assigned to each layer.

**Note:** There is no way to delete or clear an UltraScene memory.

### To Store an UltraScene

1. Set up the scenes as you want them to be recalled.
2. Click **Navigation Menu > Live Assist > UltraScene > Store**.



3. Click the **Store UltraScenes** button for the memory location you want to use.

### To Recall an UltraScene

1. Click **Navigation Menu > Live Assist > UltraScene > Recall**.



2. Click the **Recall UltraScenes** button for the UltraScene you want to recall.

## Naming an UltraScene Memory

The UltraScene mnemonics are used to identify the UltraScene memories. Individual scenes names and mnemonics must be set from the **Inputs** menu.

### To Name an UltraScene Memory

1. Click **Navigation Menu > Live Assist > UltraScene > UltraScene Mnemonics**



2. Click the **Mnemonics** button for the UltraScene memory you want to customize the name and mnemonic for.

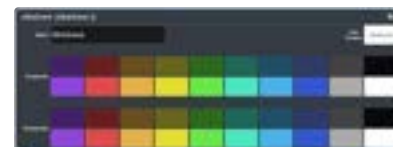

Setting	Description
<b>Name</b>	Enter a new name for the memory in the <b>Name</b> field.
<b>Foreground</b>	Click a <b>Foreground</b> button to select the color you want to apply to the text on the mnemonic.

---

Setting	Description
Background	Click a <b>Background</b> button to select the color you want to apply to the background on the mnemonic.

# Network Connections

The switcher requires a network connection for the DashBoard interface as well as any control panel you want to use.

DashBoard can be run on a remote computer, or from the TouchDrive control panel. The Carbonite Black control panels still require a separate DashBoard computer.

**Note:** Refer to the documentation that came with DashBoard or your control panel for setup information.

The switcher uses the following network ports:

- DashBoard (OGP) — 5253
- DashBoard (JSON) — 5254
- DashBoard Main — 5253 (5258 NAT)
- DashBoard Sat 1 — 5255 (5259 NAT)
- DashBoard Sat 2 — 5256 (5260 NAT)
- DashBoard SoftPanel — 5257 (5261 NAT)
- FTP — 21
- FTP (Graphite CPC) — 8821
- SFTP — 2222
- Panel (port on panel) — 3333
- RossTalk — 7788
- SLP — 427
- SSH — 22
- TFTP — 69
- TSL 3.1 (TCP, Carbonite) — 5727
- TSL 3.1 (TCP, Ultrix™) — 5727
- TSL 3.1 (UDP, Ultrix™) — 4490
- TSL 5.0 (TCP, Carbonite) — 5728
- TSL 5.0 (TCP, Ultrix™) — 5729
- TSL 5.0 (UDP, Ultrix™) — 4492
- Web Server 1 — 80
- Ultritouch — 5254
- SideShot-NG — 5255

## Network Setup

The frame comes from the factory set with a static IP address (192.168.0.123) but can be set to a different static IP address. You must connect to the frame from DashBoard to set a different IP address.

**Tip:** If you do not know the IP address of the frame, you can set DIP switch 1 on the frame to set the IP address to 192.168.0.123. The frame must be re-started for the new IP address to be applied. Remember to set the DIP switch back once you have set the new IP address.

## To Connect DashBoard to the Frame

DashBoard connects to the frame as the main panel, or as a satellite panel. Connecting as a main or satellite panel is selected by the port used to connect to on the frame. All DashBoard connections and physical panels that connect on the same port mirror each other.

**Note:** The frame supports a maximum of 20 DashBoard connections at any one time. If there are already the maximum number of connections to a frame you will not be able to connect to it.

You need the IP address of the frame to connect to it from DashBoard.

1. Click **File > New > TCP/IP DashBoard Connect or openGear Device**.

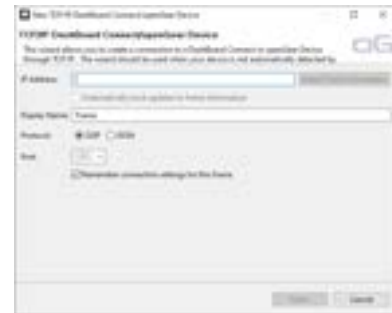

2. In the **IP Address** field, enter the IP address of the frame. The default IP address is 192.168.0.123.

**Note:** If you are connecting through a Network Address Translator (NAT), the **Detect Frame Information** button may return the wrong IP address. We recommend to not use this function.

3. In the **Display Name** field, enter the name you want to use to identify the frame in DashBoard. This should be a unique name for the frame you are setting up.
4. Select **OGP**.
5. In the **Port** field, enter the port you want to connect to on the frame. The port you connect to assigns the relationship the DashBoard connection has to the frame.

**Tip:** Multiple DashBoard connections can use the same port, but they will mirror each other. For example, you can connect a control panel and a separate DashBoard computer to the Main Panel port to give control from the panel and DashBoard.

- **Main Panel** — 5253 (5258 NAT)
- **Satellite 1** — 5255 (5259 NAT)
- **Satellite 2** — 5256 (5260 NAT)
- **Satellite 3/SoftPanel** — 5257 (5261 NAT)

*Tip:* Refer to [MultiPanel](#) on page 143 for information on setting up a MultiPanel system.

6. Click **Finish**.  
The frame appears in the **Tree View**.

### To Change the IP Address

Change the IP address of the frame from DashBoard.

1. Click **Navigation Menu > Configuration > Network**.



2. Enter a name in the **Switcher Name** field. This is the name that appears in the tree view in DashBoard.
3. Click an **Automatic Discovery** button to have the switcher automatically discoverable by DashBoard (**On**), or not (**Off**). Automatic Discovery allows you to automatically find this device from any DashBoard running on your subnet.
4. Click **Edit**.



5. Enter the IP address (**IP Address**), subnet mask (**Subnet Mask**), and gateway (**Gateway**) you want to use.
6. Click **Update**.

## Ross Platform Manager Connections

Ross Platform Manager can store and load configurations onto your switcher remotely. This allows for a centralized management of system configurations.

A Ross Platform Manager server can connect to the switcher over ethernet to download the working set or upload a new working set over FTP. An uploaded working set is immediately applied to the switcher when it is detected.

Refer to the Ross Platform Manager documentation for more information on orchestration.

## FTP Connection

You can create a File Transfer Protocol (FTP) connection from a computer to your switcher. You can use the FTP connection to copy still images and animations to and from your switcher as well as copy Edit Decision List (EDL) files from your switcher.

The procedure for creating an FTP connection from a computer varies between operating systems and client software. Consult with the documentation that came with your computer for assistance with creating an FTP connection.

*Note:* The FTP connection to the frame can be disabled by setting **FTP** (Click **Navigation Menu > Configuration > System > Global**) to **Disable**. The switcher must be re-started for the change to be applied.

*Tip:* The FTP connection can be used to copy media items onto the USB that is installed in the switcher.

### To Create an FTP Connection

This procedure applies to Microsoft® Windows® 7 and above.

*Note:* FTP must be **Enabled** (Click **Navigation Menu > Configuration > System > Global**) to connect to the frame over FTP.

1. On your computer launch Windows Explorer.
2. In the address bar, type `ftp://IP Address of your switcher`.  
You are prompted for a username and password.
3. Type the user name for the application you are creating an FTP connection for. Each application has specific requirements. The switcher will set these requirements automatically based on the username.
  - `xpression` – used when creating a connection from a Ross® XPression Motion Graphics System directly to the Media-Store channels on the switcher, as well as any USB drive installed in the switcher
  - `liveedl` – used to create a connection to the LiveEDL folder on the switcher to download an edit decision list file from the switcher
  - `user` – used to create a connection to the general storage folders on the switcher, as well as any USB drive installed in the switcher



**Important:** Do not copy a clip to the USB while a clip is playing. Copying a clip to the USB while the Clip Player is playing a clip can cause the clip to stutter or stop.

- rpm — used by Ross Platform Manager to manage the configuration of the switcher.
4. Enter the password password

## Video Reference

The flexible reference system in the switcher allows you to use an Interlaced video format as the reference to operate the switcher in a video format of the same frequency. Choosing a progressive video format as a reference limits you to operating the switcher only in that same video format and frequency. For example, if you have a 1080i 59.94Hz input reference you can operate the switcher in 720p 59.94Hz, but not 1080i 50Hz. However, if you have a 720p 59.94Hz input reference, you can only operate the switcher in 720p 59.94Hz.

### Supported Reference Formats

The switcher supports a number of reference modes for both internal and external reference signals. References to 1080p 59.94Hz (A) and 1080p 50Hz (A) refer to 1080p Level A only. UHD-QSD is not supported at this time.

Switcher Format	Required Reference
<b>SD Formats</b>	
480i/480i 16:9	480i
	1080i 59.94Hz
576i/576i 16:9	576i
	1080i 50Hz
<b>HD Formats</b>	
720p 50Hz	576i
	720p 50Hz
	1080i 50Hz
720p 59.94Hz	480i
	720p 59.94Hz
	1080i 59.94Hz
1080i 50Hz	576i
	1080i 50Hz
1080i 59.94Hz	480i
	1080i 59.94Hz
1080pSF 23.98Hz	1080pSF 23.98Hz
1080pSF 24Hz	1080pSF 24Hz
1080pSF 25Hz	576i
	1080pSF 25Hz
1080pSF 29.97Hz	480i
	1080pSF 29.97Hz

Switcher Format	Required Reference
1080pSF 30Hz	1080pSF 30Hz
1080p 23.98Hz	1080p 23.98Hz
1080p 24Hz	1080p 24Hz
1080p 25Hz	576i
	1080i 50Hz
1080p 29.97Hz	480i
	1080i 59.94Hz
1080p 30Hz	1080p 30Hz
1080p 50Hz	576i
	1080i 50Hz
	720p 50Hz
1080p 59.94Hz	480i
	720p 59.94Hz
	1080i 59.94Hz
1080p 60Hz	720p 60Hz
	1080i 60Hz
<b>UHD Formats</b>	
UHDTV1 23.98Hz	1080p 23.98Hz
UHDTV1 24Hz	1080p 24Hz
UHDTV1 25Hz	1080p 25Hz
UHDTV1 29.97Hz	1080p 29.97Hz
UHDTV1 30Hz	1080p 30Hz
	720p 50Hz
UHDTV1 50Hz	1080i 50Hz
	720p 50Hz
UHDTV1 59.94Hz	720p 59.94Hz
	1080i 59.94Hz
UHDTV1 60Hz	720p 60Hz
	1080i 60Hz

The switcher allows you to use any interlaced video format to operate the switcher in any format of the same frequency; however, the use of 480i or 576i (Composite Sync) reference signals for High Definition (720p, 1080i, or 1080p) video modes is not recommended.

The use of composite sync reference formats is recommended for Standard Definition video modes only, and provides stable outputs with jitter performance in compliance with SMPTE-259M specifications.



## Switcher Modes

The switcher can operate in either SD, HD, or UHDTV1 based modes with additional modes for audio sample rate conversion support and the number of keyers per ME. The video formats that the switcher can operate in are restricted to the mode the switcher is set to. If the switcher is in SD mode, only SD video formats are available. If the switcher is operating in HD mode, only HD video formats are available.

Any valid reference signal can be used for all modes.

**Note:** The 6 key modes reduces the maximum number of MEs to 2.

### To Set the Switcher Mode

Set the type of video formats that you want the switcher to operate in. This also selects the features and resources that are available on your switcher.

1. Click **Navigation Menu > Configuration > System > Global**.



2. Click the **Switcher Mode** button for the mode you want the switcher to operate in.

Mode	Format	Keyers/ME	MEs (max)	FSFCs (max)	SRC	Output Rates
SD 4 Key	SD	4	3	Yes	No	No
HD 4 Key	HD	4	3	Yes	No	No
HD SRC 4 Key	HD	4	3	Yes	Yes	No
HD ROT 4 Key	HD	4	3	12 max	No	3
HD 6 Key	HD	6	2	Yes	No	No
HD SRC 6 Key	HD	6	2	Yes	Yes	No
HD ROT 6 Key	HD	6	2	12 max	No	3
UHD	UHD	4	2	Yes	Yes	No

The switcher will restart in the new mode, but needs to be rebooted for all the changes to be implemented.

3. Wait for the DashBoard pages to come back up. This may take a few minutes.
4. Power cycle the frame by switching the power button **Off** and then **On** again.  
The switcher will come up in the new mode.

### Switcher Mode Video Formats

The switcher is restricted to specific video formats when operating in each Switcher Mode.

	SD Modes	HD Modes	UHD Modes
480i	✓		
576i	✓		
720p 50Hz		✓	
720p 59.94Hz		✓	
1080i 50Hz		✓	
1080i 59.94Hz		✓	
1080pSF 23.98Hz		✓	
1080pSF 24Hz		✓	
1080pSF 25Hz		✓	
1080pSF 29.97Hz		✓	
1080pSF 30Hz		✓	
1080p 23.98Hz		✓	
1080p 24Hz		✓	
1080p 25Hz		✓	
1080p 29.97Hz		✓	
1080p 30Hz		✓	
1080p 50Hz		✓	
1080p 59.94Hz		✓	
1080p 60Hz		✓	
UHDTV1 23.98Hz			✓
UHDTV1 24Hz			✓
UHDTV1 25Hz			✓
UHDTV1 29.97Hz			✓
UHDTV1 30Hz			✓
UHDTV1 50Hz			✓
UHDTV1 59.94Hz			✓
UHDTV1 60Hz			✓

## Switcher Mode Restrictions

When the switcher is operating in a UHDTV1 video format, the number of available resources is reduced to provide the additional processing power required for UHDTV1 production. The following table provides a quick overview of how the resources are re-allocated.

**Note:** Values represent maximum resources with all options installed.

**Table 2: Switcher Mode Restrictions**

	SD 4 Key	HD 4 Key	HD SRC 4 Key	HD ROT 4 Key	HD 6 Key	HD SRC 6 Key	HD ROT 6 Key	UHD	
MEs (Max) <sup>2</sup>	3			2					
MiniME™ Engines	4							2	
Keyers per ME (+Trans)	4			6					4
Canvas Generators	2 <sup>1</sup>							1 <sup>1</sup>	
Video Processor MultiViewer (Max) <sup>2</sup>	2							1	
I/O MultiViewer (Max) <sup>2</sup>	2							1	
I/O Processor (Max) <sup>2</sup>	34		--	34		--	-- <sup>3</sup>		
Input FSFCs/Output FCs (Min)	-- <sup>3</sup>		-- <sup>6</sup>	-- <sup>3</sup>		-- <sup>6</sup>	2 <sup>4</sup>		
Input FSFCs (Max) <sup>2</sup>	-- <sup>3</sup>		12		-- <sup>3</sup>		12	7	
Frame Delay (Max Frames)	--	13						7	
Output FCs (Max) <sup>2</sup>	-- <sup>3</sup>		2 <sup>5</sup>	-- <sup>6</sup>	-- <sup>3</sup>		-- <sup>6</sup>	4	
Proc Amp/Color Correctors (Max) <sup>2</sup>	-- <sup>3</sup>							7	
HDR Support	No	Yes	Yes	Yes	Yes	Yes	Yes	Yes	
WCG Support	No	Yes	Yes	Yes	Yes	Yes	Yes	Yes	
2D DVE Channels Switcher Wide	8							4	
Output Rotators	--		3		--		3	--	

	SD 4 Key	HD 4 Key	HD SRC 4 Key	HD ROT 4 Key	HD 6 Key	HD SRC 6 Key	HD ROT 6 Key	UHD
Chroma Keys (floating)	4							2
Media-Store Channels (Video + Alpha)	4							2
SDI Video Inputs	24							18
SDI Video Outputs	14							10

### Notes:

<sup>1</sup> Each Canvas consumes MiniME™ engines to generate the output. The number of Canvas outputs that are available depends on the number of MiniME™ engines that are available.

<sup>2</sup> Software options are required to be installed to activate the maximum number of resources.

<sup>3</sup> In SD or HD, the total number of color correctors, input FSFCs, and output FCs is shared. In UHDTV1 there are dedicated color corrector, input FSFC, and output FC resources.

<sup>4</sup> There are 2 FSFCs that are shared between inputs and outputs.

<sup>5</sup> In the HD SRC 4 Key mode, only outputs 5 and 6 support FC.

<sup>6</sup> In the ROT (Rotation) modes, there are only 12 inputs FSFCs.

## Reference and Video Mode Setup

The switcher supports both internal and external references. An external reference is provided by an external device to the switcher through the **REF IN** BNC on the frame. An internal reference is generated by the switcher and can be fed out to other devices.

The switcher automatically detects the reference signal and only shows the video modes that you can operate the switcher in that are supported for that reference format.

### To Set a Video Mode

The Vid Mode is the video format that the switcher is operating in.

If you are using an external reference, ensure that a proper reference is connected to the **REF IN** input BNC on the frame.

**Note:** You must use an interlaced reference source to have the switcher operate in an interlaced reference format if you are using an external reference.

**Note:** For information on Dynamic Range and Color Gamut conversion, refer to [High Dynamic Range \(HDR\) and Wide Color Gamut \(WCG\) Conversion](#) on page 125.

1. Click **Navigation Menu > Configuration > Reference**.



**Note:** Extra setting may be shown on the menu if you are operating in a UHDTV1 mode.

2. Click the **Video Mode** button and select the video format you want to use.

The available video modes depends on the reference format coming into the switcher.

3. Click the **Reference Source** button and select an **Internal** or **External** reference source.

## Output Reference Synchronizers

The output reference synchronizers allow you to have the switcher output a reference signal that other devices, such as cameras and video servers, can lock to.

**Note:** Different applications require different output reference formats and delay settings. Consult a facility engineer for assistance in configuring these settings.

### To Set Up an Output Reference Sync

The reference output allows the switcher to provide a reference signal to other upstream or downstream devices. If the switcher is using internal reference, this reference signal can be sent to other devices so that all your equipment is synced to the same reference.

1. Click **Navigation Menu > Configuration > Reference**.



2. Click on the **Reference Output X** button for the reference output BNC that you want to set up.
3. Click on the reference format you want to output from the switcher.

The available output reference formats depend on the video format that the switcher is operating in. You must be in a 50Hz video format for PAL and a 59.94Hz video format for NTSC.

4. Select the type of delay you want to apply to the reference signal.



- **V** — vertical delay in lines
- **H** — horizontal delay in pixels
- **F** — frame delay in frames (NTSC/PAL only)

5. Click **Update**.
6. Click **Yes** to assign the output reference synchronizer.

## Switching Field (SD or HD Only)

The switching field is the field in an interlaced video format that the switcher uses to transition from one video source to another. An interlaced video format is made up of two fields, field 1 (odd lines) and field 2 (even lines).

**Note:** If you are running in a progressive video format, selecting an even or odd fields will cause the switcher to only allow transitions on every second frame.

### To Set the Switching Field

Set the field that transitions are performed on when operating in an SD or HD video format.

**Note:** If you are using a Frame Sync or Format Conversion (FSFC), transitions are locked to Field 1.

1. Click **Navigation Menu > Configuration > System > Global**.



2. Click a **Field Dominance** button to select which field video transitions occur on.
  - **Field 1** — transitions occur on the odd field
  - **Field 2** — transitions occur on the even field
  - **Both** — transitions occur on the current field, either even or odd

# Video Inputs

External video sources come into the switcher through the input HD-BNCs and internal sources are generated internally. Depending on how you want to use these video sources, or where they come from, you may want the switcher to pair them together, or associate an external device with them. Pairing two video sources together is usually used for an auto select key where an external device, such as a character generator, outputs both a key video and key alpha. Associating a video source with an external device allows special control over that device to become active when you select the source on a bus.

## UHDTV1 Inputs

The switcher can accept UHDTV1 inputs in Quad-Link 3Gb/s UHD-2SI and UHD-QSD, or Single-Link 12Gb/s UHD-2SI. Different inputs consume a different number of BNCs, depending on the format.

**Note:** Only inputs 3-6 and 8-11 can accept Quad-Link 3Gb/s UHD-2SI or UHD-QSD video signals. Only inputs 3 and 8 of these groups can accept Single-Link 12Gb/s UHD-2SI.

**Tip:** Single-Link 720p, 1080i and 1080p video signals can be up-converted on some inputs.

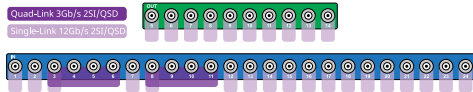

Figure 8: UHD Input/Output

## Video Input Setup

Video inputs are separated into external sources and internal sources. The external sources are the video inputs coming in on the HD-BNC at the back of the frame and the internal sources are generated internally either from re-entries or follows, or from media generators.

### To Set up an External Video Input

External sources come into the switcher from other devices, such as cameras, video servers, or character generators.

Click **Navigation Menu > Configuration > Inputs > External**

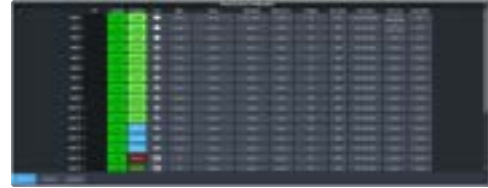

The physical inputs are listed along the side and the various settings are listed across the top. Click the setting button for the source you want to set up to view the available settings.

Setting	Description
<b>Text</b>	Apply a custom name to the source. Enter a new name for each input you want to identify differently. The name is used to identify the input on the panel mnemonics and well as on menus. If TSL id is associated with the input, the switcher will use the router mnemonic name over the internal one.
<b>Carbonite</b>	Set up the mnemonic appearance of the source for the control panel you are using. Refer to your control panel documentation for more information on setting up mnemonics.
<b>TouchDrive</b>	
<b>Icon</b>	
<b>Alpha</b>	Link an alpha video feed to the video. If the input is the video or fill for an auto key, click the <b>Alpha</b> button and select the video source you want to use as the alpha. Refer to <a href="#">To Set Up an Auto Key Association</a> on page 96 for information on setting up an auto key.
<b>Device</b>	Link an external device to a video input to allow remote control for that device.
<b>Audio Mixer</b>	Link an external audio mixer to a video input. Select the audio mixer and audio channels on the mixer that you want to associate with the video. Associating audio channels with video sources allows for Audio Follow Video (AFV) control from the switcher where the audio channel is brought up when the video it taken on-air.
<b>Mask Source</b>	Link a video mask to the video source. Much like an alpha, you can link a mask source to the video. The external mask source is used by the chroma keyer mask. Refer to <a href="#">To Mask a Chroma Key</a> for information on using an external mask.
<b>Configure</b>	Assign an FSFC or Delay to the input. Refer to <a href="#">Frame Sync and Format Conversion</a> on page 115 for information on FSFC setup.
<b>Dyn. Range</b>	Select the current dynamic range of the video signal on the input. This is the dynamic range that the video signal is being converted from. Refer to <a href="#">High Dynamic Range (HDR) and Wide Color Gamut (WCG) Conversion</a> on page 125 for more information.

Setting	Description
<b>Color Gamut</b>	Select the color gamut of the video signal on the input. This is the color gamut the video signal is being converted from. Refer to <a href="#">High Dynamic Range (HDR) and Wide Color Gamut (WCG) Conversion</a> on page 125 for more information.
<b>TSL</b>	Assign a TSL id to the input and set the tally state. Refer to <a href="#">To Assign a TSL ID to a Video Input</a> on page 94 for information on assigning a TSL id to an input.
<b>Panel Follow</b>	Select one of the custom panels to be shown on Live Assist when the source is selected. This can be used to have the Dashboard page for a camera control unit displayed when the camera source is selected. Refer to <a href="#">Custom Page Auto Follow</a> on page 97 for information on setting up custom panels.

### To Set up an Internal Video Input

Internal sources are generated inside the switcher, such as matte backgrounds, Media-Store channels, and ME re-entries.

Click **Navigation Menu > Configuration > Inputs > Internal**



The internal sources are listed along the side and the various settings are listed across the top. Click the setting button for the source you want to set up to view the available settings.

Setting	Description
<b>Text</b>	Apply a custom name to the source. Enter a new name for each input you want to identify differently. The name is used to identify the input on the panel mnemonics and well as on menus.
<b>Carbonite</b>	Set up the mnemonic appearance of the source for the control panel you are using. Refer to your control panel documentation for more information on setting up mnemonics.
<b>TouchDrive</b>	
<b>Icon</b>	
<b>Alpha</b>	Link an alpha video signal to the video. The Media-Store channels have dedicated alpha channels that cannot be changed. Refer to <a href="#">To Set Up an Auto Key Association</a> on page 96 for information on setting up an auto key.
<b>Device</b>	Link an external device to a video input to allow remote control for that device.

Setting	Description
<b>Audio Mixer</b>	Link an external audio mixer to a video input. Select the audio mixer and audio channels on the mixer that you want to associate with the video. Associating audio channels with video sources allows for Audio Follow Video (AFV) control from the switcher where the audio channel is brought up when the video is taken on-air.
<b>Panel Follow</b>	Select one of the custom panels to be shown on Live Assist when the source is selected. The pages for MediaManager are assigned to the Media-Store sources. Refer to <a href="#">Custom Page Auto Follow</a> on page 97 for information on setting up custom panels.

## Source Names

Each video source in the switcher can be given a unique name. These names can be customized for how they appear on the mnemonics by adjusting the size or the font and the background color.

*Note: If a TSL ID is assigned to a source, the switcher overwrites the source name on the MultiViewer and mnemonics with the TSL name. If there is no TSL name, or it has not been received yet, the source name is blank. For the labels on the MultiViewer, a combination of the TSL name and switcher source name are used. The new TSL name is passed from the switcher to any downstream TSL devices.*

### To Set Up a Source Name

Source names appear on mnemonics, menus, and on the MultiViewer.

*Note: Source names are restricted to eight characters in length.*

1. Click **Navigation Menu > Configuration > Inputs > External** if you are setting up a physical input, or **Internal** if you are setting up an internal input.
2. Enter a new name in the **Text** field for the video input that you want to name.

### To Assign a TSL ID to a Video Input

Pass router mnemonic names to the switcher with TSL ID 3.1 or 5 data.

The switcher accepts incoming TSL 3.1 data on TCP port 5727 and TSL 5 data on TCP port 5728.

1. Click **Navigation Menu > Configuration > Inputs > External**

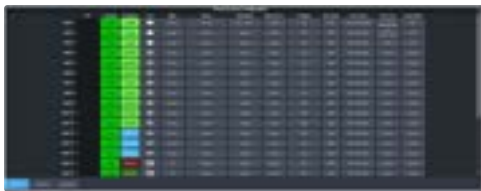

2. Click the **TSL** button for the input you want to assign a TSL ID to.



3. Click a **TSL Protocol** button to select the TSL protocol version the input is listening for.
  - **Off** — TSL is off for this input.
  - **3.1** — the selected input is listening for TSL 3.1 messages.
  - **5** — the selected input is listening for TSL 5 messages.
4. In the **TSL Address** field, enter the TSL ID that applies to the selected input.
5. Click the **TSL Tally Mode** button and select how the source is tallied and which mnemonic name is use.
  - **Name Only** — TSL tally information for the selected ID is ignored. TSL mnemonic source names are used.
  - **Name&Tally** — source tallied on the MultiViewer based on the TSL input. TSL mnemonic source names are used.
  - **Tally Only** — source tallied on the MultiViewer based on the TSL input. TSL mnemonic source names are not used.

**Note:** If a TSL ID is assigned to a source, the switcher overwrites the source name on the MultiViewer and mnemonics with the TSL name. If there is no TSL name, or it has not been received yet, the source name is blank. For the labels on the MultiViewer, a combination of the TSL name and switcher source name are used. The new TSL name is passed from the switcher to any downstream TSL devices.

## Mnemonics

The mnemonic displays on the control panel show the name of the video source and can be customized for font size, color, and in some cases icons can be added. The customization that is available depends on the control panel you are using.

**Note:** The SoftPanel uses the Carbonite settings.

## To Customize Mnemonics for TouchDrive

The TouchDrive control panels support RGB color mnemonics and icons.

1. Click **Navigation Menu > Configuration > Inputs > External** if you are setting up a physical input, or **Internal** if you are setting up an internal input.
2. Click the **TouchDrive** button for the source you want to customize the mnemonics for.

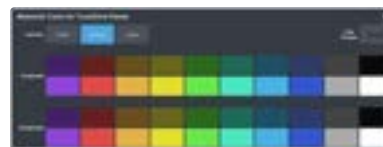

Setting	Description
<b>Font Size</b>	Click <b>Small</b> , <b>Medium</b> , or <b>Large</b> to select the size of the font used on the mnemonic display. The larger the font, the fewer characters that are visible on the mnemonic.
<b>Foreground</b>	Click a <b>Foreground</b> button to select the color you want to apply to the text and icon on the mnemonic.
<b>Background</b>	Click a <b>Background</b> button to select the color you want to apply to the background on the mnemonic.

3. Click the **Icon** button for the source you want to customize the mnemonics for and click the icon you want to use.



## To Customize Mnemonics for Carbonite Black

The Carbonite control panels support three-color mnemonics without icons.

1. Click **Navigation Menu > Configuration > Inputs > External** if you are setting up a physical input, or **Internal** if you are setting up an internal input.
2. Click the **Carbonite** button for the source you want to customize the mnemonics for.



Setting	Description
<b>Font Size</b>	Click <b>Small</b> , <b>Medium</b> , or <b>Large</b> to select the size of the font used on the mnemonic display. The larger the font, the fewer characters that are visible on the mnemonic.
<b>Color</b>	Click a <b>Color</b> button to select the color you want to apply to the mnemonic. The color is applied either to the background or the font, depending on the <b>Inverse</b> setting.
<b>Inverse</b>	Click an <b>Inverse</b> button to have the color applied to the background ( <b>No</b> ) or the text ( <b>Yes</b> ).

## Auto Key Setup

An auto key allows you to associate a key alpha with a key video source in the switcher. When the video source is selected as a keyer, the key alpha is automatically used.

**Note:** Some internal sources, like Media-Store, Chroma Key, MiniME™, and UltraScene outputs, are hard-coded to their alpha signals.

### To Set Up an Auto Key Association

As well as input sources, internally generated sources, such as media-stores and color backgrounds, can be set up as an auto key.

1. Click **Navigation Menu** > **Configuration** > **Inputs** > **External** if you are setting up a physical input, or **Internal** if you are setting up an internal input.
2. Click the **Alpha** button for the key video source that you want to assign an alpha to.

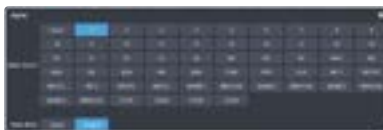

3. Click the **Alpha Source** button for the source that you want to assign to the key video.

**Tip:** Some internal sources have alpha signals hard coded to them and others do not support an alpha signal.

- **--none--** — no alpha
- **XX** — assign the source on the selected input as a key alpha

- **BK** — assign internal black as a key alpha
- **BG** — assign the matte generator as a key alpha
- **MX** — assign the video on Media-Store X as a key alpha
- **MXA** — assign the alpha on Media-Store X as a key alpha
- **PGM** — assign the main program output as the key alpha
- **PRV** — assign the main preview output as the key alpha
- **CLN** — assign the main clean feed output as the key alpha
- **MEX** — assign the program output of ME X as the key alpha
- **MEX PV** — assign the preview output of ME X as the key alpha
- **MEX CL** — assign the clean feed output of ME X as the key alpha
- **MiniMEX** — assign the output of MiniME™ X as the key alpha
- **MMXCmb** — assign the combined alpha of MiniME™ X as the key alpha
- **CKXA** — assign the alpha output of chroma key X as the key alpha

4. Click an **Alpha Mode** button to select the alpha mode for the key alpha.
  - **Linear** — switcher performs a multiplicative key. The key alpha cuts a hole based on the gradient values of the alpha. Shades of gray are translated into transparency levels, giving the key a soft edge. Unshaped key alphas can also be considered true linear alphas.
  - **Shaped** — switcher perform an additive key. With shaped keys, the key alpha cuts a hole based on the monochrome value of the alpha. Shades of gray are translated into either white or black, giving the key a hard edge. Shaped Key alphas are sometimes used with Character Generators to cut very precise holes for the fill.

## GPI Device Control

You can assign a GPI output to a video source for basic external device control. When a video source is taken on-air, the switcher can be set to trigger a GPI output, with a pre-delay. The external device can be set up to cue a clip, or



load a page when it receives the GPI input trigger.

**Note:** The Next Button Secondary Function must be set to GPO to be able to trigger a GPI output manually using the **NEXT** button on the control panel.

### Keep the following in mind:

Keep the following in mind when working with GPI output triggers:

- The **Roll Clip** must be set to **On** to trigger a GPI output with a transition.
- Edge triggered GPI outputs remain triggered for the configured duration.
- Level triggered GPI outputs toggle between high and low each time they are triggered.

### To Assign a GPI Output to a Video Source

Assign a GPI output to an external video source to trigger events on external devices.

1. Click **Navigation Menu > Configuration > Tally and GPIO** and click **External Tally** or **Internal Tally**, depending on the video source you want to apply the GPI to.



2. Click the **GPO** button for the video source that you want to assign a GPI output to. If you are using the GPI to control the device, the video source should be the video output coming from the device.
3. Click the GPI output that you want to assign to the video source.

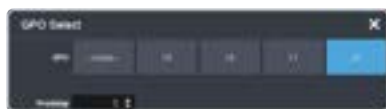

**Note:** You must have GPIs set as outputs to be able to assign them to the video source.

4. In the **Predelay** field, enter the pre-delay time, in frames, you want to use with the GPI output.

When you transition a video source with a GPI assigned to it, and the Roll Clip feature is active, the switcher triggers the GPI output, and then waits the pre-delay time before performing the transition. The length

of the pre-delay is usually the length of time your video server requires to start playing a clip or your character generator requires to load a page.

## Tallies Setup

Tallies are simple contact closure relays that the switcher uses to signal other devices, and users, that a particular video source is on-air. Typically, tallies are used to light a red light on a camera to show people that they are on-air and what camera they should be looking at.

**Note:** Tallies are tied to the On-Air setting for the bus the source is selected on. If the bus is not set to be tallied as on-air, the tallies for the sources selected on that bus do not trigger. Refer to [On-Air Setting](#) on page 104 for information on setting the on-air status.

### To Assign a Tally to a Video Source

Tallies are assigned to video sources and are triggered when that input is selected on a bus that is on-air or is going on-air.

1. Click **Navigation Menu > Configuration > Tally and GPIO** and click **External Tally** or **Internal Tally**, depending on the video source you want to apply the tally to.

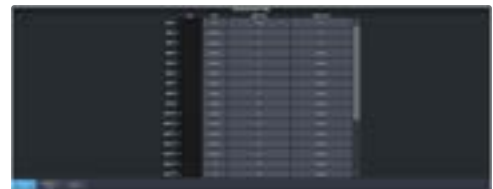

2. Click the **Tally On Air** or **Tally on Prv** button for the source you want to assign a tally to.
  - **Tally On Air** — tally the selected source when it is on-air.
  - **Tally On Prv** — tally the selected source when it is going to be taken on-air with the next transition.

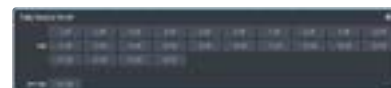

3. Click the **Tally** and/or **GPO Tally** buttons for the tallies you want to assign to the source.

**Tip:** You can assign multiple tallies to the same source, and you can assign the same tallies to multiple sources.

## Custom Page Auto Follow

DashBoard pages can be assigned to custom page buttons in Live Assist. These custom pages

can then be assigned to video inputs allowing Live Assist to auto follow to these pages when that video input is selected. For example, you can assign a custom page to the DashBoard page that controls a robotic camera. You can then set that custom page to follow the input from that camera. Whenever you select that camera as a source, Live Assist will jump to the custom page for that camera.

**Note:** PaneLink must be active in Live Assist for auto follow to function.

**Tip:** Press Click **Navigation Menu > Live Assist > Custom Views** to view the current custom view pages.

## To Assign a Page to a Custom Page Button

The custom page buttons on the Live Assist page can be assigned any custom page or node in DashBoard. This allows you to quickly access controls from another device on DashBoard from Live Assist on your current device.

1. Click **Navigation Menu > Configuration > System > Live Assist**.



2. Click on the **Address** drop-down list for the custom page button you want to assign to a page.
3. Select the connection or custom panel that you want to assign to the custom page button.
  - **All Connections** — expand the list and select the device and node that you want to assign to the custom page button. Some older DashBoard nodes from plug-ins may not display properly on the Live Assist buttons.

**Note:** Do not assign the Live Assist page to a custom page. A custom page will not display Live Assist from any switcher.

- **Open Panels** — expand the list and select the open custom panel you want to assign to the list. You must have the custom panel running on DashBoard for it to appear in the list.

**Tip:** Click **Clear** to remove the custom page and name assigned to that button.

4. Click on the name field for the custom page button you are assigning a page to and enter a descriptive name for the custom page. The name appears on the button in Live Assist.

## To Assign a Custom Page to Follow an Input

Assign a Live Assist custom page to follow a physical or internal video source.

1. Click **Navigation Menu > Configuration > Inputs > External** if you are setting up a physical input, or **Internal** if you are setting up an internal input.
2. Click the **Panel Follow** button for the input you want to assign a custom page to.



3. Click the custom page you want to assign to the input or click **none**.

## Substitution Table

A substitution table allows you to specify a different source that will be taken on a bus when a specific source is selected on that bus. The substitution table requires either a MultiScreen or ME follow to be set up between the buses to trigger the substitution.

The substitution table can be used with the ME follows feature to create multilingual production feeds. For example, you can have ME 2 follow ME 1 to simultaneously produce multiple feeds. When a source is selected on ME 1, the same source is selected on ME 2. With the substitution table you can have it that when camera 1 is selected on ME 1 the follow will select camera 1 on ME 2 but the substitution table substitutes camera 4 for camera 1 on ME 2. Refer to [ME Follows](#) on page 103 for information on setting up ME follows.

When working with a MultiScreen setup, the substitution tables allow you to take pre-tiled sources from a CG or video server and have the switcher treat them as a single source across multiple areas or buses. When the first tile is selected on MiniME™ 1, the substitution table also selects the second tile on MiniME™ 2.

### Keep the following in mind:

Keep the following in mind when working with substitution tables:

- When working with a MultiScreen, the bezel compensation and data doubling setting should be set up on the source generator.
- If you want to create a substitution for an auto-select key, you must set up a substitution for both the fill and the alpha.
- Selecting a crosspoint directly on a bus that has a substitution set up for it overrides the substitution. The substitution continues when a new source is selected on the leading bus.

### To Set Up a Pre-Tiled Source

The substitution table is a single table that allows you to specify a different source that should be taken when a specific source is selected on a bus. The substitution table requires either a Canvas or ME follow to be set up between the buses to trigger the substitution.

*Tip: When you select the Source on the ME/Bus, the Substitution source is taken instead.*

1. Click **Navigation Menu > Configuration > Inputs > Substitutional**.



2. Click **New ME Sub** or **New Bus Sub** to select the type of substitution table you want to set up.
  - **New ME Sub** — create a substitution on an ME or MiniME™.
  - **New Bus Sub** — create a substitution on a key bus of an ME or MiniME™, or an aux bus.
3. Click the **Source** button and select the source that you want to substitute with another source.
4. Click the **ME** or **Bus** button and select the area that you want the substitution to occur on.
5. Click the **Substitution** button and select source you want to substitute for the selected one. Repeat for any addition substitutions you want to create.
6. Click **Save**.

# Video Outputs

The frame has a number of output HD-BNCs that can have any video source in the switcher, including Media-Store channels, aux bus, and clean feed assigned to them.

## UHDTV1 Outputs

With the exception of the MultiViewer outputs, all video outputs are a single 12Gb/s UHD-2SI signal. An FSFC can be assigned to the output to convert it to a single link HD signal. Quad-Link output is not supported.

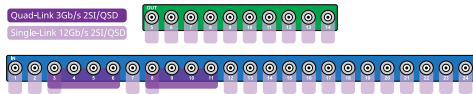

Figure 9: UHD Input/Output

## Video Output Setup

You can assign a video source or bus to an output BNC. Some outputs can only be used for certain features

Out BNC	Vid Proc MultiViewer	I/O MultiViewer	Down Converters
1	no	yes	no
2	no	yes	no
3	yes	no	no
4	yes	no	no
5-14	no	no	yes

### To Set up a Video Output

Assign video sources or buses to the output HD-BNCs on the back of the switcher. Some outputs are fixed to a specific video signal.

1. Click **Navigation Menu > Configuration > Outputs.**



**Note:** The number of outputs that can be configured depends on the video mode the switcher is operating in and the number of ABMs connected to the switcher.

**Tip:** Refer to [Output FSFC](#) on page 118 for information on conversion, and [To Configure Audio Outputs](#) on page 57 for information on embedding audio into video outputs.

2. Click on the **Source** button for the output BNC that you want to assign a source to.



3. Click the video source that you want to assign to the output.
  - **Physical** — the physical inputs to the switcher on the input BNCs.
  - **Internal** — the internally generated sources of the switcher (ME, MiniME™, chroma key outputs, etc.).
    - **BK** — black
    - **BG** — matte generator
    - **MX** — Media-Store video channel X
    - **MXA** — Media-Store alpha channel X
    - **MEXMW** — Media-Store video channel used for MediaWipe effects on ME X (if installed)
    - **MEXMA** — Media-Store alpha channel used for MediaWipe effects on ME X (if installed)
    - **MinMEX** — main program output of MiniME™ X
    - **MMX PV** — main preview output of MiniME™ X
    - **MMXCmb** — combined alpha of MiniME™ X
    - **PGM** — main program output of the switcher
    - **PRV** — main preview output of the switcher
    - **CLN** — clean feed for main program of switcher
    - **MEX** — main program output of ME X (if installed)
    - **MEX PV** — main preview output of ME X (if installed)
    - **MEX CL** — clean feed output of ME X (if installed)
    - **CKX** — chroma key X video
    - **CKXA** — chroma key X alpha
  - **Aux Follows** — the aux buses.
  - **ME Follows** — the background, preset, and key buses of each ME.
    - **MEXBg** — source on background of ME X (if installed)
    - **MEXPst** — source on preset output of ME X (if installed)

- **MEXKYV** — key Y video of ME X (if installed)
- **MEXKYA** — key Y alpha of ME X (if installed)
- **MiniME Follows** — the background, preset, and key buses of each MiniME™.
  - **MMXBg** — source on background of MiniME™ X
  - **MMXPst** — source on preset output of MiniME™ X
  - **MMXKYV** — key Y video of MiniME™ X
  - **MMXKYA** — key Y alpha of MiniME™ X
- **Canvas Follows** — the background, preset, and key buses of each Canvas.
  - **CanXBg** — source on background of Canvas X
  - **CanXPst** — source on preset output of Canvas X
  - **CanXKYV** — key Y video of Canvas X
  - **CanXKYA** — key Y alpha of Canvas X

**Note:** The MiniME™ preset only shows the source that is selected on the preset bus for the MiniME™. This does not include keys or any video manipulation that is done if the MiniME™ is used as part of a Canvas.

4. In the **Text** column, enter a new name for each output you want to identify differently. The name is used to identify the output on the panel mnemonics as well as on menus.

## Output Rotation

Rotate a video output in 90° increments.

The output rotation allows you to rotate the video on outputs 12-14 in 90° increments clockwise. The video can then be zoomed and shifted in the X and Y axis.

**Tip:** The rotated output can be assigned to a box on the I/O MultiViewer.

### Keep the following in mind:

Keep the following in mind when working with output rotation:

- There are no dedicated custom control events in the editor for Output rotation. You must start recording a CC and make the rotation changes.

- You can apply color correction, dynamic range, and color gamut adjustment to the rotated video.
- Output rotation is only available in outputs 12-14.
- Output rotation is only available in HD ROT 4 Key or HD ROT 6 Key switcher modes.

### To Rotate a Video Output

The video outputs can be rotated, zoomed, and shifted in the X/Y axis.

**Note:** Only outputs 12-14 can be rotated.

1. Click **Navigation Menu > Configuration > Outputs**.

**Note:** Rotation is only available in the HD ROT 4 Key and HD ROT 6 Key switcher modes.



2. Click the **Rotation** button for the output you want to rotate.



3. Adjust the rotation of the video output.
  - **Off** — the output rotation is no applied to the output.
  - **0°** — the video output is not rotated.
  - **90°** — the video output is rotated 90° clockwise.
  - **180°** — the video output is rotated 180° clockwise.
  - **270°** — the video output is rotated 270° clockwise.

**Tip:** You can use the 0° rotation in a memory or custom control if you need to rotate the output and then rotate it back without turning the rotation feature on and off.

4. Adjust the zoom and position of the video output.

- **Zoom** — increase the size of the video. Some zoom is always applied to the video to ensure it fills the output screen.
- **X-Position** — move the video left or right. The x-axis always remains in the same direction as the video is rotated.
- **Y-Position** — move the video up or down. The x-axis always remains in the same direction as the video is rotated.

**Note:** If no zoom is applied to the video you will not be able to adjust the X or Y-Position. You cannot move the video off of the visible screen area.

## Ancillary Data

Ancillary data is information such as closed captioning or embedded audio that is included in the non-active video portions of the video signal. These portions include the Horizontal Ancillary Data Space (HANC) and Vertical Ancillary Data Space (VANC).

The switcher can be configured to strip or pass this data from the video output.

**Note:** Frame Converters and Synchronizers strip embedded audio data from the video signal.

The following restrictions apply to ancillary data being included in the output:

- All ME program buses pass ancillary data.
- MultiViewer outputs do not include any ancillary data.
- MiniME™ and Canvas outputs do not include any ancillary data unless an ME with ancillary data is re-entered onto the background bus.
- ME Preview does not include ancillary data unless the background is not selected as part of the next transition.
- A MiniME™ or Canvas can include ancillary data if an ME is re-entered onto the background.
- Any format conversion on the input video signal.
- Setting ancillary data to be stripped.

### To Strip or Pass Ancillary Data

Strip or pass ancillary data on video outputs. Video manipulation such as FSFC conversion automatically strips ancillary data from the video signal.

1. Click **Navigation Menu > Configuration > System > Global**.



2. Click an **Ancillary Mode** button to select whether ancillary data is stripped or passed.
  - **Strip** — ancillary data is stripped
  - **Pass** — ancillary data is passed unmodified

## FlexiClean Clean Feed

FlexiClean clean feed provides a second program output per ME that is derived from a different point in the video layering than the standard program output. The clean feed can be set to come before any key in the video layering for an ME. This allows you to remove particular keys without affecting the primary program output.

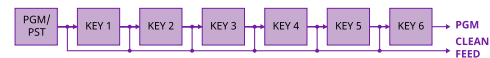

### Keep the following in mind:

Keep the following in mind when working with clean feeds:

- Recalling a memory register using MemoryAI may cause the clean feed output to look different than expected. MemoryAI allows key elements to be recalled to other keys than originally resulting in different key layering.

### To Set Up Clean Feed

Clean Feed can be taken before any or all of the keyers on an ME. This allows you to have a secondary output of an ME without any branding for re-broadcast or archival.

1. Click **Navigation Menu > Configuration > System > ME**.

**Note:** The number of keyers depends on whether the switcher is operating in a 4-Key or 6-Key mode.



2. Click an **ME X Clean Feed** button to select which key the clean feed for that ME is taken before.

The selected key, and all keys after it, are not included in the clean feed output.

## External Layer Mode

The clean feed for an ME is used to create a composite alpha from the keyers on that ME that is then available as a single alpha source. This allows you to output both the video and alpha from an ME to an external switcher. The key video comes from the output of the ME and the key alpha comes from the clean feed of the ME.

The alphas that are included in the layer mode output are set with the keyer buttons in the next transition area. Toggle a keyer button on to include the alpha from that keyer in the layer mode output.

When layer mode is turned on for an ME, you are restricted to cut, dissolve, and wipe transitions. MediaWipe and DVE transitions are not available.

**Tip:** To use layer mode internally, select the clean feed for the ME that is set to layer mode as the alpha for an auto key on another ME or a MiniME™.

### To Set Up Layer Mode

Use the clean feed to output a composite alpha of the keys on that bus.

1. Click **Navigation Menu > Configuration > System > ME**.

**Note:** The number of MEs depends on the licences installed and whether the switcher is operating in a 4-Key, 6-Key, or UHD mode.



2. Click an **ME X Layer Mode** button to turn layer mode on (**On**), or (**Off**) for that ME.

## ME Follows

An ME or MiniME™ can be linked to another ME or MiniME™ so that actions performed on the first are duplicated on the following. Linking can only be set between areas of the same type. You cannot have a MiniME™ follow an ME.

**Tip:** The ME follows can also be used with the substitution table feature to create multilingual production feeds. For example, you can have ME 2 follow ME 1 to simultaneously produce multiple feeds. When a source is selected on ME 1, the same source is selected on ME 2. With the substitution table you can have it that when camera 1 is selected on ME 1 the follow will select camera 1 on ME 2 but the substitution table substitutes camera 4 for camera 1 on ME 2.

### Keep the following in mind:

Keep the following in mind when working with ME Follows:

- You cannot have a MiniME™ follow an ME.
- There must be available resources for the following ME or MiniME™.
- Memories and resets are also performed on the following ME or MiniME™.
- Chroma Key initialization is only performed on the leading ME or MiniME™. The following ME or MiniME™ get the same chroma key parameters as the leading ME or MiniME™. If you are substituting the source on the following ME or MiniME™ the chroma key will not be initialized properly for that source.
- You must turn the MultiScreen off to be able to set the follows for the MiniME™.
- You cannot cascade/re-enter follows. For example, if MiniME™ 1 is following MiniME™ 2, MiniME™ 2 cannot be set to following anything and no other MiniME™ can follow MiniME™ 1.

### To Set Up an ME Follow

Set an ME or MiniME™ to follow another ME or MiniME™. Actions on the first ME or MiniME™ are duplicated on the following ME or MiniME™.

1. Click **Navigation Menu > Configuration > System > ME**.



2. Click the **ME X Follow** or **MiniME X Follow** button for the ME that you want ME or MiniME™ X to follow.

For example, click **ME 2** in the **ME 1 Follow** row to have actions performed on ME 2 duplicated on ME 1.

---

**Note:** The MiniME™ follows are only available if the MiniME™ is not being used for a MultiScreen. You must turn the MultiScreen off to be able to set the follows for the MiniME™.

**Tip:** Select **Off** to have the ME or MiniME™ not follow anything.

## On-Air Setting

Some switcher outputs can be set to be considered on-air or not. This allows you to set which outputs are tallied, how resource allocation is divided, and how the Roll Clip feature works.

### To Set the On-Air Status for an Output

Set an output to be on-air to tally sources that are selected on that bus.

1. Click **Navigation Menu > Configuration > On Air**.

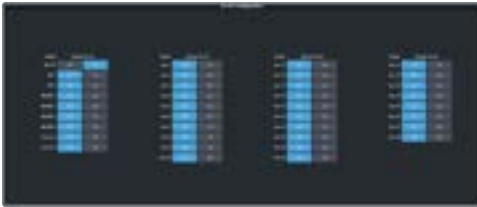

2. Click an **Always OnAir** button for an output to select whether the output is considered on-air (**On**) or not (**Off**).

**Tip:** Setting an output to be always on-air tallies sources that are selected on that bus, or are going to be taken on-air with the next transition.



# MultiViewer

The MultiViewer allows you to view multiple video sources from a single output BNC. Video inputs or outputs on the switcher, including Program, Preview, and Media-Store channels, can be assigned to any box on the MultiViewer. Both I/O MultiViewer and Video Processor MultiViewer are supported by the switcher. These MultiViewers differ in the video sources they have access to.

- **I/O MultiViewer** — all input BNCs and output BNCs 5-12 (5-14 in a Rotation (ROT) switcher mode).
- **Video Processor MultiViewer** — all input BNCs and all video bus outputs, source overlay, and used for ViewControl

*Tip: The I/O MultiViewer can show you what is assigned to a specific output BNCs where the Video Processor MultiViewer can show you what is selected on a specific bus. For example, the Video Processor MultiViewer can show you what is selected on ME 1 key 2, where the I/O MultiViewer can show you the video that is being fed out of BNC 6.*

A time-clock can be added as an overlay to the MultiViewer showing either system time or time code.

## Keep the following in mind:

Keep the following in mind when working with a MultiViewer:

- I/O MultiViewer outputs are assigned to output BNCs 1-2.
- Video Processor MultiViewer outputs are assigned to output BNCs 3-4.
- Only the Video Processor MultiViewer can be used for ViewControl.
- You cannot view output BNCs 13-14 on the I/O MultiViewer in SD or HD mode, unless you are in a Rotation (ROT) switcher mode.
- Only the Video Processor MultiViewers (BNCs 3-4) can have audio from the mixer assigned to them.
- The layout is configured independently for each MultiViewer.
- Inputs are displayed with a red tally box when they are on-air. A green tally box is displayed when the input is selected on the Preset bus.
- When the switcher is operating in a standard-definition video format, the MultiViewer is shown in high-definition.

- All ancillary data is stripped from the MultiViewer outputs.

## MultiViewer Output Formats

Depending on the format the switcher is operating in, the MultiViewer may output a different video format than the switcher is operating in.

Switcher Video Format	MultiViewer Format
480i	1080i 59.94Hz
576i	1080i 50Hz
720p 50Hz	720p 50Hz
720p 59.94Hz	720p 59.94Hz
1080i 50Hz	1080i 50Hz
1080i 59.94Hz	1080i 59.94Hz
1080pSF 23.98Hz	1080pSF 23.98Hz
1080pSF 24Hz	1080pSF 24Hz
1080pSF 25Hz	Video Processor MultiViewer — 1080i 50Hz
	I/O MultiViewer — 1080pSF 25Hz
1080pSF 29.97Hz	Video Processor MultiViewer — 1080i 59.94Hz
	I/O MultiViewer — 1080pSF 29.97Hz
1080pSF 30Hz	1080pSF 30Hz
1080p 23.98Hz	1080p 23.98Hz
1080p 24Hz	1080p 24Hz
1080p 25Hz	1080p 25Hz
1080p 29.97Hz	1080p 29.97Hz
1080p 30Hz	1080p 30Hz
1080p 50Hz	1080p 50Hz
1080p 59.94Hz	1080p 59.94Hz
1080p 60Hz	1080p 60Hz
UHDTV1 23.98Hz	1080p 23.98Hz
UHDTV1 24Hz	1080p 24Hz
UHDTV1 25Hz	1080p 25Hz
UHDTV1 29.97Hz	1080p 29.97Hz
UHDTV1 30Hz	1080p 30Hz
UHDTV1 50Hz	1080p 50Hz
UHDTV1 59.94Hz	1080p 59.94Hz
UHDTV1 60Hz	1080p 60Hz

## To Set Up an I/O MultiViewer

Select a layout for the MultiViewer, assign sources to the boxes, and configure mnemonic names and tallies.

1. Click **Navigation Menu > Configuration > MultiViewers** and click the **MV IO** button for the I/O MultiViewer you want to set up.



2. Click the **Layout** button and select the arrangement of the boxes that you want to use for the selected I/O MultiViewer.



3. Use the **Transparency** slider to adjust the transparency of the background behind the source label for the selected I/O MultiViewer.
4. Click a **Tally** button to select how boxes on the Video Processor MultiViewer are tallied.
  - **Box** — red or green border is shown around the outside of the Video Processor MultiViewer box
  - **Label** — red or green boxes are shown inside the label area of the Video Processor MultiViewer box
  - **Label Reverse** — the same as Label, but the placement of the tally boxes is swapped
5. Click an **FS Label** button to select whether FSFC is shown on the source labels (**On**) or not (**Off**) when a FSFC is applied to the source.
6. Click **Shift Panel** and select the panel that you want the MultiViewer shift to be active on. When the **Shift** button is pressed on the assigned control panel the MultiViewer shows the shifted sources.

**Note:** The shift function can only be assigned to a single panel at a time.



**Tip:** When the MultiViewer Shift is active, the box buttons on the layout show the shifted source in brackets.

7. Click on one of the **Boxes** buttons and set up how that box appears on the I/O MultiViewer in the standard and shifted configuration.



- **Physical** — the physical inputs to the switcher on the input BNCs.
- **Outputs** — the physical outputs from the switcher on the output BNCs.

8. Select how you want that box to appear on the I/O MultiViewer.

**Tip:** Click **Apply to All** to have the settings for the current box applied to all boxes in MultiViewer. This does not include what video source is assigned to the box.

Option	Description
<b>Green Tally</b>	Turn the preview (green) tally for the I/O MultiViewer box on or off.
<b>Red Tally</b>	Turn the program (red) tally for the I/O MultiViewer box on or off.
<b>Border</b>	Turn the border around the I/O MultiViewer box off ( <b>Off</b> ), white ( <b>White</b> ), or black ( <b>Black</b> ). When the border is turned off, some distortion may be visible around the edges of the box.
<b>Label</b>	Turn source labels for the I/O MultiViewer box off, or on in a selected position.
<b>Label Pos</b>	Select a position for the source label for the I/O MultiViewer box ( <b>Bottom</b> or <b>Top</b> ).

Option	Description
<b>Display</b>	<p>Select what name is shown on the label.</p> <ul style="list-style-type: none"> <li>• <b>Fixed</b> — show only the text entered in the <b>Fixed Label</b> field as the name.</li> <li>• <b>Switcher</b> — show only the internal mnemonic name.</li> <li>• <b>Router</b> — show only the TSL UMD name.</li> <li>• <b>Switcher and Router</b> — show both the internal and TSL UMD name</li> </ul> <p><i>Tip: If you select a source on an aux bus that does not have a TSL UMD name, the mnemonic name is used instead on the MultiViewer.</i></p>
<b>Aspect</b>	Turn aspect ratio markers for the I/O MultiViewer box on ( <b>Aspect</b> ) or off ( <b>Off</b> ).
<b>Shift Source</b>	Turn the shifted source on ( <b>On</b> ) or off ( <b>Off</b> ) for the selected box. When the MultiViewer is shifted, the source in this box will not change.

## To Set Up a Video Processor MultiViewer

Select a layout for the Video Processor MultiViewer, assign sources to the boxes, and configure mnemonic names and tallies.

1. Click **Navigation Menu > Configuration > MultiViewers** and click the **MV VP** button for the Video Processor MultiViewer you want to set up.



2. Click the **Layout** button and select the arrangement of the boxes that you want to use for the selected Video Processor MultiViewer.



3. Use the **Transparency** slider to adjust the transparency of the background behind the

source label for the selected Video Processor MultiViewer.

4. Apply an overlay to the Video Processor MultiViewer as follows:
  - a) Click the **Overlay** button and click **On** to turn the overlay on, or **Off** to turn it off.



*Note: The overlay feature is only available when a layout of less than 16 boxes is used.*

*Tip: The overlay is primarily used for Video Processor MultiViewer, but can also be used to overlay a camera shot of a shot-clock over the MultiViewer output.*

- b) Click the **Source** button for the video source that you want to overlay over the Video Processor MultiViewer output.
- c) Use the **Clip** slider to adjust the clipping of the overlay source.

At **0%** the overlay source is completely opaque, and at **100%** it is completely transparent.

5. Click a **Tally** button to select how boxes on the Video Processor MultiViewer are tallied.
  - **Box** — red or green border is shown around the outside of the Video Processor MultiViewer box
  - **Label** — red or green boxes are shown inside the label area of the Video Processor MultiViewer box
  - **Label Reverse** — the same as Label, but the placement of the tally boxes is swapped
6. Click an **FS Label** button to select whether FSFC is shown on the source labels (**On**) or not (**Off**) when a FSFC is applied to the source.
7. Click **Shift Panel** and select the panel that you want the MultiViewer shift to be active on. When the **Shift** button is pressed on the assigned control panel the MultiViewer shows the shifted sources.

**Note:** The shift function can only be assigned to a single panel at a time.

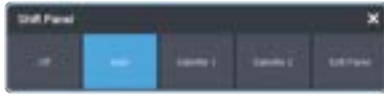

**Tip:** When the MultiViewer Shift is active, the box buttons on the layout show the shifted source in brackets.

- Click on one of the **Boxes** buttons and set up how that box appears on the Video Processor MultiViewer in the standard and shifted configuration.



- **Physical** — the physical inputs to the switcher on the input BNCs.
- **Internal** — the internally generated sources of the switcher (ME, MiniME™, chroma key outputs, etc.).
- **Aux Follows** — the aux buses.
- **ME Follows** — the background, preset, and key buses of each ME.
- **MiniME Follows** — the background, preset, and key buses of each MiniME™.
- **Canvas Follows** — the background, preset, and key buses of each Canvas.

- Select how you want that box to appear on the I/O MultiViewer.

**Tip:** Click **Apply to All** to have the settings for the current box applied to all boxes in MultiViewer. This does not include what video source is assigned to the box.

Option	Description
<b>Green Tally</b>	Turn the preview (green) tally for the I/O MultiViewer box on or off.
<b>Red Tally</b>	Turn the program (red) tally for the I/O MultiViewer box on or off.
<b>Border</b>	Turn the border around the I/O MultiViewer box off ( <b>Off</b> ), white ( <b>White</b> ), or black ( <b>Black</b> ). When the border is turned off, some distortion may be visible around the edges of the box.
<b>Label</b>	Turn source labels for the I/O MultiViewer box off, or on in a selected position.

Option	Description
<b>Label Pos</b>	Select a position for the source label for the I/O MultiViewer box ( <b>Bottom</b> or <b>Top</b> ).
<b>Display</b>	Select what name is shown on the label. <ul style="list-style-type: none"> <li>• <b>Fixed</b> — show only the text entered in the <b>Fixed Label</b> field as the name.</li> <li>• <b>Switcher</b> — show only the internal mnemonic name.</li> <li>• <b>Router</b> — show only the TSL UMD name.</li> <li>• <b>Switcher and Router</b> — show both the internal and TSL UMD name</li> </ul> <p><b>Tip:</b> If you select a source on an aux bus that does not have a TSL UMD name, the mnemonic name is used instead on the MultiViewer.</p>
<b>Aspect</b>	Turn aspect ratio markers for the I/O MultiViewer box on ( <b>Aspect</b> ) or off ( <b>Off</b> ).
<b>Shift Source</b>	Turn the shifted source on ( <b>On</b> ) or off ( <b>Off</b> ) for the selected box. When the MultiViewer is shifted, the source in this box will not change.

## MultiViewer Clock

The clock can show the current system time, LTC data being sent to the switcher, or a countdown timer. The clock can only operate in a single mode at one time.

### To Set Up a MultiViewer Timecode Clock

The timecode clock uses LTC data being sent to the switcher and displays it as (hh:mm:ss:ff).

- Click **Navigation Menu > Configuration > MultiViewers** and select the MultiViewer that you want to apply the clock overlay to.
- Click **Clock > Timecode**.



- Click a **Frame Count** button to select whether the number of frames for a timecode is displayed (**On**) or not (**Off**).
- Click the **Position** tab.

5. Use the **X Position**, **Y Position**, and **Size** sliders to position the clock and change the size.
6. Click the **Foreground Color** tab and select the color and transparency you want to use for the text of the clock.



7. Click the **Background Color** tab and select the color and transparency you want to use for the background of the clock.

### To Set Up a MultiViewer System Clock

The clock can show the current system time in 12-hour or 24-hour format (hh:mm:ss).

1. Click **Navigation Menu > Configuration > MultiViewers** and select the MultiViewer that you want to apply the clock overlay to.
2. Click **Clock > System**.



3. Click a **Time Display** button to set how the time is displayed.
  - **24 hr** — time is displayed in 24-hour format.
  - **12 hr** — time is displayed in 12-hour format without am/pm.
  - **12 hr AM/PM** — time is displayed in 12-hour format with am/pm.
4. Click the **Position** tab.
5. Use the **X Position**, **Y Position**, and **Size** sliders to position the clock and change the size.
6. Click the **Foreground Color** tab and select the color and transparency you want to use for the text of the clock.



7. Click the **Background Color** tab and select the color and transparency you want to use for the background of the clock.

### To Set Up a MultiViewer Countdown Timer

The clock can show a countdown timer that will count down from a set time to 0, up from 0, or down from a set time to 0 and then up.

1. Click **Navigation Menu > Configuration > MultiViewers** and select the MultiViewer that you want to apply the clock overlay to.
2. Click **Clock > Countdown Timer**.



3. Click a **Timer** button to select which countdown timer you want to use. Each timer can be set up differently.

**Note:** *Timer are shared across all MultiViewers.*

4. Click a **Direction** button to select the direction that the times counts in.
  - **Down** — enter a time in the **Minutes** and **Seconds** field that the timer will start counting down from. The timer stops when it reaches 0.
  - **Up** — the timer counts up from 0 until stopped.
  - **Down/Up** — enter a time in the **Minutes** and **Seconds** field that the timer will start counting down from. The timer counts down to 0 and then starts counting up until stopped.

**Tip:** *You can manually control the countdown timer using the **Start** and **Reset** buttons, or assign these commands to custom controls.*

5. Click the **Position** tab.
6. Use the **X Position**, **Y Position**, and **Size** sliders to position the clock and change the size.
7. Click the **Foreground Color** tab and select the color and transparency you want to use for the text of the clock.



8. Click the **Background Color** tab and select the color and transparency you want to use for the background of the clock.

# MultiScreen

MultiScreen works by breaking your display into individual panels. Each panel is represented by a tile in MultiScreen and the entire display is represented by the canvas.

To properly set up MultiScreen you must calculate the total number of pixels on your display (width and height). In the example shown below we are using a display that is 3840 pixels wide and 2160 pixels high. This information is entered as the canvas size.

**Tip:** MultiScreen uses a MiniME™ to create a tile. The two terms are used interchangeably in the menus.



Venue Display = Canvas Size  
(3840x2160 pixels)

Once the canvas has been set, you need to calculate how many tiles it will take to cover the canvas. The size of the tiles is determined by the video format the switcher is operating in. For example, if you are a 1080 format, each tile will be 1920 pixels wide by 1080 pixels high. MultiScreen can automatically position the tiles in an X by Y grid over the canvas.

**Tip:** If your canvas is larger or smaller than the grid of tiles, make sure to use enough tiles to cover the entire canvas.



(Tile = 1920x1080 pixels)

Putting video onto the tiles can be done in a number of ways, depending on how the background graphic you want to use was created. In the case of a pre-tiled source, the background image has already been divided up into individual segments. A separate video source is fed into the switcher for each tile. In the example below, tile 1 is fed the video source

on BNC 1 (Source 1), tile 2 is fed from BNC 2, and so on.

**Tip:** When dealing with pre-tiled sources, it is recommended that you set up a substitution table for all the sources you will use. This allows you to select a source on one MiniME™ and have the switcher automatically select the corresponding sources on the other MiniME™ buses.



Pre-Tiled Source  
(Sources = 4)

Alternatively to the pre-tiles sources, MultiScreen can use DVE resources to stretch a single image over the entire background.



Background DVE  
(Sources = 1 stretched)

## MultiScreen Video Processor Setup

The MultiScreen compositing engine allows you to map switcher outputs (Tile/MiniME™) to regions on your LED display (Canvas). With the tiles laid out on the canvas, background images can be stretched (Background DVE) or tiled (Pre-Tiled Source) across the entire canvas.

**Tip:** The size and number of the canvases depends on the number of tiles you have available.



Keys are automatically interpolated between tiles across the entire canvas. As the key moves from one tile to another, the keyer for that

MiniME™ takes over. You must keep in mind how many keyers you are using on each tile as you move keys around the canvas.



### MultiScreen Terms

The following terms are used when discussing MultiScreen:

- **Canvas** — The pixel-based surface area of your LED display. For irregular shaped display assemblies, your canvas should be the maximum height and width of you display.
- **Tile** — The individual MiniME™ video outputs of the switcher that go to each panel of the display. How the tiles are arranged on the canvas must match how the panels are arranged on the display.
- **Bezel** — The pixel compensation for any bezel on the edges of the individual panels that make up the display. Bezel compensation in the absolute distance between the active pixels on the panels, and not the size of the bezel on each panel. Adjust bezel values based on visual inspection of active video on the display.
- **Background DVE** — DVE resources are used to stretch the background image to cover the entire canvas. DVE resources may not be needed if pre-tiled sources are used with the substitution table.
- **Pre-Tiled Sources** — The background image has already been separated for each tile of the canvas. Each part is fed into the switcher as a separate video source and a substitution table is used to tell the switch which source to put on each tile/MiniME™.

### Keep the following in mind:

Keep the following in mind when setting up MultiScreen:

- The Canvas uses MiniME™/Tile resources to provide the keys and outputs. As a key crosses from one tile to the next, a key from

either of the MiniME™/Tile outputs is being used to provide the two halves of the key.

- The Canvas can either take separate parts of a pre-tiled source, or scale a single source to the size of the Canvas output. When you use a pre-tiled source, you must assign sources to each MiniME™/Tile that is used in the Canvas. This substitution table allows you to select a single source on the Canvas program bus and the switcher automatically assigns the required source to each MiniME™/Tile.
- The Canvas does not support edge blending.
- In UHDTV1 there are only 2 MiniME™/Tile outputs.
- If you are using a Background DVE for your Canvas, you must use the **Canvas X** controls in Live Assist to stretch or position the DVE key.

## To Set Up MultiScreen

Create your canvas and then overlay tiles to cover the canvas area with video.

1. Click **Navigation Menu > Configuration > Canvases**.



2. Click **Canvas X** to select the Canvas you want to set up.

On the right of the screen is a canvas workspace with a visual representation of the canvas in red. Tiles appear as numbered gray boxes in the workspace. The MiniME™/tiles are the only outputs of the system. The canvas is shown to help visualize the placement of the tiles and should be the same pixel size as your target display.

3. Click a **CanX** button for each **Tile/MiniME** to assign that tile to the selected canvas. A tile can only be applied to one canvas at a time.

**Tip:** Click **Off** to have the tile not applied to any of the canvases. This does not turn off the output of the MiniME™.

The tiles appears as a grey boxes on the canvas workspace you apply them to.



- In the **Canvas Size** area, enter the **Width** and **Height** of your display in pixels.  
A red box representing the canvas is shown in the workspace.

- Click **Layout Presets** and select how you want the tiles arranged on the canvas.

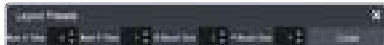

- **Num X Tiles** — enter the number of columns of tiles you want.
- **Num Y Tiles** — enter the number of rows of tiles you want.
- **X Bezel Size** — enter the size of the gap you want between columns of tiles to compensate for display bezels or projector edges. This is the total gap and not the size of an individual bezel.
- **Y Bezel Size** — enter the size of the gap you want between rows of tiles to compensate for display bezels or projector edges. This is the total gap and not the size of an individual bezel.

**Note:** The canvas size does not automatically compensate for bezel offsets.

- Click **Create**.  
The tiles are laid out on the canvas from the top/left corner to the bottom/right corner.
- Click a **Background DVEs** button to select how DVE resources are used to scale sources for the Canvas screen.
  - **Off** — DVE resources are not allocated to the Canvas for scaling of background sources.
  - **On** — DVE resources are always allocated to the Canvas for scaling of background sources. This reduces the number of available DVE resources to the switcher when a Canvas is turned on.
  - **Dynamic** — DVE resources are dynamically allocated to the Canvas for scaling of background sources if there is no substitution table.

**Note:** If there are no DVE resources to scale the background source across the entire Canvas, the switcher needs a substitution table to map separate inputs to the Canvas screens or the selected source is repeated in each screen of the Canvas.

**Tip:** Click **Navigation Menu > Live Assist > MEs > Canvas X > BkgDVE** to control the size and position of the background DVE used by the selected Canvas.

- Click **OK**.
- Click a **MV 1 Follow** button to have MultiViewer 1 mimic the current tile layout.

**Note:** The MultiViewer layout only follows the last layout that you generated (**Layout Preset**). Manually moving tiles around is not followed in the MultiViewer. The MultiViewer can only mimic layouts that currently exist as MultiViewer layouts.

## To Set Up a Pre-Tiled Source

The substitution table is a single table that allows you to specify a different source that should be taken when a specific source is selected on a bus. The substitution table requires either a Canvas or ME follow to be set up between the buses to trigger the substitution.

**Tip:** When you select the Source on the ME/Bus, the Substitution source is taken instead.

- Click **Navigation Menu > Configuration > Inputs > Substitutional**.



- Click **New ME Sub** or **New Bus Sub** to select the type of substitution table you want to set up.
  - **New ME Sub** — create a substitution on an ME or MiniME™.
  - **New Bus Sub** — create a substitution on a key bus of an ME or MiniME™, or an aux bus.
- Click the **Source** button and select the source that you want to substitute with another source.
- Click the **ME** or **Bus** button and select the area that you want the substitution to occur on.
- Click the **Substitution** button and select source you want to substitute for the selected one. Repeat for any addition substitutions you want to create.
- Click **Save**.

## I/O Processors

The Input/Output Video Processors are independent video processing engines that allow you to perform FSFC and color correction functions on specific inputs or outputs. Once an I/O Processor has been assigned to an input or output, it can be used to frame sync, format convert, and color correct.

The number of I/O Processors you have depends on the options installed. The switcher comes standard with 8 (2 in UHDTV1) I/O Processors and is upgradable to 34 (8 in UHDTV1).

How I/O Processor are assigned depends on whether the switcher is operating in SD, HD, or UHDTV1.

### To Assign an I/O Processor to an Input or Output (SD or HD Only)

When you don't have the CUF-ADD-I/OPLUS software option activated, you must assign an I/O Processor to the input or output you want to convert. Once assigned you can turn on the FSFC and color correction for that video. The CUF-ADD-I/OPLUS option provides resources for every input and output.

**Note:** This menu is not available when the Extra SD or HD I/O Processor option is activated.

**Note:** In UHDTV1 you must assign individual FSFCs and color correctors to inputs and outputs.

1. Click **Navigation Menu > Configuration > Reference**.



2. In the **IO Processor Assignment** area, click the **IO Processor X** button for the I/O Processor you want to use.



3. Click a **Input/Output** button to select the video input or output that you want to assign the I/O Processor to.

**Tip:** Click **Off** to take the I/O Processor out of the video path for the selected input or output.

## Frame Sync and Format Conversion

The frame synchronizer / format converter (FSFC) and input i-to-p converters that can be used to convert video signals as well as correct mistimed, or drifting, video input signal. The frame synchronizers cannot completely correct badly formatted video, mistimed switches, signal drops, or similar issues. Output format converters are only available on outputs 5-14.

The CUF-ADD-I/OPLUS option provides 24 FSFC in HD (7 in UHDTV1).

Each FSFC channel maintains a separate setting for different video formats. This lets you change between video formats without losing FSFC channel configurations.

### Keep the following in mind:

Keep the following in mind when working with Frame Synchronizers and Format Converters:

- If a video format not compatible with the currently defined conversion is used, the video image is frozen with the last successfully processed image frame.
- FSFCs create a one-frame delay in the video output of the switcher for the video signal being converted.
- FSFCs strip embedded audio data from the video signal. Ensure that no FSFC channels are assigned to any input or bus you are using with external audio mode.
- The SD or HD output format converters are only available on output BNCs 5 to 14.
- The FSFCs used in the switcher conform to the SMPTE ST 125:2013 standard. Some older equipment may not fully conform to the current standards and can send out-of-spec video to the switcher which can have unexpected results. Ensure that video coming into the switcher conforms to current standards, especially with regard to 480i video signals with variable blanking sizes.
- An FSFC is required for Quad-Link 3Gb/s UHD-2SI inputs. You must assign an FSFC to the first input of the quad-link 3Gb/s UHD-2SI or UHD-QSD inputs.

## Supported FSFC Video Formats

FSFCs can only convert between specific video formats at a given frequency. The available conversions also depends on the switcher mode you are in. References to 1080p 59.94Hz (A) and 1080p 50Hz (A) refer to 1080p Level A only.

**Table 3: Supported FSFC Input and Output Formats**

Input	Switcher	Output
UHDTV1 60Hz (Single 12Gb/s UHD-2SI)	UHDTV1 60Hz	UHDTV1 60Hz (Single 12Gb/s UHD-2SI)
UHDTV1 60Hz (Quad 3Gb/s UHD-2SI) <sup>3</sup>		
UHDTV1 60Hz (Quad 3Gb/s UHD-QSD) <sup>3</sup>		
720p 60Hz		720p 60Hz
1080i 60Hz		1080i 60Hz
1080p 60Hz (A)		1080p 60Hz (A)
UHDTV1 59.94Hz (Single 12Gb/s UHD-2SI)	UHDTV1 59.94Hz	UHDTV1 59.94Hz (Single 12Gb/s UHD-2SI)
UHDTV1 59.94Hz (Quad 3Gb/s UHD-2SI) <sup>3</sup>		
UHDTV1 59.94Hz (Quad 3Gb/s UHD-QSD) <sup>3</sup>		
720p 59.94Hz		720p 59.94Hz
1080i 59.94Hz		1080i 59.94Hz
1080p 59.94Hz (A)		1080p 59.94Hz (A)
UHDTV1 50Hz (Single 12Gb/s UHD-2SI)	UHDTV1 50Hz	UHDTV1 50Hz (Single 12Gb/s UHD-2SI)
UHDTV1 50Hz (Quad 3Gb/s UHD-2SI) <sup>3</sup>		
UHDTV1 50Hz (Quad 3Gb/s UHD-QSD) <sup>3</sup>		
720p 50Hz		720p 50Hz
1080i 50Hz		1080i 50Hz
1080p 50Hz (A)		1080p 50Hz (A)

Input	Switcher	Output
UHDTV1 30Hz (Single 6Gb/s UHD-2SI)	UHDTV1 30Hz	UHDTV1 30Hz (Single 6Gb/s UHD-2SI)
UHDTV1 30Hz (Single 1.5Gb/s UHD-QSD) <sup>3</sup>		
1080p 30Hz		
1080pSF 30Hz		
720p 30Hz		
UHDTV1 29.97Hz (Single 6Gb/s UHD-2SI)	UHDTV1 29.97Hz	UHDTV1 29.97Hz (Single 6Gb/s UHD-2SI)
UHDTV1 29.97Hz (Single 1.5Gb/s UHD-QSD) <sup>3</sup>		
1080p 29.97Hz		
1080pSF 29.97Hz		
720p 29.97Hz		
UHDTV1 25Hz (Single 6Gb/s UHD-2SI)	UHDTV1 25Hz	UHDTV1 25Hz (Single 6Gb/s UHD-2SI)
UHDTV1 25Hz (Single 1.5Gb/s UHD-QSD) <sup>3</sup>		
1080p 25Hz		
1080pSF 25Hz		
720p 25Hz		
UHDTV1 24Hz (Single 6Gb/s UHD-2SI)	UHDTV1 24Hz	UHDTV1 24Hz (Single 6Gb/s UHD-2SI)
UHDTV124Hz (Single 1.5Gb/s UHD-QSD) <sup>3</sup>		
1080p 24Hz		
1080pSF 24Hz		
720p 24Hz		
UHDTV1 23.98Hz (Single 6Gb/s UHD-2SI)	UHDTV1 23.98Hz	UHDTV1 23.98Hz (Single 6Gb/s UHD-2SI)
UHDTV1 23.98Hz (Single 1.5Gb/s UHD-QSD) <sup>3</sup>		
1080p 23.98Hz		
1080pSF 23.98Hz		
720p 23.98Hz		

Input	Switcher	Output
1080p 60Hz (A or B)	1080p 60Hz (A)	1080p 60Hz (A)
1080i 60Hz		1080i 60Hz
720p 60Hz		720p 60Hz
1080p 59.94Hz (A or B)	1080p 59.94Hz (A)	1080p 59.94Hz (A)
1080i 59.94Hz <sup>1</sup>		1080i 59.94Hz
720p 59.94Hz		720p 59.94Hz
1080p 50Hz (A or B)	1080p 50Hz (A)	1080p 50Hz (A)
1080i 50Hz <sup>1</sup>		1080i 50Hz
720p 50Hz		720p 50Hz
1080p 30Hz	1080p 30Hz <sup>4</sup>	1080p 30Hz
1080p 29.97Hz	1080p 29.97Hz	1080p 29.97Hz
1080p 59.94Hz (A or B) <sup>2</sup>		
1080p 25Hz	1080p 25Hz	1080p 25Hz
1080p 50Hz (A or B) <sup>2</sup>		
1080p 24Hz	1080p 24Hz <sup>4</sup>	1080p 24Hz
1080p 23.98Hz	1080p 23.98Hz <sup>4</sup>	1080p 23.98Hz
1080pSF 29.97Hz	1080pSF 29.97Hz <sup>4</sup>	1080pSF 29.97Hz
1080pSF 25Hz	1080pSF 25Hz <sup>4</sup>	1080pSF 25Hz
1080pSF 24Hz	1080pSF 24Hz <sup>4</sup>	1080pSF 24Hz
1080pSF 23.98Hz	1080pSF 23.98Hz <sup>4</sup>	1080pSF 23.98Hz
1080i 59.94Hz	1080i 59.94Hz	1080i 59.94Hz
1080p 59.94Hz (A or B)		1080p 59.94Hz
720p 59.94Hz		
480i 59.94Hz		480i 59.94Hz
1080i 50Hz	1080i 50Hz	1080i 50Hz
1080p 50Hz (A or B)		1080p 50Hz (A)
720p 50Hz		720p 50Hz
576i 50Hz		576i 50Hz
720p 59.94Hz	720p 59.94Hz	720p 59.94Hz
1080p 59.94Hz (A or B)		1080p 59.94Hz (A)
720p 50Hz	720p 50Hz	720p 50Hz
1080p 50Hz (A or B)		1080p 50Hz (A)

Input	Switcher	Output
576i 50Hz	576i 50Hz	576i 50Hz
1080p 50Hz (A or B)		
1080i 50Hz		1080i 50Hz
720p 50Hz		
480i 59.94Hz	480i 59.94Hz	480i 59.94Hz
1080p 59.94Hz (A or B)		
1080i 59.94Hz		1080i 59.94Hz
720p 59.94Hz		

### Notes

- <sup>1</sup> Converted using either a simple line-doubler or 4-line interpolater and may result in lower quality video.
- <sup>2</sup> Converted by dropping frames and may result in lower quality video.
- <sup>3</sup> Only inputs 3-6 and 8-11 support Quad 3Gb/s or 1.5Gb/s UHDTV1 video.
- <sup>4</sup> Conversion is not supported when the switcher is operating in this video format.

## Input FSFC

Assign an FSFC to an input and then set up how the FSFC is used on the input.

### To Assign an FSFC to an Input (UHDTV1 Only)

You must assign an FSFC to an input to convert the input video. The CUF-ADD-I/OPLUS option provides additional resources.

1. Click **Navigation Menu > Configuration > Reference**.



2. In the **Input FSFC Assignment** area, click the **Input FSFC X** button for the FSFC you want to use.
3. Click the **Input** button to select the video input that you want to assign the FSFC to.

**Tip:** Click **Off** to take the FSFC out of the video path for the selected input.

### To Set Up an Input FSFC (SD or HD Only)

In SD or HD, configure the FSFC that has been assigned to the input. The conversion that is available depends on the format the switcher is operating in and the input that is being converted.

**Note:** If you do not have the CUF-ADD-I/OPLUS option activated, an I/O Processor must be assigned to the input first.

1. Click **Navigation Menu > Configuration > Inputs > External**.
2. Click the **Configure** button for the input you want to assign an FSFC to.



3. Click a **Type** button to turn on the FSFC.
  - **SDI** — no FSFC is applied to the input.
  - **SDI-FS** — an FSFC is applied to the input.
  - **QuadFS** — a timed FSFC is applied to the input. Each QuadFS is timed to the first SDI-FS in the group of four (1-4, 5-8, 9-12). The SDI-FS must be applied to the first input and QuadFS to the rest of the inputs in the group.

**Tip:** Use this if you are taking the quad-split output from an untimed UHD camera that you need to frame-sync. The frame syncs applied to each input are locked together for timing so that all four inputs are in sync.

4. If required, select the aspect ratio conversion mode you want to use. The options that are available depend on the video format that the switcher is converting from and to.
  - **Full** — The video signal is scaled disproportionately to fill the display of the new aspect ratio. Aspect distortion occurs as the image is stretched/compressed to fit in the new aspect ratio.
  - **Zoom** — The central portion of the video signal is zoomed to fill the display of the new video format. No aspect distortion is introduced but the edges of the video signal may be cropped.
  - **Letter Box** — Black bars are added to the top and bottom of a 16:9 image to display correctly in a 4:3 video format.

- **Pillar Box** — Black bars are added to the right and left of a 4:3 image to display correctly in a 16:9 video format.

### To Set Up an Input FSFC (UHDTV1 Only)

Set up the FSFC that has been assigned to the input. The conversion that is available depends on the format the switcher is operating in and the input that is being converted.

**Note:** You must assign an FSFC to the input before you can set it up.

1. Click **Navigation Menu > Configuration > Inputs > External**.
2. Click the **Configure** button for the input you want to set up the FSFC for.



3. Click a **Scaler** button to select the type of format conversion you want to apply to the input.
  - **12G-SDI** — no conversion is applied to the input (single-link 12Gb/s UHD-2SI).
  - **Q2SI**(input 3 and 8 only) — the input is converted from quad-link 3Gb/s UHD-2SI.
  - **QSD**(input 3 and 8 only) — the input is converted from quad-link 3Gb/s UHD-QSD.
  - **1080p** — the input is converted from 1080p.
  - **1080i** — the input is converted from 1080i.
  - **720p** — the input is converted from 720p.

4. Click **Frame Sync** to apply a frame synchroniser to the input.

**Note:** If a frame delay has been applied to the selected input, the frame sync functionality is disabled.

## Output FSFC

Assign an format converter to an output and then set up how the FC is used on the output.

### To Assign an FC to an Output (UHDTV1 Only)

You must assign an format converter (FC) to an output to convert the output video. The CUF-ADD-I/OPLUS option provides additional resources.

**Note:** Only outputs 5 to 14 support output conversion.

1. Click **Navigation Menu > Configuration > Reference**.



2. In the **Output FC Assignment** area, click an **Output FC X** button for the FC you want to use.
3. Click an **Output** button to select the video output that you want to assign the FC to.

**Tip:** Click **Off** to take the FC out of the video path for the selected input.

### To Set Up an Output FSFC (SD or HD)

In SD or HD, an I/O Processor can be assigned as an FSFC to an output. If you do not have the CUF-ADD-I/OPLUS option activated, an I/O Processor must be assigned to the output first.

**Note:** Only outputs 5 to 14 support output FSFC conversion. An I/O Processor must be assigned to the output.

**Note:** In the HD SRC 4 Key or HD SRC 6 Key mode, only outputs 5 and 6 support FC.

1. Click **Navigation Menu > Configuration > Outputs**.
2. Click the **Conversion** button for the output you want to convert.

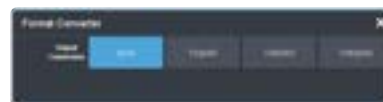

3. Click an **Output Conversion** button for the format you want to feed out of the selected output.
4. If required, select the aspect ratio conversion mode you want to use.

The options that are available depend on the video format that the switcher is converting from and to.

- **Full** — The video signal is scaled disproportionately to fill the display of the new aspect ratio. Aspect distortion occurs as the image is stretched/compressed to fit in the new aspect ratio.

- **Zoom** — The central portion of the video signal is zoomed to fill the display of the new video format. No aspect distortion is introduced but the edges of the video signal may be cropped.
- **Letter Box** — Black bars are added to the top and bottom of a 16:9 image to display correctly in a 4:3 video format.
- **Pillar Box** — Black bars are added to the right and left of a 4:3 image to display correctly in a 16:9 video format.

### To Set Up an Output FC (UHDTV1)

Set up the format converter (FC) that has been assigned to the output. The conversion that is available depends on the format the switcher is operating in and the input that is being converted.

**Note:** Only outputs 5 to 14 support output conversion.

1. Click **Navigation Menu > Configuration > Outputs**.
2. Click the **Conversion** button for the output you want to convert.



3. Click an **Output Conversion** button for the format you want to feed out of the selected output.
  - **12G-SDI** — no conversion is applied to the output (single-link 12Gb/s UHD-2SI).
  - **1080p** — the output is converted to 1080p.
  - **1080i** — the output is converted to 1080i.
  - **720p** — the output is converted to 720p.

## Aspect Ratio Conversion

Converting between standard-definition and high-definition video formats often requires converting between 4:3 and 16:9 aspect ratios. The switcher support Full, Zoom, Letterbox, and Pillarbox conversions.

In 480i and 576i video formats you can use either a 4:3 or 16:9 aspect ratio.

### Full

The video signal is scaled disproportionately to fill the display of the new aspect ratio. Aspect distortion occurs as the image is stretched/compressed to fit in the new aspect ratio.

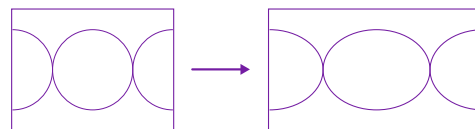

Figure 10: 4:3 to 16:9 Full Aspect Ratio Conversion

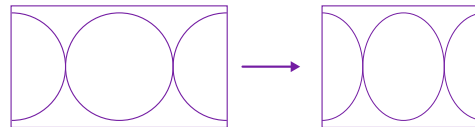

Figure 11: 16:9 to 4:3 Full Aspect Ratio Conversion

### Zoom

The central portion of the video signal is zoomed to fill the display of the new video format. No aspect distortion is introduced but the edges of the video signal may be cropped.

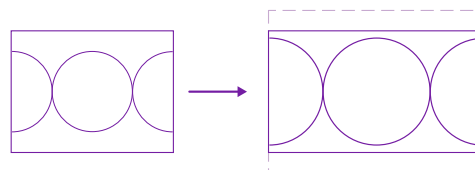

Figure 12: 4:3 to 16:9 Zoom Aspect Ratio Conversion

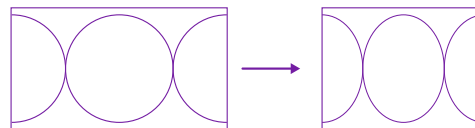

Figure 13: 16:9 to 4:3 Full Aspect Ratio Conversion

### Letterbox

Black bars are added to the top and bottom of a 16:9 image to display correctly in a 4:3 video format.

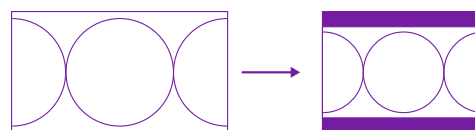

Figure 14: 16:9 to 4:3 Letterbox Aspect Ratio Conversion

### Pillarbox

Black bars are added to the right and left of a 4:3 image to display correctly in a 16:9 video format.

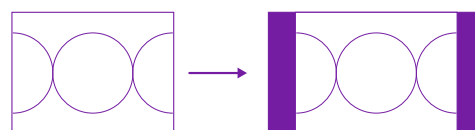

Figure 15: 4:3 to 16:9 Pillarbox Aspect Ratio Conversion

---

## Frame Delays (HD and UHDTV1 Only)

A delay of up to 13 frames in HD, or 7 frames in UHDTV1, can be added to any input that an FSFC is assigned to. This allows you to delay the timing of an input to compensate for the delay in another source. For example, in a virtual set environment it may take a few frames for the system to track the position of the camera and render the background. In this case you want to delay the foreground cameras to compensate for this delay.

*Note: The frame sync functionality is disabled when a frame delay is applied to an input.*

### To Apply a Frame Delay to an Input

Delay a video signal coming into the switcher in HD or UHDTV1.

*Note: An FSFC must be applied to the input you want to delay.*

1. Click **Navigation Menu > Configuration > Inputs > External**.
2. Click the **Configure** button for the input you want to apply a delay to.
3. Click **Delay**.



4. In the **Frame Delay** field enter the amount of delay to apply to the input.



---

# System Real-Time Clock/Date

The switcher uses an internal clock to generate the time for the clock overlay for the MultiViewer.

## To Set the System Real-Time Time and Date

1. Click **Navigation Menu > Configuration > System > Global**.
2. Click **Edit Date and Time**.



3. Click on the **Date** field and select the current date.
4. Click on the **Time** field and select the current time.
5. Click **Save**.

# Audio Breakout Module Setup

The 1RU Audio Breakout Module (ABM) provides the audio inputs and outputs for the switcher. A video loop between the switcher and the 1RU Audio Breakout Module passes all audio signals.



**Important:** Ensure that Phantom Power is turned off for the Analog Input unless you are connecting a microphone that requires phantom power. Connecting the line out from an audio device to the analog input with phantom power on could damage the audio device and/or the 1RU Audio Breakout Module. For added safety, a TRS phone connector should be used for line in audio sources.

**Note:** Some TRS jack plug adapters may introduce bleed between the left and right channels.

**Note:** Support for the 1RU Audio Breakout Module is not available in UHDTV1 at this time.

The system must be set up for the number of 1RU Audio Breakout Modules you want to connect. Each ABM connects to different IN and OUT BNCs on the 4RU Integrated Production System.

**Table 4: ABM Cable Connections**

	FRAME IN	FRAME OUT
ABM 1	OUT 14	IN 24
ABM 2	OUT 13	IN 23
ABM 3	OUT 12	IN 22



**Note:** The Tally and GPIO ports on the ABM are not supported at this time.

## To Set Up Multiple 1RU Audio Breakout Modules

The system can support up to 3 1RU Audio Breakout Modules.

1. Click **Navigation Menu > Configuration > System > Global**.



2. Click a **Num RAVE ABMs** button to select the number of 1RU Audio Breakout Modules connected to the system.

---

## AES Audio Output

Audio sources from the audio mixer, clip player, and Media-Store can be sent out the AES outputs of the frame.

### To Assign Audio to an AES Output

Assign an audio source to one of the AES outputs on the frame.

1. Click **Navigation Menu > Configuration > Outputs**.
2. Click the **Source** button for the **AES X** output you want to assign an audio source to and select the Media-Store or MediaWipe you want to assign to it.



*Note: Not all options are available, depending on the video format the switcher is operating in.*

- **NoSrc** — no audio source is assigned to the AES output.
- **MX** — the audio from Media-Store *X* is assigned to the AES output.
- **MEXMW** — the audio from the MediaWipe on ME *X* is assigned to the AES output.
- **ClipPlyr** — clip player audio.
- **Main** — the main mix stream from the audio mixer.
- **AuxX** — the aux mix *X* stream from the audio mixer.
- **Monitor** — the monitor mix stream from the audio mixer.

## Color Correction

The color correctors can operate as Processing Amplifiers (Proc Amps) in the HSL (Y-Cr-Cb) color space or as RGB Color Correctors in the RGB color space. Proc Amps and RGB Color Correctors apply color correction to video on input to the switcher, before the crosspoint, and on the output from the switcher. Correction applied to the input video is then available to all MEs. Output based correction is only available on output BNCs 5 to 14.

The total number of color correctors can be increased to 34 (7 in UHDTV1) with the activation of the Extra SD or HD I/O Processor option.

Color correction is additive, allowing you to apply any combination of Proc Amp and RGB Color Corrector based adjustment to a video signal. If multiple color corrections are applied, the correction is applied first, and the bus-based correction is applied after that.

### To Assign a Color Corrector to a Source (UHDTV1 Only)

You must assign a color corrector to an input or output to correct the color of the video.

1. Click **Navigation Menu > Configuration > Reference**.



2. In the **ProcAmp + Color Corrector/Converter Assignment** area, click the **PA/CC X** button for the color corrector you want to use.
3. Click an **Input/Output** button to select the video source that you want to assign the color corrector to.

**Tip:** Click **Off** to take the color corrector out of the video path for the selected input.

### Proc Amp Color Correction

The Proc Amp video correction allows you to adjust the gain, offset, black level, and gamma of the video signal.

### To Apply a Proc Amp to a Video Source

A Processing Amplifier (Proc Amp) applies color correction in the HSL (Y-Cr-Cb) color space for switcher sources.

**Note:** Only outputs 5 to 14 support output color correction.

1. Click **Navigation Menu > Configuration > ProcAmps > ProcAmp**.
2. Click the source button at the bottom left of the page and select the video you want to apply the Proc Amp to.



**Tip:** If correction has already been applied (**ON**), press **Reset** to return the Proc Amp and Color Correctors to the default values.

3. Click an **Enable** button to turn the Proc Amp on (**On**) for the selected video.



4. Use the sliders to adjust the video source.

Item	Description
<b>Chroma Gain</b>	Adjust the chrominance gain only.
<b>Luma Gain</b>	Adjust the luminance gain only.
<b>Hue Rotation</b>	Adjust the Hue. Increasing the Hue Rotation turns the color wheel clockwise, and decreasing the Hue Rotation turns the color wheel counter-clockwise.
<b>Black Level</b>	Adjust the black level. Black level acts as a luminance offset.
<b>Gamma</b>	Adjust the luminance gamma value.
<b>Gamma Offset</b>	Adjust the luminance gamma offset.
<b>Cr Gain</b>	Adjust the gain of the Cr (red color difference).
<b>Cr Offset</b>	Adjust the offset of the Cr.
<b>Cb Gain</b>	Adjust the gain of the Cb (blue color difference).
<b>Cb Offset</b>	Adjust the offset of the Cb.

## RGB Color Correction

The RGB color correctors allow you to adjust the red, green, and blue component gain, offset, and gamma of the video signal.

### To Apply RGB Color Correction to a Video Source

An RGB Color Corrector applies color correction in the RGB color space for switcher sources.

**Note:** Only outputs 5 to 14 support output color correction.

1. Click **Navigation Menu > Configuration > ProcAmps > Color Correction**.
2. Click the source button at the bottom left of the page and select the video you want to apply the Color Corrector to.



**Tip:** If correction has already been applied (**ON**), press **Reset** to return the Proc Amp and Color Correctors to the default values.

3. Click an **Enable** button to turn the color corrector on (**On**) for the selected video input or output.



4. Click the **Component** button for the individual color component (**Red**, **Green**, **Blue**) you want to adjust, or **RGB** for all of them.
5. Use the sliders to adjust the color components.

**Tip:** Click a **Color Temperature** button to apply a temperature color correction to the video.

- **Gain** — adjust the gain of the component(s).
- **Offset** — adjust the offset of the component(s).
- **Lower Offset** — adjust the lower offset of the component(s).
- **Gamma** — adjust the gamma value of the component(s).
- **Gamma Offset** — adjust the gamma offset of the component(s).

## High Dynamic Range (HDR) and Wide Color Gamut (WCG) Conversion

The RGB color correctors are used to convert between different SDR and HDR ranges and between color gamuts (WCG).

**Note:** HDR and WCG input conversion can only be applied in HD and UHD switcher modes.

**Note:** You must have available color correctors to be able to perform the HDR/WCG conversion.

**Note:** Media items must be created in the same color gamut and dynamic range that they are intended to be used in on the switcher. If a media item is created in one color space and the switcher is operating in another, the media item may not appear correctly.

HDR and WCG conversion can be applied on the fly to input video signals or aux bus outputs.

**Tip:** You can use the RGB Color converter to convert between SDR and HLG1200 dynamic ranges.

To configure the dynamic range and color gamut conversion of input sources you must apply a color corrector to the input. This will convert the input source to the format that the switcher is operating in. Video signals can again be converted for individual output BNCs.

### Supported Color Gamuts:

- **BT.709** — color gamut recommended for HD video signals.
- **BT.2020** — wide color gamut recommended for UHD TV1 video signals.

### Supported Dynamic Ranges

- **SDR** — Standard Dynamic Range.
- **HLG** — Hybrid Log Gamma.
- **PQ** — Perceptual Quantizer.
- **S-Log3** — Sony® S-Log3.

### Supported HDR and WCG Conversion

The switcher supports both dynamic range and color gamut conversion.

**Note:** Round trip color conversion is not recommended. Converting a source from BT.709 to BT.2020 and then back to BT.709 will not precisely reproduce the original image colors again.

**Note:** The switcher uses the color correctors for conversion.

**Table 5: Supported HDR/Color Gamut Conversion**

Input	Supported Conversions
SDR BT.709	SDR BT.709
	SDR BT.2020
	HLG BT.2020
	PQ BT.2020
	S-Log3 BT.2020
HLG BT.709	HLG BT.709
PQ BT.709	PQ BT.709
S-Log3 BT.709	S-Log3 BT.709
SDR BT.2020	SDR BT.2020
	SDR BT.709
	HLG BT.2020
	PQ BT.2020
	S-Log3 BT.2020
HLG BT.2020	SDR BT.2020
	SDR BT.709
	HLG BT.2020
	PQ BT.2020
	S-Log3 BT.2020
PQ BT.2020	SDR BT.2020
	SDR BT.709
	HLG BT.2020
	PQ BT.2020
	S-Log3 BT.2020
S-Log3 BT.2020	SDR BT.2020
	SDR BT.709
	HLG BT.2020
	PQ BT.2020
	S-Log3 BT.2020

### To Set the Switcher Dynamic Range and Color Gamut

To properly convert input and output video sources you must set the color gamut and dynamic range that the switcher is operating in. These are the dynamic range and color gamut settings that inputs are converted to and outputs are converted from.

**Note:** The switcher must be operating in an HD or UHD switcher mode for dynamic range and color gamut conversion.

1. Click **Navigation Menu > Configuration > Reference.**



2. Click a **Dynamic Range** button to select the range you want the switcher to operate in.
  - **SDR** — Standard Dynamic Range.
  - **HLG** — Hybrid Log Gamma.
  - **PQ** — Perceptual Quantizer.
  - **SLOG3** — Sony® S-Log3.
3. Click a **Color Gamut** button to select the color gamut you want the switcher to operate in.
  - **BT.709 (HD)** — color gamut recommended for HD video signals.
  - **BT.2020 (UHD)** — wide color gamut recommended for UHDTV1 video signals.

### To Set the Video Input Dynamic Range and Color Gamut

You must assign the dynamic range and color gamut of input video for that source to be converted.

**Note:** You must assign a color corrector to the input to be able to convert it.

1. Click **Navigation Menu > Configuration > Inputs > External.**



2. Click the **Dyn. Range** button for the video input that needs to be converted and select the dynamic range of the input video signal.

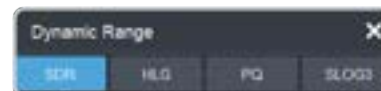

- **SDR** — Standard Dynamic Range.
- **HLG** — Hybrid Log Gamma.
- **PQ** — Perceptual Quantizer.
- **SLOG3** — Sony® S-Log3.

3. Click the **Color Gamut** button for the video input that needs to be converted and select the color gamut of the input video signal.

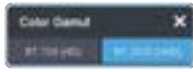

- **BT.709 (HD)** — color gamut recommended for HD video signals.
- **BT.2020 (UHD)** — wide color gamut recommended for UHD TV1 video signals.

### To Set the Video Output Dynamic Range and Color Gamut

You must assign the dynamic range and color gamut of output video for that source to be converted.

*Note:* You must assign a color corrector to the output to be able to convert it.

1. Click **Navigation Menu > Configuration > Outputs.**



2. Click the **Dyn. Range** button for the video output that needs to be converted and select the dynamic range for the output video signal.

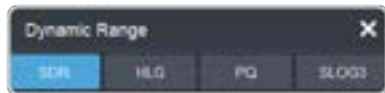

- **SDR** — Standard Dynamic Range.
  - **HLG** — Hybrid Log Gamma.
  - **PQ** — Perceptual Quantizer.
  - **SLOG3** — Sony® S-Log3.
3. Click the **Color Gamut** button for the video output that needs to be converted and select the color gamut for the output video signal.

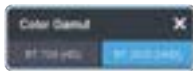

- **BT.709 (HD)** — color gamut recommended for HD video signals.
- **BT.2020 (UHD)** — wide color gamut recommended for UHD TV1 video signals.

# Personality

Personality settings allow you to configure how you interact with the control panel and switcher, as well as how the buttons on the control panel appear. All of these settings are stored in the Personality register.

## Personality Settings

There are a number of settings for how the switcher will react to different situations, or how switcher elements appear to the operator. All these settings are grouped together into the Switcher Personality. These settings include double-press rates and sleep time, among others.

### General Settings

- Click **Navigation Menu > Personality > General**.



Personality	Description
<b>Editor Port</b>	Allow the switcher to be controlled by an external editor. The external editor can control the switcher to perform transitions, or recall memories, among the supported commands. This setting is for the frame. <ul style="list-style-type: none"> <li><b>On</b> — allow the switcher to be controlled by an external editor.</li> <li><b>Off</b> — switcher ignores editor commands.</li> </ul>
<b>Button Brightness</b>	Set the overall brightness (0-100%) of all the buttons on any physical control panel connected to the switcher. This setting is unique to the control panel.
<b>Rate</b>	Have the switcher use frames or seconds for transition rates. Rates are entered and displayed in the select selected values. This setting is unique to the control panel. <ul style="list-style-type: none"> <li><b>Frames</b> — transition rates are in frames.</li> <li><b>Seconds</b> — transition rates are in seconds.</li> </ul>

Personality	Description
<b>Sleep Mode</b>	have the switcher go into a sleep mode after a user-defined amount of time ( <b>Sleep Minutes</b> ) without user interaction. Touching any button, knob, or fader will wake the switcher. The switcher does not act on the button, knob, or fader control that wakes it from sleep mode. During sleep mode, video related hardware is not affected and video signals still pass through the switcher. This setting is unique to the control panel. <ul style="list-style-type: none"> <li><b>Power Save</b> — all buttons and displays are turned off and as much power is conserved as possible.</li> <li><b>Sleep</b> — displays are turned off and buttons light in raindrop pattern.</li> </ul>
<b>Sleep Minutes</b>	The amount of time that the switcher waits without user input before going into sleep mode. Setting the value to 0 (Off) prevents the switcher from entering sleep mode. This setting is unique to the control panel.
<b>Toggle Shift</b>	Have the <b>Shift</b> buttons either be latching (toggle) or momentary (off). When in toggle mode, you can press a shift button and then select a source on the shifted bus without having to hold down the shift button. This only affects the bus the shift button is on. This setting is unique to the control panel. <ul style="list-style-type: none"> <li><b>Off</b> — <b>Shift</b> buttons only stay on as long as you are holding them down.</li> <li><b>Toggle</b> — when you press a <b>Shift</b> button it stays on until you press a source button on that bus.</li> </ul>
<b>Memory Bank</b>	Allows you to set how the <b>BANK</b> button behaves when pressed and released. This setting is unique to the control panel. <ul style="list-style-type: none"> <li><b>Normal</b> — the keypad is used to enter the bank number directly, followed by the memory (For example, to access memory 3 on bank 2, press <b>BANK &gt; 2 &gt; 3</b>.)</li> <li><b>Legacy</b> — the next bank is selected every time the button is pressed, cycling through all banks (For example, to access bank 5, press <b>BANK</b> repeatedly until bank 5 is selected.)</li> </ul>
<b>Memory Undo</b>	A memory recall can be reversed by pressing the memory number a second time after a memory is recalled. This is the same as pressing the <b>UNDO</b> button, if present on your control panel. This setting is unique to the control panel. <ul style="list-style-type: none"> <li><b>Off</b> — pressing the memory number again does not undo the recall.</li> <li><b>On</b> — pressing the memory number again undoes the last memory recall.</li> </ul>



Personality	Description
<b>CC Mnemonic Row</b>	<p>How you want the mnemonics on each panel row to display the mnemonics for custom controls.</p> <ul style="list-style-type: none"> <li>• <b>Off</b> — the mnemonics don't change when the row is assigned to a custom control bank.</li> <li>• <b>Split</b> — the mnemonics are split (top to cc name and bottom to bus sources) when the row is assigned to a custom control bank.</li> <li>• <b>Full</b> — the mnemonics are show only the names of the custom controls when the row is assigned to a custom control bank.</li> </ul>

## Transition Settings

- Click **Navigation Menu > Personality > Transition**.



Personality	Description
<b>Transition</b>	<p>Have the next transition reset to a default background dissolve after each transition. This allows you to prevent the selections from the last transition from being accidentally included with the next transition. This setting is for the frame.</p> <ul style="list-style-type: none"> <li>• <b>No Reset</b> — the next transition settings are not changed after a transition.</li> <li>• <b>Reset</b> — the next transition is reset to a background only transition after a transition.</li> </ul>
<b>Next Transition</b>	<p>Have the next transition buttons on the control panel latch when pressed (toggle). This setting is unique to the control panel.</p> <ul style="list-style-type: none"> <li>• <b>Off</b> — press and hold all the buttons you want included in the next transition. All buttons must be pressed at the same time.</li> <li>• <b>Toggle</b> — press a button to toggle it on or off as being included in the next transition.</li> </ul>

Personality	Description
<b>Remove Keys</b>	<p>Have a key removed from the next transition after it has been transitioned off-air using key Cut or Trans buttons. This allows you to transition a key off-air in an emergency and not have it accidentally transitioned back on-air with the next transition. This setting is for the frame.</p> <ul style="list-style-type: none"> <li>• <b>Off</b> — key can remain part of the next transition when it is independently transitioned off-air.</li> <li>• <b>On</b> — key is removed as part of the next transition when it is independently transitioned off-air.</li> </ul>
<b>Background Double Press</b>	<p>Have a double-press of the next transition background button select the background and all on-air keys as part of the next transition. This setting is unique to the control panel.</p> <ul style="list-style-type: none"> <li>• <b>Ignore</b> — ignore the double-press of the next transition background button.</li> <li>• <b>Transition Clear</b> — set the next transition to include the background and only the on-air keys. If an off-key is selected as part of the next transition it is deselected.</li> </ul>
<b>ME Auto Trans Double Press</b>	<p>Set what action is performed when the auto transition button is pressed again during a transition. This setting is for the frame.</p> <ul style="list-style-type: none"> <li>• <b>Halt Forward</b> — the transition is halted and then continues in the same direction when the transition button is pressed again.</li> <li>• <b>Reverse</b> — the transition immediately reverses directions when the transition button is pressed.</li> <li>• <b>Halt Reverse</b> — the transition is halted and then reverses directions when the transition button is pressed again.</li> <li>• <b>Cut</b> — the transition immediately cuts back to the initial state when the transition button is pressed.</li> <li>• <b>Ignore</b> — the button press is ignored and the transition continues.</li> </ul>

Personality	Description
<b>Key Auto Trans Double Press</b>	<p>Set what action is performed when the independent key auto transition button is pressed again during a transition. This setting is for the frame.</p> <ul style="list-style-type: none"> <li>• <b>Halt Forward</b> — the transition is halted and then continues in the same direction when the transition button is pressed again.</li> <li>• <b>Reverse</b> — the transition immediately reverses directions when the transition button is pressed.</li> <li>• <b>Halt Reverse</b> — the transition is halted and then reverses directions when the transition button is pressed again.</li> <li>• <b>Cut</b> — the transition immediately cuts back to the initial state when the transition button is pressed.</li> <li>• <b>Ignore</b> — the button press is ignored and the transition continues.</li> </ul>
<b>Roll Clip</b>	<p>Set whether the roll clip feature is always on, or must be turned on manually. This setting is for the frame.</p> <ul style="list-style-type: none"> <li>• <b>User</b> — the roll clip feature must be turned on manually.</li> <li>• <b>Force</b> — the roll clip feature is always on.</li> </ul>

## Color Schemes

The buttons on the control panel glow with different colors specific to their state, function, and assignment. This color can be selected from a list of pre-set color schemes, or a custom color can be selected. Up to four (4) custom color schemes can be saved on the switcher.

### To Select a Color Scheme

ME, MiniME™, Canvas, aux buses, and keyers can be set to different colors by loading one of the pre-installed color scheme. This setting is unique to the control panel.

1. Click **Navigation Menu > Personality > Color Scheme**.



2. In the **Load Scheme** area, select the color scheme you want to use on the control panel.

*Tip: You can load a pre-loaded color scheme and then modify the colors and save it as a custom color scheme. You cannot save your modifications back to the pre-loaded color scheme.*

### To Create a Custom Color Scheme

A custom color scheme can be created and used instead of one of the pre-loaded color schemes. This setting is unique to the control panel.

1. Click **Navigation Menu > Personality > Color Scheme**.



2. In the **Modify Scheme** area, click the ME, MiniME™, Canvas, or aux that you want to change the color for.

*Tip: Click **Change All** to change the color of all the areas at once. They will all use the selected color.*

3. Use the color picker to select the new color you want to use and click **Ok**.



*Tip: Click **Live** to have the color changes update in real time on the control panel.*

4. In the **Unique Key Color** area select how you want the keyer buttons on the control panel to be colored.
  - **Off** — the keyer buttons use the same color as their ME, MiniME™, or Canvas.
  - **On** — the keyer buttons use the unique colors assigned to each key. Click the key that you want to change the color for and use the color picker to change the color.
5. Click a **Custom X** button to store your color scheme to that location.
6. Click **Yes**.

## Bus Maps

Any video input can be mapped to any source button on the control panel using a bus map. Each source button can have multiple inputs

assigned (a main source and shifted sources). You can have up to 6 shifted buses.

## To Create a Bus Map

The bus map assigns video sources to the buttons on the control panel.

**Note:** The bus map is unique to the control panel (Main, Sat 1, Sat 2, or Sat 3) and can only be set for that control panel.

1. Click **Navigation Menu > Personality > Bus Map**.



2. Depending on the size of your panel, click a **Buttons X-Y** button to view the source buttons in that range.
3. Click the source button you want to use for a Shift function and click **Other** and select the shift level you want to assign to that source button.



**Note:** You can have up to 6 shifted buses. All Shift buttons must be assigned to the **Main** bus.

**Tip:** You can rename the shift button, and other internal sources, from the **Internal Input Configuration** menu.

4. Click the source button on the main or shifted bus that you want to assign a source to and select the source you want to assign to that button.

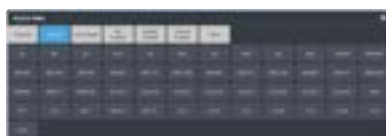

**Note:** The sources that are available on your switcher may differ depending on the options you have installed and how your switcher is configured.

## User Buttons

These buttons can be assigned to a number of functions, including ME and key selections, custom control, and memories. The number and position of the buttons on the control panel depend on the model of your control panel.

If a button is assigned to an ME, aux bus, MiniME™, Canvas, or chroma key, you can press and hold the button to be able to select a different ME, aux bus, MiniME™, Canvas, or chroma key from the key bus. If the user button is assigned to an Aux, it will allow you to select a different Aux.

## To Set A User Button

1. Click **Navigation Menu > Personality > User Select**.

**Note:** The menu only shows the user buttons that are available on your control panel.



2. Click the user button that you want to assign a function to and select the function you want to assign to that button.

**Tip:** Each row on your control panel can have a separate set of user button assignment. These settings are tied to the row, and not the ME that is assigned to that row.

**Tip:** The **Trans** buttons are located on the Transition area of the TouchDrive control panel.



**Note:** The functions that are available on your switcher may differ depending on the options you have installed and how your switcher is configured.

---

## Licenses

The switcher comes with all the hardware required for the available options. These options can either be licensed at the time you purchase your switcher, or purchased and installed later on.

**Note:** Some options can utilize external equipment that must be purchased separately (control panels or 1RU Audio Breakout Module for example).

### To Add a License

The license menu lists the options that are installed, as well as allows you to copy and paste codes for installing new options.

1. Contact your Ross Video sales representative to purchase a license for the option you want to install.
  - **CUF-ADD-ME2** — add second SD or HD ME.
  - **CUF-ADD-ME3** — add third SD or HD ME.
  - **CUF-UHD-ADD-ME1-LIC** — add first UHDTV1 ME.
  - **CUF-UHD-ADD-ME2-LIC** — add second UHDTV1 ME.
  - **CUF-ADD-I/OPLUS** — upgrade to 34 SD or HD I/O Processors
  - **CUF-UHD-ADD-I/OPLUS-LIC** — upgrade to 7 UHDTV1 input FSFCs and 4 output FCs.
  - **CUF-ADD-MV2&4** — add I/O MultiViewer to output 2 and Video Processor MultiViewer output 4.
  - **CUF-UHD-ADD-MV-LIC** — add I/O MultiViewer to output 1.
  - **CUF-RAVE-AUDIO** — add the RAVE audio mixer.

**Tip:** You can also email ([solutions@rossvideo.com](mailto:solutions@rossvideo.com)) or call (+1-613-652-4886) for sales options.

2. Click **Navigation Menu > Configuration > System > Licenses**.



3. Click the **Request Code Copy** button for the option type(s) you have purchased.

4. Send the **Request Codes** to the Ross Video contact you were given when you purchased the options and they will send you the **License Keys** for the options.

5. Click the **License Key Paste** button to paste the key into the field.

**Note:** If you paste the license key into the field using a keyboard, you must click away from the field for the key to be validated and the **Apply** button to function.

6. Click **Apply**.

7. Power cycle the frame by switching the power button **Off** and then **On** again.

The switcher will come up with the new software options activated.

# GPI Control

General Purpose Interface (GPI) is a high/low voltage signalling protocol that allows the switcher to send simple commands to an external device, or receive commands from a device. Each pin on the GPI is set as either high (+5 Volts), or low (0 Volts), and it is the switching between high and low that sends commands to the external device, or to the switcher.

Refer to [GPI Device Control](#) on page 96 for information on assigning a GPI to a video input.

## GPI Trigger Types

There are four trigger types supported by the switcher. These can be either output triggers, or input triggers.

**Table 6: Trigger Types**

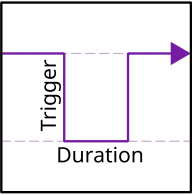
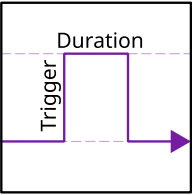
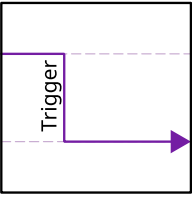
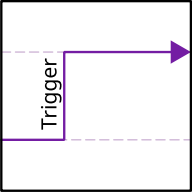
Trigger	Description	
Low Edge	The output level is set high, and momentarily goes low for the trigger.	
High Edge	The output level is set low, and momentarily goes high for the trigger.	
Low Level	The output level toggles from the base high level to the low level. The output signal remains at this level until reset.	
High Level	The output toggles from the base low level to the high level. The output signal remains at this level until reset.	

## GPI Setup

Each GPI pin on the switcher can be configured as either an input, or an output. By default, all GPIs are set as inputs.

### Keep the following in mind:

Keep the following in mind when working with GPI output triggers:

- Edge triggered GPI outputs remain triggered for the configured duration.
- Level triggered GPI outputs toggle between high and low each time they are triggered.

### To Set Up a GPI Input

The switcher requires a Low Edge GPI input trigger.

1. Click **Navigation Menu > Configuration > Tally and GPIO > GPIO.**



2. Click **Edit** for the GPI that you want to configure as an input.

3. Click **GPI.**



4. Click the **Event** button for the action you want to assign to the selected GPI input pin.

Setting	Description
--none--	No action is taken
CC	Run a specific custom control: <ol style="list-style-type: none"> <li>Enter the custom control bank in the <b>Bank</b> field.</li> <li>Enter the custom control in the <b>CC</b> field.</li> </ol>
Mem Recall	Recall a memory on all MEs: <ul style="list-style-type: none"> <li>Enter the memory to recall in the <b>Mem</b> field.</li> </ul>
UltraScene	Recall an UltraScene memory: <ul style="list-style-type: none"> <li>Enter the UltraScene memory to recall in the <b>UltraScene</b> field.</li> </ul>
FTB	Perform a transition to black on the program ME that also takes all keys off-air. The source originally selected on program is selected on preset
ME Cut	Perform a background cut on the selected ME: <ul style="list-style-type: none"> <li>Click an <b>ME</b> button to select the ME, MiniME™, or Canvas.</li> </ul>

Setting	Description
<b>ME Auto</b>	Perform a background auto transition on the selected ME: <ul style="list-style-type: none"> <li>Click an <b>ME</b> button to select the ME, MiniME™, or Canvas.</li> </ul>
<b>Key Cut</b>	Perform a key cut on the selected ME and key: <ol style="list-style-type: none"> <li>Click an <b>ME</b> button to select the ME, MiniME™, or Canvas.</li> <li>Click a <b>Key</b> button to select the keyer.</li> </ol>
<b>Key Auto</b>	Perform a key auto transition on the selected ME, MiniME™, or Canvas and key: <ol style="list-style-type: none"> <li>Click an <b>ME</b> button to select the ME, MiniME™, or Canvas.</li> <li>Click a <b>Key</b> to select the keyer number.</li> </ol>
<b>Aux Xpt</b>	Select a video source on an aux bus: <ol style="list-style-type: none"> <li>Click the <b>Aux</b> button and select the aux bus.</li> <li>Click the <b>Source</b> button and select the video source.</li> </ol>

- Click a **Trigger** button to select whether you want to use an edge trigger (**Edge**), or a level trigger (**Level**).
- For edge triggers, use the **Duration (fr)** slider to set the length of time (in frames) that the GPI edge output remains triggered.
- For level triggers, click a **Mode** button to select how you want to GPI output to act.
  - Normal** — when assigned to a video source and RollClip is active, will trigger with the source going on-air, and back with the source going off-air (pre-delay values are only used when the source is going on-air)
  - Tally** — when assigned to a video source, will trigger with the source going on-air, and back with the source going off-air (RollClip and pre-delay values are ignored)

## To Set Up a GPI Output

A GPI output can be set as a Normal GPI output, or as a Tally output. As a tally output, the GPI output must be assigned to a video source. A GPI output in tally mode can still be used as a normal GPI output.

- Click **Navigation Menu > Configuration > Tally and GPIO > GPIO**.

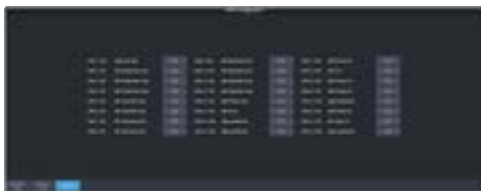

- Click **Edit** for the GPI that you want to configure as an output.
- Click **GPO**.



- Click a **Level** button to select whether you want the GPI to trigger low (**Low**), or high (**High**).

# Live Edit Decision Lists (LiveEDL)

Edit Decision Lists are files used by non-linear editing (NLE) suites to aid in post-production. Your switcher can capture EDL data in a file that you load into your NLE suite.

## LiveEDL Setup

You can configure your switcher to trigger multiple GPI outputs at the start, end, or both, of an EDL data capture to trigger video servers that are recording the feeds coming into the switcher. The EDL data from the switcher can then be paired with the feeds from the video servers, using the timecode data, in the NLE suite to edit or re-cut the show.



**Important:** A control panel is required to configure this feature. If you do not have access to a physical control panel, the SoftPanel can be used.

You can configure your switcher to trigger multiple GPI outputs at the start, end, or both, of an EDL data capture to trigger video servers that are recording the feeds coming into the switcher. The EDL data from the switcher can then be paired with the feeds from the video servers, using the timecode data, in the NLE suite to edit or re-cut the show.

You can also set a pre-delay for each GPI output. EDL data capture does not begin until the highest pre-delay has passed. This is useful when the switcher needs to wait for external equipment to become ready. The example below shows the effects of various triggering and pre-delay settings.

### To Set the LiveEDL Behavior



**Important:** A control panel is required to perform this procedure. If you do not have access to a physical control panel, the SoftPanel can be used. The position of items on the menus on the SoftPanel may not match those of a physical panel.

1. Press **MENU > System > NEXT > NEXT > NEXT > LiveEDL Config**.
2. Use the **GPO** knob to select the GPI output that is connected to your video server.  
The GPI must be configured as a GPI output before it can be selected.
3. Use the **Triggr** knob to select when the GPI output is triggered.

- **Off** — GPI is not triggered
- **Start** — GPI output is triggered at the beginning of the EDL capture
- **Stop** — GPI output is triggered at the end of the EDL capture
- **Both** — GPI output is triggered at the beginning and end of the EDL capture

If Start or Both is selected, you must set the pre-delay for the GPI.

4. Use the **PreDly** knob to select the pre-delay interval (in frames) that the switcher waits after the GPI output is triggered before starting to capture EDL data.

## Timecode Setup

The switcher uses timecode data to mark the EDL file so that it can be used in the non-linear editing suite along with the feeds from the video servers. The timecode data can be either from an external timecode generator, or internally generated. An offset can be applied to both timecode sources.

For an external timecode, an LTC generator must be connected to the LTC port on the back of the frame.

### To Confirm External LTC Signal

If you have an external linear timecode generator connected to the switcher, you can confirm that the switcher is receiving timecode data.



**Important:** A control panel is required to perform this procedure. If you do not have access to a physical control panel, the SoftPanel can be used. The position of items on the menus on the SoftPanel may not match those of a physical panel.

1. Click **Navigation Menu > Status**
2. Confirm that the information shown in the **Timecode** field matches the timecode from the timecode generator.

If required, an offset can be applied to the incoming timecode data.

### To Set Up Communications with a TSC-9902



**Important:** A control panel is required to perform this procedure. If you do not have access to a physical control panel, the SoftPanel can be used. The position of items on the menus on the SoftPanel may not match those of a physical panel.

1. Press **MENU > System > NEXT > NEXT > Device Configure**.
2. Press the **Add** knob.
3. Use the **Slot** knob to select **SP** (serial port).
4. Use the **Type** knob to select **LTC**.
5. Press **NEXT**.
6. Use the **SubType** knob to select **LTC\_#.#**.
7. Press the **SubType** knob.
8. Press the **Confirm** knob to save your settings.

### To Set the LTC Timecode Source

If you are using an external timecode generator, an offset, or delay, is applied to the incoming timecode signal before it is stored in the LiveEDL data file. If you are using an internal timecode, the offset is the starting time that the switcher uses for the timecode that is stored in the LiveEDL file.



**Important:** A control panel is required to perform this procedure. If you do not have access to a physical control panel, the SoftPanel can be used. The position of items on the menus on the SoftPanel may not match those of a physical panel.

**Note:** If a valid timecode signal is detected on the LTC port on the frame, the external timecode will be used even if an internal timecode is set.

1. Press **MENU > System > NEXT > NEXT > NEXT > LiveEDL Config > NEXT**.
2. Use the **Offset** knob to select the source of the timecode data you want to use.
  - **Ext.** — the timecode data received on the LTC port is used
  - **Int.** — an internal timecode is generated
3. Set the timecode offset for an External timecode as follows:
  - a) Use the **LTCOff** knob to select the offset, in frames, that you want to delay the incoming timecode signal by.
4. Set the starting time for an Internal timecode as follows:
  - a) Use the **Field** knob to select the hours, minutes, or seconds that you want to adjust.  
The timecode is shown in the [HH:MM:SS] format.
  - b) Use the **Value** knob to set the starting time in the selected field.

## LiveEDL Data Capture

Capturing EDL data is manually started and stopped from the switcher. When you select to start capturing EDL data, and GPI outputs set to trigger on start are triggered. If a pre-delay has been set for the GPIs, the switcher does not start capturing EDL data until the pre-delay time has finished.

When you stop capturing EDL data, you have the option to delete the data, or save it to a USB drive. You can also connect to the switcher via FTP and download the files directly to your editing suite. Use the username `liveedl` and password `password` to create the FTP connection to the switcher.

### Keep the following in mind:

Keep the following in mind when reviewing the EDL data from the switcher:

- When a MediaWipe is selected as the transition type, the switcher records the transition duration as the cut point frame multiplied by two (2). This is to ensure that the cut point is recorded accurately.
- If you used more than one ME, or Aux bus, in your shot, a separate EDL file is saved for each ME and Aux bus. The ME re-entry is shown as being selected on the first ME, and the source selections on the second ME are saved to the separate LiveEDL file.

### To Start Capturing EDL Data

The EDL data can be stored to one of 1000 LiveEDL files stored on the switcher. A separate file is created for each ME when the additional MEs are used.



**Important:** A control panel is required to perform this procedure. If you do not have access to a physical control panel, the SoftPanel can be used. The position of items on the menus on the SoftPanel may not match those of a physical panel.

1. Press **MENU > User > LiveEDL**.
2. Use the **Start** knob to select the LiveEDL file on the switcher that you want to store the EDL data to.  
If the LiveEDL file already contains data, you are given the option to delete the data, or save it to a USB.
3. Press the **Start** knob to start recording.



---

## To Stop Capturing and Save EDL Data



**Important:** A control panel is required to perform this procedure. If you do not have access to a physical control panel, the SoftPanel can be used. The position of items on the menus on the SoftPanel may not match those of a physical panel.

1. Press **MENU > User > LiveEDL**.
2. Press the **Stop** knob to stop recording.
3. Save the EDL data to a USB as follows:
  - a) Insert your USB drive into the USB Port on the switcher. You must wait 5 seconds for the switcher to recognise the USB drive.
  - b) Press the **Save** knob.
  - c) Press the **Confirm** knob to store the LiveEDL file to the USB drive.

# ViewControl (HD or UHD Only)

The ViewControl interface through DashBoard allows you to coordinate the control over the Carbonite switcher, XPression Live Graphics System, and the BlackStorm Playout Server all through a touchscreen interface. Through ViewControl you can select sources, perform transitions, and run custom controls.

### Keep the following in mind:

Keep the following in mind when working with ViewControl:

- ViewControl requires DashBoard 5.1, or later.
- Only the sources assigned to the MultiViewer boxes are available for direct selection. Custom controls can be used to select other sources.
- The control panel does not follow key and bus selections made on ViewControl.
- The MultiViewer Shift must be set to the main or satellite panel that the DashBoard you are using for ViewControl is assigned to.

## ViewControl Overview

The ViewControl interface provides quick access to a number of custom control buttons as well as the transition functionality of the switcher.

### Custom Control Buttons

The custom control buttons can be assigned to any custom control on the switcher and given unique names and icons. The button groups on the left (shown below) are organized into groups, or tabs. The buttons along the bottom are constant across all tabs.



### Bus Selection Buttons

The bus selection buttons allow you to select the different buses on different ME and MiniME™ outputs of the switcher.



### To Select a Source on a Bus

1. Click **ME PP** at the top and click the ME or MiniME™ that you want to select a bus on.

*Tip: If the Shift feature is active the Program and Preview boxes will switch to the selected ME or MiniME™.*

2. Click the bus you want to select a source on at the lower left.
3. Click on the source (MultiViewer box) that you want to assign to the selected bus.

*Tip: Click **Shift** to access the sources on the shifted MultiViewer boxes.*

### Keyer Transition Buttons

The Keyer Transition buttons allow you to perform a cut or dissolve of the keys on the selected ME or MiniME™. These buttons act the same as the Keyer Transition Buttons on the control panel.

*Tip: The Cut buttons tallies when a key is on. Red when the key is on-air or blue when it is on for an ME or MiniME™ that isn't on-air.*



### Transition Buttons

The transition buttons allow you to select what is included in the next transition, what type of transition is to be performed, and perform the transition. These buttons function similarly to

the buttons in the Transition Area on the control panel.



### To Perform a Transition

1. Click the **ME PP** button and select the ME or MiniME™ that you want to perform the transition on.
2. Click the **BKGD** and **Key** button over the Preview box to select what to include in the next transition.
3. Click **Diss**, **Wipe**, **DVE**, or **MW** to select the type of transition to perform.

*Tip: Live Assist will follow the selection to allow you to set the transition parameters.*

4. Click **Auto** to perform the transition, or **Cut** to perform a cut transition.

## Custom Control Button Setup

When you assign a custom control to a button, you can give that button a unique name and assign an icon to it. The images for the icons must be on a USB drive in the frame when you assign them. Once assigned the icons are stored in the frame and the USB can be removed. Each of the tabs can be named.

The configuration of the tabs and custom control assignment to buttons are stored with the switcher personality settings.

### To Set up the Custom Control Buttons

You must assign custom controls from the switcher to the buttons on ViewControl.

If you want to assign icons to the custom control buttons, you must have the images you want to use for the icons stored on a USB drive installed in the frame. After the images have been assigned you can remove the USB drive.

1. Click the  button.



2. Press the custom control button that you want to set up.
3. Enter a name for the button in the **Button Name** field.

*Tip: You can change the name of a tab by selecting a button on the tab and then entering a new name in the **Group Name** field.*

4. Click the **Bank** button and select the number of the bank you want to select a custom control from.
5. Click the **CC X** button and select the number of the custom control you want to assign to the button.
6. Navigate the files on the USB drive and click the image you want to assign as the icon for the button.

*Tip: Press **Default Icon** to switch back to the default icon.*

7. Set up additional custom control buttons as required.
8. Press **Save** when you are done setting up custom control buttons.

## ViewControl Setup

ViewControl can be set up to use either an external HDMI™ converter or a direct NDI® stream. The NDI® stream is only supported on specific MultiViewer layouts.

### Connecting ViewControl over HDMI™

ViewControl combines an overlay image from Dashboard with a custom MultiViewer output from the switcher to generate the interface. This requires some external SDI/HDMI video conversion equipment, as well as a touchscreen display.

*Note: An input FSFC should be applied to the input you are using for ViewControl.*

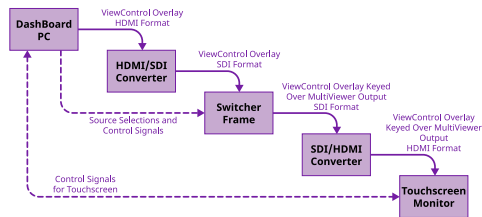

The following connections are required for ViewControl:

- ViewControl is only supported in 1080p, 1080i, or 720p. The switcher must be operating in one of these formats, or UHDTV1, for ViewControl to operate.
- When the switcher is operating in UHDTV1, the ViewControl output is 1080p.
- Only inputs 3 or 8 can be used for the ViewControl overlay in UHDTV1.
- Set the output resolution of the Dashboard computer to either 1920×1080 or 1280×720.
- Use an HDMI to SDI converter to take the output of the Dashboard computer and put it into a resolution that the switcher can use. Ensure that the resolution is not changed.
- Apply a FSFC to the input that is coming from the Dashboard computer.
- Set up a MultiViewer to use a ViewControl layout.
- Use an SDI to HDMI converter to take the output of the switcher and put it into a resolution that the touchscreen can use. Ensure that the resolution is not changed.
- Connect the USB cable for the touchscreen to the Dashboard computer.

### To Set Up the MultiViewer for ViewControl over HDMI™

ViewControl integrates the MultiViewer output of the switcher with a graphical overlay from Dashboard to provide live video in the ViewControl windows. The MultiViewer must be configured to properly align the video for the buttons on ViewControl.

**Note:** The switcher must be operating in a 1080p, 1080i, or 720p video format for ViewControl to operate.

**Note:** Only the Video Processor MultiViewer can be used for ViewControl.

1. Click **Navigation Menu > Configuration > MultiViewers** and click **MV VP 1**.



2. Click the **Layout** button and select a ViewControl layout.

- **VCtrlT** — (**ViewControl Top**) places the boxes at the top of the screen.
- **VCtrlB** — (**ViewControl Bottom**) places the boxes at the bottom of the screen.

**Tip:** If you want to create a custom ViewControl layout, you can use one of the other MultiViewer layouts to create the look you want, and use PanelBuilder in Dashboard to assign functionality to the layout. Sources can be hidden from a layout by assigning black to the box. For more information on PanelBuilder, refer to the Dashboard documentation.

3. Click the **Overlay** button and click **On** to turn the overlay on.
4. Click the **Source** button for the overlay input from Dashboard. This is keyed over the MultiViewer layout.

**Note:** In UHDTV1, only inputs 3 or 8 are available to be used for the overlay.

5. Use the **Clip** slider to adjust the clipping of the overlay source.

At **0%** the overlay source is completely opaque, and at **100%** it is completely transparent.

6. Click on one of the **Boxes** buttons and set up how that box appears on the MultiViewer.
7. Click on the source you want to select for the box.

**Note:** The large box on the left should always be assigned to **PV** and the large box on the right assigned to **PGM**.

### Connecting ViewControl over NDI®

ViewControl combines an overlay image from Dashboard with a custom MultiViewer output from the switcher to generate the interface. This requires a single SDI to NDI® converter, as well as a touchscreen display.



**Important:** ViewControl over NDI® is not supported on computers running the macOS® operating system at this time.

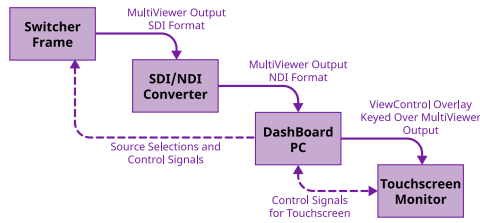

The following connections are required for ViewControl:

- ViewControl is only supported in 1080p, 1080i, or 720p. The switcher must be operating in one of these formats, or UHD TV1, for ViewControl to operate.
- When the switcher is operating in UHD TV1, the ViewControl output is 1080p.
- Set the output resolution of the DashBoard computer to either 1920×1080 or 1280×720.
- Use an SDI to NDI<sup>®</sup> converter to take the output of the switcher and make it available to DashBoard.
- Set up a MultiViewer to use one of the ViewControl layouts that support NDI<sup>®</sup>.
- Connect the USB cable for the touchscreen to the DashBoard computer.

### Keep the following in mind:

Keep the following in mind when working with NDI<sup>®</sup>:

- The NDI<sup>®</sup> converter and DashBoard computer running ViewControl should be on the same subnet.
- The NDI<sup>®</sup> Access Manager from the NDI<sup>®</sup> Tools (<https://www.ndi.tv/tools/>) may be required for the NDI<sup>®</sup> stream to appear in ViewControl.
- If required, the NDI<sup>®</sup> Access Manager must be installed on the DashBoard computer running ViewControl.
- When using the NDI<sup>®</sup> Access Manager you will need to add the IP address of the NDI<sup>®</sup> converter to the **Remote Sources** tab.
- You may have to restart the DashBoard computer running the NDI<sup>®</sup> Access Manager before the NDI<sup>®</sup> stream becomes visible to ViewControl.
- You must set the NDI<sup>®</sup> connection in ViewControl every time DashBoard is launched.

### To Set Up the MultiViewer for ViewControl over NDI<sup>®</sup>

ViewControl integrates the MultiViewer output of the switcher with a graphical overlay from DashBoard to provide live video in the ViewControl windows. The MultiViewer must be configured to properly align the video for the buttons on ViewControl.

**Note:** The switcher must be operating in a 1080p, 1080i, or 720p video format for ViewControl to operate.

**Note:** Only the Video Processor MultiViewer can be used for ViewControl.

1. Click **Navigation Menu > Configuration > MultiViewers** and click **MV VP 1**.



2. Click the **Layout** button and select a ViewControl layout for NDI<sup>®</sup>.
  - **VCNDIT** — (**ViewControl Top**) places the boxes at the top of the screen.
  - **VCNDIB** — (**ViewControl Bottom**) places the boxes at the bottom of the screen.

**Tip:** You must select one of the NDI<sup>®</sup> layouts to be able to select the NDI<sup>®</sup> input stream.

3. Click **Shift Panel** and select the panel that you will be operating ViewControl from. When the **Shift** button is pressed on the assigned control panel the MultiViewer shows the shifted sources.

**Note:** The shift function must be active for the PRV and PGM boxes on the MultiViewer to switch to the active ME.

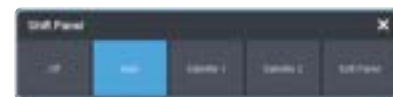

**Tip:** When the MultiViewer Shift is active, the box buttons on the layout show the shifted source in brackets.

4. Click on one of the **Boxes** buttons and set up how that box appears on the MultiViewer.
5. Click on the source you want to select for the box.

**Note:** The large box on the left should always be assigned to **PV** and the large box on the right assigned to **PGM**.

---

### To Set Up ViewControl for NDI®

Select the NDI® stream that is coming from the switcher that has the MultiViewer video stream.

**Note:** Refer to the documentation that came with your SDI to NDI® Converter for information on setting it up.

1. Click the  button in the bottom right corner of the window.



2. Click **Update NDI Source List** and click the NDI® source that has the MultiViewer output from the switcher.

**Note:** The MultiViewer must be set to one of the NDI® layouts for the NDI® source selection to be available.

3. Click an **NDI Quality** button to select if you want to use the normal (**High**) or low bandwidth (**Low**) stream.

**Tip:** Use the **Low** setting for best performance on a Macintosh® computer.

4. Click **Save**.

# MultiPanel

Each frame supports up to 3 independent control connections (Main, Satellite 1, and Satellite 2) as well as Satellite 3/SoftPanel. Each connection, with the exception of SoftPanel, can be from a control panel, DashBoard, or a combination of the two. All devices on the same control connection mirror each other.

The independent control connections are selected by the port you connect to on the frame. Multiple panels and DashBoard connections can connect on the same port, but they will all share the same permissions and mirror each other for control.

- **Main Panel** — 5253 (5258 NAT)
- **Satellite 1** — 5255 (5259 NAT)
- **Satellite 2** — 5256 (5260 NAT)
- **Satellite 3/SoftPanel** — 5257 (5261 NAT)

## Keep the following in mind:

Keep the following in mind when working with MultiPanel:

- SoftPanel shares the permissions of the Main Panel.
- The assignment of the panel ID is done from the control panel.
- Control panel specific personality settings are stored on the frame for the panel ID and are not tied to the control panel.
- DashBoard automatically follows the main panel but will ignore permissions set for the main panel.
- If you change switcher modes, the MultiPanel permissions may have to be set again.
- An undo of a memory recall ignores panel permissions and will undo the last memory recalled from any panel.
- Bus maps are specific to each control panel. Creating or updating a bus map for one control panel does not change the bus map on another control panel.
- Custom controls ignore control panel permissions and will run events on an ME, MiniME™, or Canvas that the control panel does not have permission for.

## To Set Up MultiPanel Permissions

*Tip: MultiPanel permissions can also be set from the Ultritouch.*

1. Click **Navigation Menu > Configuration > System > MultiPanel**.



2. Click a **Main**, **Sat 1**, or **Sat 2** button to select whether that control connection has access to that resource.

*Note: SoftPanel and Main share the same permissions.*

*Note: A control panel must have permission to at least one ME, MiniME™, or Canvas.*

# MIDI Controller

The MIDI controller is used to control the RAVE audio mixer. The controller connects to RAVE through DashBoard.

For these procedures you will need the following files. They are available with these instructions in your download or on your product resources USB.

- X-TOUCH-map###.controller
- Mapping Wizard.grid
- X-TOUCH-LayerA###.bin
- X-TOUCH-LayerB###.bin



**Important:** The revision numbers (###) of the .controller and .bin files must match.

MIDI and MMA are trademarks of the MIDI Manufacturers Association.

## Compatibility

The MIDI controller and bin files are only compatible with specific versions of Ultra software.

Ultra Software	MIDI Files
4.0 or higher	<ul style="list-style-type: none"><li>• X-TOUCH-map005.controller</li><li>• X-TOUCH-LayerA005.bin</li><li>• X-TOUCH-LayerB005.bin</li></ul>

## To Connect the X-TOUCH COMPACT to DashBoard

DashBoard allows you to configure the MIDI controller connected to RAVE audio mixer.



**Important:** Refer to the documentation that came with your X-TOUCH COMPACT for proper handling and setup instructions.

1. Plug the MIDI controller into one of the USB ports on your DashBoard computer. DashBoard must also be connected to the switcher.
2. Launch DashBoard.
3. Click **File > New > Other**.
4. Click **Input Devices > New MIDI Controller**.
5. Click **Next**
6. Enter the settings for the MIDI Controller:
  - **Display Name** — enter a name for the controller

- **Slot** — select **1**
- **Controller** — select **X-TOUCH COMPACT**

7. Click **Finish**.  
The MIDI controller appears in the **Tree View**.

## To Configure the X-TOUCH COMPACT Interface

A custom DashBoard panel is used to automatically do all the mapping for the X-TOUCH COMPACT.

You will need the Mapping Wizard.grid file that came with your software.

1. Launch DashBoard.
2. Click **File > Open File**, navigate to the Mapping Wizard.grid file and click **Open**.
3. In the **MIDI** field, select **X-TOUCH COMPACT**.
4. In the **Graphite** field, select **Audio Mixer**.
5. Click **DO EVERYTHING FOR ME**.

## To Configure the Button Layers on the X-TOUCH COMPACT

The Layer A and Layer B files assign the controls on the X-TOUCH COMPACT to MIDI Commands

Default layer files are provided on the product resources disk, or you can customize your own.

**Note:** The layer files must match the map file that you load in DashBoard.

1. Connect the X-TOUCH COMPACT to the server.
2. Launch the **X-TOUCH Editor** application that came with your controller.
3. Click the **GLOBAL** tab.
4. Click **LOAD** in the **PRESETS ON COMPUTER** area and click **Yes**.
5. Select the X-TOUCH-LayerA#####.bin file and click **Open**.
6. Wait for the file to be loaded and click **Close** on the success dialog box.
7. Click **Dump A** in the **TO HARDWARE** area.
8. Click **Yes** to start the upload and **Close** on the success dialog box.
9. Repeat these steps to load the X-TOUCH-LayerB#####.bin file and click **Dump B**.



## To Map Buttons to Functions

The map file associates RAVE audio mixer functions to buttons on the X-TOUCH COMPACT.

A default map file is provided on the product resources disk, or you can customize your own.

1. Double-click the **MIDI Controller** node in the DashBoard Tree View.
2. Click **Load > Browse** and select the X-TOUCH-map####.controller file.
3. Click **Open > Restore**.

## Default X-TOUCH COMPACT Mapping

The default mapping comes from the map and layer files that are included on the Product Resources disk.

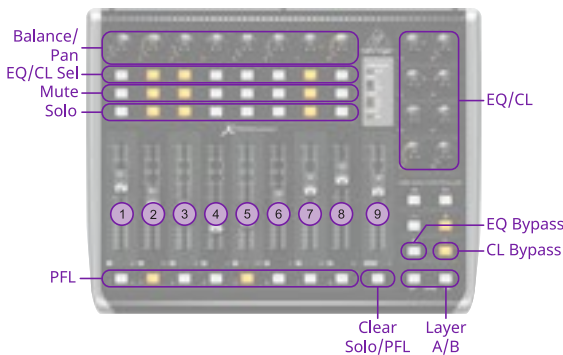

**Note:** The **Clear** button clears the Solo selections on Layer A and the PFL selections on Layer B.

### Fader Mapping

The faders are mapped differently on the A and B layer.

Fader	Layer A	Layer B
1	Audio 1	Audio 9
2	Audio 2	Audio 10
3	Audio 3	Audio 11
4	Audio 4	Audio 12
5	Audio 5	Audio 13
6	Audio 6	Audio 14
7	Audio 7	Audio 15
8	Audio 8	Audio 16
9	MAIN	MONITOR

**Note:** The default assignment is based on the default fader configuration. If you change what is assigned to any of the assignable faders (Audio X) used on the default map, the audio sources those faders control also changes. For example, if you assign **Audio 5** to SDI 5, the stripe on the midi panel will control SDI 5 audio.

### Equalizer Control

The **EQ/CL Sel** buttons are used to select which source the EQ is being adjusted for, and the **Layer A/B** buttons are used select what range is assigned to the knobs. The knobs are then used to adjust the EQ values.

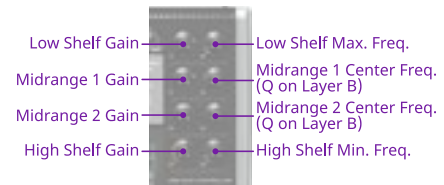

### Compressor / Limiter Control

The **EQ/CL Sel** buttons are used to select which source the Compressor is being adjusted for, and the **Layer B** knobs are used to adjust the compressor values.



## Custom Mapping

You can change the current mapping of functions to the buttons, knobs, and sliders on the X-TOUCH COMPACT. The DashBoard controller lists all the inputs on the MIDI controller and allows you to assign a DashBoard OID to them.

Refer to [MIDI Device OID List](#) on page 222 for a list of available OIDs.



**Important:** Although you can assign different functions to the knobs, sliders, and buttons on the panel, some functions may require changes to the layers in the **X-TOUCH Editor** application. Refer to the documentation that came with your X-TOUCH COMPACT for more information.



- 
- [Mapping](#) on page 145 for a diagram to locate the buttons.
- b) In the **Mapped OID** field, enter the OID for the function you want to assign to the button. Refer to [MIDI Device OID List](#) on page 222 for a list of OIDs.
  - c) Click the **Action** list and select the type of action for the button.
    - **OFF** — (not supported at this time)
    - **Stateless** — basic button functionality with no special state.
    - **GPI** — (not supported at this time)
    - **Set Value** — (not supported at this time)
    - **Toggle** — (not supported at this time)
    - **Increment** — (not supported at this time)
  - d) Change the default parameters for your button as required.
    - **Name** — enter a new custom name for the control.
    - **Value (Off)** — 0 (other values not supported at this time)
    - **Value (On)** — 1 (other values not supported at this time)
    - **Min** — 0 (other values not supported at this time)
    - **Max** — 1 (other values not supported at this time)
    - **Hold** — (not supported at this time)
4. Click the **Force Panel Refresh** list and select the how often DashBoard syncs with the panel.
  5. Click **Save**.
  6. Click **Save** again and select a file name and location for your custom controller file.
  7. Click **Save**.
  8. Click **Done**.

# Diagnostics

Switcher status menus and error conditions, installed options, calibration, diagnostics, and logs.

## Switcher Status

The status menu shows information for various components of the frame.



- **Software Version** — the current version of the software running on the switcher.
- **Video Processor Serial Number** — the serial number of the video processor board.

*Note: If you are asked for the Serial Number of your frame, it can be found on a label affixed to the chassis. The Video Processor Serial Number is used to identify the video processor board that is installed in the frame.*

- **Engine Type** — the model of switcher.
- **Switcher Mode** — the current mode the switcher is operating in.
- **Video Mode** — the video format that the switcher is operating in.
- **Video Reference Source** — the source of video reference to the switcher (internal/external).
- **External Reference** — the video format of the external reference, if connected.
- **Reference** — status of whether the switcher has locked to the reference format.
- **Field Dominance** — the switching field.
- **Ancillary Mode** — how ancillary data is handled (strip or pass).
- **Timecode** — the current timecode being received by the switcher.
- **Panel Slot** — the control connection the DashBoard interface is using (Main/Satellite).
- **Main Panel DashBoard Port** — the local and NAT network port that the switcher is listening on for the main panel.
- **Satellite 1 DashBoard Port** — the local and NAT network port that the switcher is listening on for the satellite 1 panel.
- **Satellite 2 DashBoard Port** — the local and NAT network port that the switcher is listening on for the satellite 2 panel.

- **SoftPanel DashBoard Port** — the local and NAT network port that the switcher is listening on for the SoftPanel.
- **RossTalk Server Port** — the network port that the switcher is listening on for RossTalk commands.
- **TSL UMD 3.1 Server Port** — the network port that the switcher is listening on for TSL UMD commands.
- **TSL UMD 5 Server Port** — the network port that the switcher is listening on for TSL UMD commands.
- **Temperature** — status of the ambient temperature in the frame.
- **CPU Temperature (C)** — the temperature of the frame CPU in degrees Celsius.
- **VP FPGA Temperature (C)** — the temperature of the frame video processor FPGA in degrees Celsius.
- **IO FPGA Temperature (C)** — the temperature of the frame I/O processor FPGA in degrees Celsius.
- **Fan 1 Speed** — speed and status of fan 1 in the frame.
- **Fan 2 Speed** — speed and status of fan 2 in the frame.
- **Fan 3 Speed** — speed and status of fan 3 in the frame.
- **Power Supply 1** — is power supply 1 connected to a power source.
- **Power Supply 2** — is power supply 2 connected to a power source.
- **Allocated DVEs** — where DVE channels are allocated in the switcher.
- **DashBoard Connections** — the IP addresses of all the DashBoard connections to the switcher, including panels. The port number after the IP address indicates the role each DashBoard connection is filling. Refer to [MultiPanel](#) on page 143 for more information.

*Note: The frame supports a maximum of 20 DashBoard connections at any one time. If there are already the maximum number of connections to a frame you will not be able to connect to it.*

## Switcher Information Text File

The switcher information file contains the software version and IP address of the switcher. When you plug a USB drive into the USB port on the switcher, a `swInfo.txt` file is created at the root directory of the USB. This text file contains the current software version number

and IP address of the switcher, as well as other helpful information:

- **SW Version** — the current software version installed on the switcher.
- **IP Address** — the local IP address of the switcher. This will not include any external NAT IP addresses.
- **MicroSD Card Installed** — shows whether the microSD™ card is installed in the switcher.

The last line in the file is the date and time that the file was last created on the USB.

## Switcher Logs

Switcher logs can be used to identify and diagnose problems with the switcher. Use this information when contacting Ross Video Technical Support.

A copy of the working set from the switcher is also included with the logs to assist in diagnosing problems.

### To Copy Logs To a USB

Switcher logs can be stored onto a USB to be sent to technical support to diagnose problems with your switcher.

*Tip: Logs can also be exported to your DashBoard computer instead of saving them to the USB. Click **Export As...** in the **Export Logs From Frame** area and select the location on your computer to save the logs file.*

*Note: Logs must be copied before a reboot or power-cycle of the switcher, or the information in them will be lost.*

1. Insert USB drive into the USB port on the frame. Wait 5 seconds after inserting the USB drive before using it.
2. Click **Navigation Menu > Configuration > Diagnostics**.



3. Click the **Copy Logs To USB** button to copy the switcher logs to the USB drive.

*Tip: You can have logs stored directly to the USB drive. Click a **Logs Direct to USB** button to select **Yes**.*

The logs have been copied into the \switcher directory on the USB drive.

## Diagnostic Tests

Diagnostics consist of a number of tests that are used to confirm the functionality of your equipment.

### To Run the Tally Test

The Tally Test turns all tallies off, and then turns each tally on consecutively. There is a three (3) second delay between each tally being toggled on. Once the last tally has been turned on, all the tallies blink on and off three times.



*Important: A control panel is required to perform this procedure. If you do not have access to a physical control panel, the SoftPanel can be used. The position of items on the menus on the SoftPanel may not match those of a physical panel.*

1. Press **MENU > System > NEXT > NEXT > Diagnostic Tests (Diag Tests on Carbonite Black) > NEXT > NEXT > Tally Test**. All tallies are turned off, and then each tally is turned on consecutively. There is a three (3) second delay between each tally being toggled on. Once the last tally has been turned on, all the tallies blink on and off three times.
2. Press **MENU** to end the test.

### To Run the GPI Input Test



*Important: A control panel is required to perform this procedure. If you do not have access to a physical control panel, the SoftPanel can be used. The position of items on the menus on the SoftPanel may not match those of a physical panel.*

1. Press **MENU > System > NEXT > NEXT > Diagnostic Tests (Diag Tests on Carbonite Black) > NEXT > NEXT > GPI Test**. The second line of the menu show the state of all GPI input pins as High or Low.
2. Press **MENU** to end the test.

### To Run the GPI Output Test



*Important: A control panel is required to perform this procedure. If you do not have access to a physical control panel, the SoftPanel can be used. The position of items on the menus on the SoftPanel may not match those of a physical panel.*

1. Press **MENU > System > NEXT > NEXT > Diagnostic Tests (Diag Tests on Carbonite Black) > NEXT > NEXT > GPO Test**. All GPI outputs are turned off, and then each one is turned on consecutively. There is a

three (3) second delay between each GPI output being triggered. Once the last tally has been triggered, all the GPI outputs blink on and off three times.

2. Press **MENU** to end the test.

### To Run the Control Panel Test

Test the functionality of any of the buttons, knobs or fader and positioner on the control panel.



**Important:** This test disrupts the functionality of the control panel. If you are running this test from a remote computer, ensure that the control panel is available before performing the test.

1. Click **Navigation Menu > Configuration > Diagnostics.**



2. Click **Start Control Test.**

The button shows Running and the 3-knob menu of the control panel shows the current button, knob, positioner, or fader being used.

3. Test the button, knob, positioner, and fader you want to check.

**Note:** On the TouchDrive control panel the displays show a touch pattern. Tap on the happy face to test the touch sensitivity and calibration. If the tap registers on the happy face, the happy face disappears. If the tap does not register on the happy face, a green X is shown where the tap was registered.

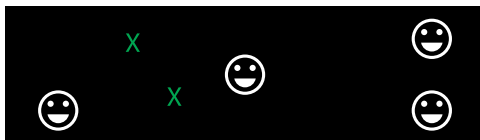

4. Click **Stop** or press **MENU** and **NEXT** on the control panel to end the test.

### To Run the LED Test

Test the color range of all the LEDs on the control panel.



**Important:** This test disrupts the functionality of the control panel. If you are running this test from a remote computer, ensure that the control panel is available before performing the test.

1. Click **Navigation Menu > Configuration > Diagnostics.**



2. Click **Start P-LEDs Test.**

The button shows Running and all the buttons and indicators on the control panel cycle through different colors.

3. Click **Stop** or press **MENU** on the control panel to end the test.

### To Run the Display Test

Test the displays on the control panel.



**Important:** This test disrupts the functionality of the control panel. If you are running this test from a remote computer, ensure that the control panel is available before performing the test.

1. Click **Navigation Menu > Configuration > Diagnostics.**



2. Click **Start Display Test.**

The button shows Running and on the TouchDrive the displays and the mnemonics cycle colors.

On the Carbonite Black a series of letters, numbers, and symbols scroll across the displays and the mnemonics cycle colors.

3. Click **Stop** or press **MENU** on the control panel to end the test.

## Error Messages

The switcher will show an error message on the control panel display when a problem is detected.

The following error messages may appear when starting your switcher.

**Table 7: Switcher Error Messages**

Error	Description	Solution
<b>DDR 0 Not Found; DDR 1 Not Found; or DDR 0 &amp; 1 Not Found</b>	There is a problem with the switcher DDR memory. The switcher may be used but many features will be limited or disabled.	Re-start your switcher. If the problem persists, contact Ross Video Technical Support for assistance.
<b>Panel/Frame Mismatch</b>	Your switcher control panel is connected to the wrong frame type.	Connect your switcher control panel to the proper frame and re-start the switcher.
<b>Upgrade PMC?</b>	Your switcher requires a Panel Module Controller (PMC) upgrade as part of a software upgrade. The switcher may be used without the PMC upgrade but may respond in an unpredictable manner.	Allow the PMC upgrade to proceed. Contact Ross Video Technical Support for assistance if you are unsure about upgrading your switcher.
<b>Unknown panel type Please upgrade</b>	The frame does not recognise the control panel. This could be caused by an unsupported panel being connected to the frame, or a problem with the panel module controlled or the configuration files.	Ensure that you have the correct control panel connected to the frame. If the problem persists, download the latest upgrade file from and force an upgrade of the switcher. Contact Ross Video Technical Support for assistance if you are unsure about upgrading your switcher.

## Switcher Reset

If required, the switcher can be reset to return it to a user-defined default setting (RState), or the factory default state. A reset can be performed for the entire switcher, or individual components, such as keys.

### Custom Reset Settings (RState)

You can customize many of the default switcher parameters and save them as a user-defined reset settings. These custom reset settings can then be recalled when you want to return the switcher to a previous state.

#### To Save a Custom Reset Setting

The Custom Reset Setting, or RState, saves how you want the switcher to be configured when it

powers up, or when you recall the RState manually.

1. Click **Navigation Menu > Live Assist > Memory > RState**.



2. Click **AuxX, MediaX, MiniMEX, CanvasX, and UltraScene** to select the buses or channels that are reset with a switcher reset.

**Note:** If **Disable Audio Memories** is set to **On** (Click **Navigation Menu > Configuration > System > Global**) the audio attributes are disabled.

**Tip:** Click the **All** button to select or de-select all the items in that category.

3. Click **Save RState** and **Yes**.

#### To Load a Custom Reset Setting (RState)

The Custom Reset Setting, or RState, is recalled every time the switcher is powered on, or it can be recalled manually.

1. Click **Navigation Menu > Live Assist > Memory > RState**.
2. Click **Load RState** and **Yes**.

**Tip:** Click **Default RState** to load the default RState settings.

## Factory Default Settings

You can restore all or part of the switcher to the factory default state. A factory default returns all installation and personality settings are reset.

### To Factory Reset the Switcher

Return the switcher to the factory default settings.

1. Click **Navigation Menu > Configuration > System > Reset**.



2. Click a reset or clear button to return that feature to the factory default state.
  - **Clear Memories** — clear all memory registers on the switcher.

- **Clear CCs** — clear all custom controls on the switcher.
- **Clear Sequences** — clear all Sequencers on the switcher.
- **Clear UltraScenes** — clear all UltraScenes on the switcher.
- **Default Bus Map** — return the bus map to the default mapping.
- **Factory Reset** — return the installation and personality registers to the default settings.

## Frame DIP Switches

There are a number of DIP switches inside the frame that are used to diagnose the operation of the switcher.

**Table 8: Ultra Frame DIP Switches**

DIP	Description
1	This DIP switch is used to set the IP address of ethernet port on the frame to the default value (192.168.0.123). It must be in the up (off) position to set another IP address for the frame.
2	This DIP switch is unused and should be left in the default up (off) position.
3	This DIP switch is unused and should be left in the default up (off) position.
4	This DIP switch prevents software upgrades. It must be in the up (off) position to upgrade the switcher.
5	This DIP switch is unused and should be left in the default up (off) position.
6	This DIP switch is unused and should be left in the default up (off) position.
7	This DIP switch is unused and should be left in the default up (off) position.
8	This DIP switch is unused and should be left in the default up (off) position.



---

## Software Upgrade

The switcher software is upgraded from DashBoard either by dragging and dropping the software onto the Upgrade page, or by saving the upgrade file to the USB drive inserted in the frame.

Depending on the version of software you are upgrading from, your menus may be arranged or appear differently.



**Important:** Refer to the Upgrade Notes for the version of software you are upgrade to for hardware compatibility and operational issues or changes.

5. Power cycle the frame by switching the power button **Off** and then **On** again.

The switcher will come up with the new software version.

## To Upgrade the Switcher Software

Use DashBoard to upload the upgrade file to the switcher.

**Note:** Save your switcher setup information to a set on a separate USB drive before upgrading. This switcher set can be used as a backup in case there is a critical error during the upgrade.

**Tip:** Switcher sets are not backwards compatible. Keep an archive copy of your sets in case you want to downgrade to the previous software version.



**Important:** Do NOT turn the switcher power off during the upgrade. Doing so may corrupt the switcher software or damage the switcher components.

1. Click **Navigation Menu > Configuration > System > Upgrade**.



2. Locate the upgrade file for the switcher and drag and drop it into the **Drag and Drop Upgrade** area on DashBoard.

**Tip:** You can also upgrade from the USB. All upgrade files located on the USB are shown in the **USB Upgrade** area. Click the file you want to use and click **Upgrade**.

**Tip:** You can also upgrade by clicking **Browse**, locating the upgrade file, and then clicking **Upload File**.

The file is uploaded to the switcher.

3. Click **OK** to confirm the upgrade.
4. Wait for the DashBoard pages to come back up. This may take a few minutes.

# Specifications

Switcher resources, video specifications, power rating, and port pinouts.

## Resources

The number of resources specific to your switcher depends on the options installed.

	SD 4 Key	HD 4 Key	HD SRC 4 Key	HD ROT 4 Key	HD 6 Key	HD SRC 6 Key	HD ROT 6 Key	UHD	
<b>Audio</b>									
Audio Mixer Faders	48								
Mix Layers	13								
Max 1RU Audio Breakout Module	3							0	
Sample Rate Converters	No	Yes	No	No	Yes	No	Yes		
<b>Video</b>									
MEs (Max) <sup>2</sup>	3			2					
MiniME™ Engines	4							2	
Keyers per ME (+Trans)	4			6					4
Canvas Generators	2 <sup>1</sup>							1 <sup>1</sup>	
Video Processor MultiViewer (Max) <sup>2</sup>	2							1	
MultiViewer Boxes	16								
MultiViewer Layouts	51								
I/O MultiViewer (Max) <sup>2</sup>	2							1	
I/O Processor (Max) <sup>2</sup>	34		--	34		--	-- <sup>3</sup>		
Input FSFCs/Output FCs (Min)	-- <sup>3</sup>		-- <sup>6</sup>	-- <sup>3</sup>		-- <sup>6</sup>	2 <sup>4</sup>		
Input FSFCs (Max) <sup>2</sup>	-- <sup>3</sup>		12		-- <sup>3</sup>		12 7		
Output FCs (Max) <sup>2</sup>	-- <sup>3</sup>	2 <sup>5</sup>	-- <sup>6</sup>	-- <sup>3</sup>		-- <sup>6</sup>	4		

	SD 4 Key	HD 4 Key	HD SRC 4 Key	HD ROT 4 Key	HD 6 Key	HD SRC 6 Key	HD ROT 6 Key	UHD
Frame Delay (Max Frames)	--	13						7
Proc Amp/Color Correctors (Max) <sup>2</sup>	-- <sup>3</sup>							7
2D DVE Channels Switcher Wide	8							4
Output Rotators	--	3		--	3		--	
Aux Buses	28							
Chroma Keys (floating)	4							2
Custom Controls	256 (8 Banks × 32 CCs)							
Max Events per CC	998							
GPI I/Os	24							
Media-Store Channels (Video + Alpha)	4							2
Media-Store CACHE	8 GB							
Memories per ME	100							
Pattern Generators per ME	2							1
Matte Generators per ME	2							1
Matte Generators (1 per ME + Global)	7							4
Tallies	24							
SDI Video Inputs	24							18
SDI Video Outputs	14							10
Frame IP (default)	192.168.0.123							
Panel/CarboNET IP (default)	192.168.0.129							

## Notes:

<sup>1</sup> Each Canvas consumes MiniME™ engines to generate the output. The number of Canvas outputs that are available depends on the number of MiniME™ engines that are available.

<sup>2</sup> Software options are required to be installed to activate the maximum number of resources.

<sup>3</sup> In SD or HD, the total number of color correctors, input FSFCs, and output FCs is shared. In UHDTV1 there are dedicated color corrector, input FSFC, and output FC resources.

<sup>4</sup> There are 2 FSFCs that are shared between inputs and outputs.

<sup>5</sup> In the HD SRC 4 Key mode, only outputs 5 and 6 support FC.

<sup>6</sup> In the ROT (Rotation) modes, there are only 12 inputs FSFCs.

**Table 9: Audio Mixer Available Audio Channels**

	0 ABM	1 ABM	2 ABM	3 ABM
Analog	0	4 stereo pairs	8 stereo pairs	12 stereo pairs
AES	0	1 stereo pair	2 stereo pairs	3 stereo pairs
SDI (1-24) <sup>1</sup>	192 stereo pairs	184 stereo pairs	176 stereo pairs	172 stereo pairs
Media-Store (1-2)	2 stereo pairs	2 stereo pairs	2 stereo pairs	2 stereo pairs
<b>Total Channels</b>	<b>194 stereo pairs</b>	<b>191 stereo pairs</b>	<b>188 stereo pairs</b>	<b>189 stereo pairs</b>

## Notes

<sup>1</sup> When the 1RU Audio Breakout Module is connected to the switcher, the HD-BNCs used for the SDI-Audio Loop are not available for embedded audio. This uses one SDI input and one SDI output.

## Hardware Weights

Hardware	Weight
Ultra	13 lbs (5.90 kg)

## Environmental Characteristics

All Switchers	
Ambient Temperature Range	Operating: 0 - 40°C (32 - 104°F) Storage: -20 - 85°C (-4 - 185°F)
Frame Cooling	Active, Front-to-Back airflow

## Video Input Specifications

Input Specification	Value
UHDTV1 Video Formats	UHDTV1 23.98/24/25/29.97/30/50/59.94/60 (UHD-2SI)
HD Video Formats	1080p 23.98/24/25/29.97/30/50/59.94/60 1080pSF 23.98/24/25/29.97/30 1080i 50/59.94 720p 50/59.94
SD Video Formats	480i, 576i
Dynamic Range Support (HD and UHDTV1 only)	Standard Dynamic Range (SDR) Hybrid Log Gamma (HLG) Perceptual Quantizer (PQ) Sony® S-Log3.
Color Gamut Support (HD and UHDTV1 only)	BT.709 BT.2020
Equalization (using Belden 1694 cable)	>40m @ 12Gb/s (5°-40°C)
	>50m @ 3Gb/s (5°-40°C)
	>100m @ 1.5 Gb/s (5°-40°C)
	>300m @ 270 Mb/s (5°-40°C)
Impedance	75 ohm, terminating
Video Inputs, SDI	SMPTE 259M/292M/424M/ST-2082 (non-looping)
Reference Inputs (terminating)	Standard Definition — analog black
	High Definition — tri-level sync

## Video Output Specifications

Output Specification	Value
UHDTV1 Video Formats	UHDTV1 23.98/24/25/29.97/30/50/59.94/60 (UHD-2SI)
HD Video Formats	1080p 23.98/24/25/29.97/30/50/59.94/60 1080pSF 23.98/24/25/29.97/30 1080i 50/59.94 720p 50/59.94
SD Video Formats	480i, 576i

Output Specification	Value
Return Loss	<-7.8dB @ 12GHz
	<-10dB @ 3GHz
	<-15dB @ 1.5GHz
Rise and Fall Time	26ps ±10% (UHD)
	240ps ±10% (HD)
	800ps ±10% (SD)
Signal Level	800mV ±10%
DC Offset	0 Volts
Overshoot	<10%
Video Outputs, SDI HD Mode	10-bit SMPTE-292M/424M serial digital
Video Outputs, SDI UHDTV1 Mode	SMPTE ST 2082-1:2015 (Amendment 1:2016)

## Audio Specifications

Specification	Value
Audio Depth	24-bit AES3 in HD (20-bit in SD)
Channels	1 Stereo Pair (2 channels)
Output	AES
File Format	Multi-channel Waveform Audio File (.wav)
Impedance	110 Ohms, differential
Minimum/Maximum output voltage swing	1.5/6V peak-to-peak
Rise and Fall Times	20ns, typical
Sample Rate	48kHz
Synchronization	Locked to Video

## ABM Analog Audio Input Specifications

Analog audio inputs on the 1RU Audio Breakout Module.

Specification	Value
Input Impedance	XLR: 2K ohm
	¼" Jack: 10K ohm
Maximum Level	+24dBu
Frequency Response	±0.3dBu (22Hz to 20kHz @ Fs = 48kHz)

Specification	Value
Signal to Noise Ratio	-95dB
• "A" Weighting	-98dB
• CCITT Weighting	-107dB
THD	>93dB or <0.002%
Amplitude Linearity	<0.8dB @ -100dBFS
Crosstalk	-94dB

## ABM Analog Audio Output Specifications

Analog audio outputs on the 1RU Audio Breakout Module.

Specification	Value
Maximum Level	+24dBu
Frequency Response	±0.4dB (22Hz to 20kHz @ Fs = 48kHz)
Signal to Noise Ratio	-103dB
THD	>93dB
Amplitude Linearity	<0.3dB @ -100dBFS
Crosstalk	-106dB (20Hz to 20kHz)

## Jitter

Specification	Value
UHD - Tri-Level Sync	Alignment (> 100KHz) < 0.21UI
	Timing (<10Hz) < 1.84UI
UHD - Composite Reference	Performance not guaranteed with composite reference
HD - Tri-Level Sync	Alignment (> 100KHz) < 0.2UI
	Timing (<10Hz) < 1.0UI
HD - Composite Reference	Performance not guaranteed with composite reference
SD - Tri-Level Sync	Alignment (> 1KHz) < 0.2UI
	Timing (<10Hz) < 0.2UI
SD - Composite Reference	Alignment (> 1KHz) < 0.2UI
	Timing (<10Hz) < 0.5UI

## System Timing

- All video inputs zero time relative to reference input, auto timing will correct for inputs out of time by up to +/- 0.25 line.
- System delay is less than 1 line.

## Network Ports

The following network ports are used:

- DashBoard (OGP) — 5253
- DashBoard (JSON) — 5254
- DashBoard Main — 5253 (5258 NAT)
- DashBoard Sat 1 — 5255 (5259 NAT)
- DashBoard Sat 2 — 5256 (5260 NAT)
- DashBoard SoftPanel — 5257 (5261 NAT)
- FTP — 21
- FTP (Graphite CPC) — 8821
- SFTP — 2222
- Panel (port on panel) — 3333
- RossTalk — 7788
- SLP — 427
- SSH — 22
- TFTP — 69
- TSL 3.1 (TCP, Carbonite) — 5727
- TSL 3.1 (TCP, Ultrix™) — 5727
- TSL 3.1 (UDP, Ultrix™) — 4490
- TSL 5.0 (TCP, Carbonite) — 5728
- TSL 5.0 (TCP, Ultrix™) — 5729
- TSL 5.0 (UDP, Ultrix™) — 4492
- Web Server 1 — 80
- Ultritouch — 5254
- SideShot-NG — 5255

## Power Consumption — Frame

Ultra	
Consumption	114W 7.6A 15V
Input Voltage	100 - 120V~, 220 - 240V~, 47-63Hz

## Embedded Audio Assignment

The audio signals are passed back and forth between the 1RU Audio Breakout Module and 4RU Integrated Production System as embedded audio signals in the SDI loop between the components.

**Table 10: Embedded Audio Signals in SDI Stream From 1RU Audio Breakout Module**

Group	Channel	Input Signal to Mixer
1	1	Group 1 is passed through from SDI 1 IN unchanged.
	2	
	3	
	4	

Group	Channel	Input Signal to Mixer
2	1	Analog Input 1
	2	Analog Input 2
	3	Analog Input 3
	4	Analog Input 4
3	1	Analog Input 5
	2	Analog Input 6
	3	Analog Input 7
	4	Analog Input 8
4	1	AES Input — Left Channel
	2	AES Input — Right Channel
	3	unused
	4	unused

**Note:** All embedded audio streams going to the 1RU Audio Breakout Module pass through the hardware and are available on the SDI1 OUT.

**Table 11: Embedded Audio Signals in SDI Stream To 1RU Audio Breakout Module**

Group	Channel	Output Signal from Mixer
1	1	Main — Left Channel
	2	Main — Right Channel
	3	Aux 1 — Left Channel
	4	Aux 1 — Right Channel
2	1	Aux 2 — Left Channel
	2	Aux 2 — Right Channel
	3	Aux 3 — Left Channel
	4	Aux 3 — Right Channel
3	1	Aux 4 — Left Channel
	2	Aux 4 — Right Channel
	3	Aux 5 — Left Channel
	4	Aux 5 — Right Channel
4	1	Aux 6 — Left Channel
	2	Aux 6 — Right Channel
	3	Monitor — Left Channel
	4	Monitor — Right Channel

## Frame Ports

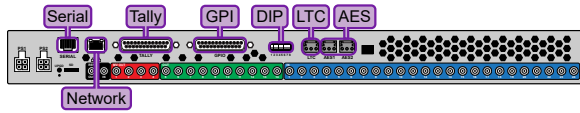

### Serial Port

The serial port supports the RS-422 transmission standard in the following format:

- 38.4k Baud
- 8 bits
- 1 stop bit
- Odd Parity

The serial ports use a female RJ-45 connector.

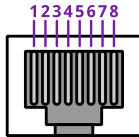
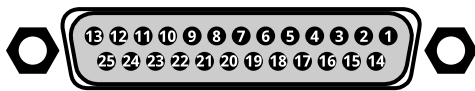

**Table 12: Serial Port Pinouts**

Pin	Signal
1	Tx+
2	Tx-
3	Rx+
4	n/c
5	n/c
6	Rx-
7	Ground
8	Ground

### GPI Port

The switcher supports 24 GPI I/Os on each female DB25 connector.



**Table 13: GPI I/O Pinouts**

Pin	Signal
1	GPI I/O 1
2	GPI I/O 2
3	GPI I/O 3
4	GPI I/O 4
5	GPI I/O 5
6	GPI I/O 6

Pin	Signal
7	GPI I/O 7
8	GPI I/O 8
9	GPI I/O 9
10	GPI I/O 10
11	GPI I/O 11
12	GPI I/O 12
13	GPI I/O 13
14	GPI I/O 14
15	GPI I/O 15
16	GPI I/O 16
17	GPI I/O 17
18	GPI I/O 18
19	GPI I/O 19
20	GPI I/O 20
21	GPI I/O 21
22	GPI I/O 22
23	GPI I/O 23
24	GPI I/O 24
25	Ground

### Tally Port

The switcher supports 24 fixed tallies on each female DB25 connector.

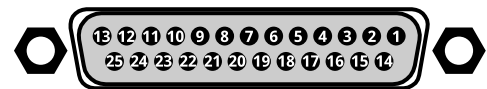

**Table 14: Tally Rating**

Specification	Value
Input Voltage	24VAC(rms)/40VDC
Maximum Current	120mA
Impedance	<15 ohm

**Table 15: Tally Pinouts**

Pin	Tally #
1	1
2	2
3	3
4	4
5	5

Pin	Tally #
6	6
7	7
8	8
9	9
10	10
11	11
12	12
13	13
14	14
15	15
16	16
17	17
18	18
19	19
20	20
21	21
22	22
23	23
24	24
25	Common

### AES Port

The AES ports on the back of the frame each support a single 24-bit (20-bit in SD) stereo pair.

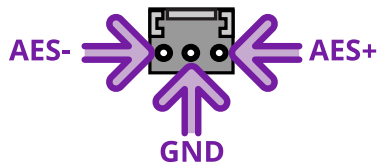

### LTC Port

The LTC port on the back of the frame supports a single LTC connection.

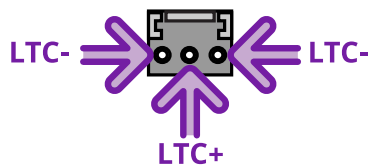

# Custom Control Events

The Custom Control editor in DashBoard allows you to add or edit events in custom controls.

## Operations Custom Controls

### Canvas (BKGD DVE)

Event	Location	Description
<b>BKGD DVE Size</b>	<b>Switcher &gt; Bkgd DVE &gt; Bkgd DVE Crop Param</b>	<p>Set the size of the background DVE for the selected Canvas.</p> <ol style="list-style-type: none"> <li>1. Click the <b>ME</b> button for the Canvas that you want to perform the event on.</li> <li>2. Click the <b>Parameter</b> button and select <b>Size</b></li> <li>3. Click the <b>Change Type</b> button and select whether you want to set <b>(Absolute)</b> or reset <b>(Reset)</b> the parameter. Some selections will not be available when you reset the parameter.</li> <li>4. In the <b>Value (%)</b> field, enter the size you want to apply to the Background DVE.</li> </ol>
<b>BKGD DVE X-Position</b>	<b>Switcher &gt; Bkgd DVE &gt; Bkgd DVE Crop Param</b>	<p>Set the X-Position of the background DVE for the selected Canvas.</p> <ol style="list-style-type: none"> <li>1. Click the <b>ME</b> button for the Canvas that you want to perform the event on.</li> <li>2. Click the <b>Parameter</b> button and select <b>X-Position</b></li> <li>3. Click the <b>Change Type</b> button and select whether you want to set <b>(Absolute)</b> or reset <b>(Reset)</b> the parameter. Some selections will not be available when you reset the parameter.</li> <li>4. In the <b>Value (%)</b> field, enter the position on the X-axis you want to apply to the Background DVE.</li> </ol>
<b>BKGD DVE Y-Position</b>	<b>Switcher &gt; Bkgd DVE &gt; Bkgd DVE Crop Param</b>	<p>Set the Y-Position of the background DVE for the selected Canvas.</p> <ol style="list-style-type: none"> <li>1. Click the <b>ME</b> button for the Canvas that you want to perform the event on.</li> <li>2. Click the <b>Parameter</b> button and select <b>Y-Position</b></li> <li>3. Click the <b>Change Type</b> button and select whether you want to set <b>(Absolute)</b> or reset <b>(Reset)</b> the parameter. Some selections will not be available when you reset the parameter.</li> <li>4. In the <b>Value (%)</b> field, enter the position on the Y-axis you want to apply to the Background DVE.</li> </ol>
<b>BKGD DVE Aspect</b>	<b>Switcher &gt; Bkgd DVE &gt; Bkgd DVE Crop Param</b>	<p>Set the aspect ratio of the background DVE for the selected Canvas.</p> <ol style="list-style-type: none"> <li>1. Click the <b>ME</b> button for the Canvas that you want to perform the event on.</li> <li>2. Click the <b>Parameter</b> button and select <b>Aspect</b></li> <li>3. Click the <b>Change Type</b> button and select whether you want to set <b>(Absolute)</b> or reset <b>(Reset)</b> the parameter. Some selections will not be available when you reset the parameter.</li> <li>4. In the <b>Value (%)</b> field, enter the aspect ratio you want to apply to the Background DVE.</li> </ol>
<b>BKGD DVE Border Size</b>	<b>Switcher &gt; Bkgd DVE &gt; Bkgd DVE Crop Param</b>	<p>Set the size of the border of the background DVE for the selected Canvas.</p> <ol style="list-style-type: none"> <li>1. Click the <b>ME</b> button for the Canvas that you want to perform the event on.</li> <li>2. Click the <b>Parameter</b> button and select <b>Edge Size</b></li> <li>3. Click the <b>Change Type</b> button and select whether you want to set <b>(Absolute)</b> or reset <b>(Reset)</b> the parameter. Some selections will not be available when you reset the parameter.</li> <li>4. In the <b>Value (%)</b> field, enter the size of the border you want to apply to the Background DVE. When a border is set to 0 the border is not visible.</li> </ol>



Event	Location	Description
<b>BKGD DVE Edge Softness</b>	<b>Switcher &gt; Bkgd DVE &gt; Bkgd DVE Crop Param</b>	<p>Set the softness of the edge of the background DVE for the selected Canvas.</p> <ol style="list-style-type: none"> <li>1. Click the <b>ME</b> button for the Canvas that you want to perform the event on.</li> <li>2. Click the <b>Parameter</b> button and select <b>Edge Softness</b></li> <li>3. Click the <b>Change Type</b> button and select whether you want to set (<b>Absolute</b>) or reset (<b>Reset</b>) the parameter. Some selections will not be available when you reset the parameter.</li> <li>4. In the <b>Value (%)</b> field, enter the amount of softness to apply to the edge of the Background DVE.</li> </ol>
<b>BKGD DVE Crop</b>	<b>Switcher &gt; Bkgd DVE &gt; Bkgd DVE Crop Param</b>	<p>Set the amount of cropping you want to apply to each edge of the background DVE for the selected Canvas.</p> <ol style="list-style-type: none"> <li>1. Click the <b>ME</b> button for the Canvas that you want to perform the event on.</li> <li>2. Click the <b>Parameter</b> button and select the edge you want to crop.</li> <li>3. Click the <b>Change Type</b> button and select whether you want to set (<b>Absolute</b>) or reset (<b>Reset</b>) the parameter. Some selections will not be available when you reset the parameter.</li> <li>4. In the <b>Value (%)</b> field, enter the amount of cropping you want to apply to the selected edge of the Background DVE.</li> </ol>

## Custom Control Events

Event	Location	Description
<b>Cancel All CC</b>	<b>Custom Control &gt; Cancel All</b>	Stop all running custom controls.
<b>Cancel CC</b>	<b>Custom Control &gt; Cancel CC</b>	<p>Stop a particular custom control. The specific custom control is set when the cancel is inserted.</p> <ol style="list-style-type: none"> <li>1. Click the <b>Bank</b> button and select the custom control bank you want to cancel a custom control on.</li> <li>2. Click the <b>CC</b> button and select the custom control you want to cancel.</li> </ol>
<b>Hold CC</b>	<b>Custom Control &gt; Hold</b>	Insert a command in a custom control that will stop the custom control at the hold event. You must press the custom control button again, or use a GPI trigger, to continue the custom control.
<b>Loop CC</b>	<b>Custom Control &gt; Loop</b>	Have a custom control run continuously until stopped, or a Cancel/Cancel All custom control command is executed from another custom control.
<b>Pause CC</b>	<b>Custom Control &gt; Hold</b>	<p>Insert a command in a custom control that will stop a custom control at the pause event. The length of the pause is set when the pause is inserted.</p> <ol style="list-style-type: none"> <li>1. Enter the length of the pause in the <b>Pause (fr)</b> field.</li> </ol>
<b>Play CC</b>	<b>Custom Control &gt; Play CC</b>	<p>Play a custom control. <b>Note:</b> The Play CC command applies to a target custom control button only. If you move the contents of the custom control from the button selected in the Play CC to another button, the Play CC command will not follow and will continue to play the custom control assigned to the original button.</p> <ol style="list-style-type: none"> <li>1. Click the <b>Bank</b> button and select the custom control bank you want to play a custom control on.</li> <li>2. Click the <b>CC</b> button and select the custom control you want to play.</li> </ol>
<b>Resume CC</b>	<b>Custom Control &gt; Resume CC</b>	<p>Resume a particular custom control that is at a hold. The specific custom control is set when the resume is inserted. If the target custom control is not at a hold event, the resume command will not start the target custom control.</p> <ol style="list-style-type: none"> <li>1. Click the <b>Bank</b> button and select the custom control bank you want to resume a custom control on.</li> <li>2. Click the <b>CC</b> button and select the custom control you want to resume.</li> </ol>

Event	Location	Description
Resume All CCs	Custom Control > Resume All	Resume all custom control that are at hold. The specific custom control is set when the resume is inserted. If a custom control is not at a hold event, the resume command will not start the a custom control.
State, Insert	Custom Control > State	Embed the state of the switcher into a custom control. A state in a custom control behaves just like a memory. <ol style="list-style-type: none"> <li>Click <b>State Attributes</b> and select the elements that you want to include in the state of the switcher when it is stored to the custom control. If <b>Disable Audio Memories</b> is set to <b>On</b> (Click <b>Navigation Menu &gt; Configuration &gt; System &gt; Global</b>) the audio attributes are disabled.</li> </ol>

## Keyer

Event	Location	Description
Key Only Transition	Switcher > Keyer > Keyer Trans	Perform a key only transition for the selected area. <ol style="list-style-type: none"> <li>Click the <b>ME</b> button and select the area that you want to perform the event on.</li> <li>Click the <b>Keyer</b> button for the key you want to perform the event on.</li> <li>Click the <b>Action</b> button and select the type of transition to perform. <ul style="list-style-type: none"> <li><b>Cut</b> — cut transition</li> <li><b>Auto</b> — auto transition</li> <li><b>Reset Rate</b> — reset the transition rate to default</li> <li><b>Cut On</b> — cut the key on-air</li> <li><b>Cut Off</b> — cut the key off-air</li> <li><b>Auto Trans On</b> — auto transition the key on-air</li> <li><b>Auto Trans Off</b> — auto transition the key off-air</li> </ul> </li> </ol>
Key Trans Rate	Switcher > Keyer > Keyer Trans Rate	Set or reset the keyer transition rate of the selected area. <ol style="list-style-type: none"> <li>Click the <b>ME</b> button and select the area that you want to perform the event on.</li> <li>Click the <b>Keyer</b> button for the key you want to perform the event on.</li> <li>Click the <b>Change Type</b> button and select whether you want to set (<b>Absolute</b>) or reset (<b>Reset</b>) the parameter. Some selections will not be available when you reset the parameter.</li> <li>Enter a new transition rate, in frames, for the key in the <b>Value (fr)</b> field.</li> </ol>
Chroma Key, Initialize	Switcher > Keyer > Chroma Key Init	Initialize a chroma key for the selected key for the selected area. <ol style="list-style-type: none"> <li>Click the <b>ME</b> button and select the area that you want to perform the event on.</li> </ol>
Chroma Key Auto Adjust	Switcher > Keyer > CK Auto Adjust	Select the chroma key auto adjustments that you want to turn on. <ol style="list-style-type: none"> <li>Click the <b>ME</b> button and select the area that you want to perform the event on.</li> <li>Click a <b>Parameter</b> button to select whether to toggle <b>Auto Re-Spill Color</b> or <b>Auto Edge Luma</b>.</li> <li>Click the <b>Change Type</b> button and select whether you want to set (<b>Absolute</b>) or reset (<b>Reset</b>) the parameter. Some selections will not be available when you reset the parameter.</li> <li>Click the <b>Value</b> button and select whether to turn the parameter <b>On</b> or <b>Off</b>.</li> </ol>
Chroma Key Color	Switcher > Keyer > Chroma Key Color	Select the color you want to key out for the selected key for the selected area. <ol style="list-style-type: none"> <li>Click the <b>ME</b> button and select the area that you want to perform the event on.</li> <li>Click <b>Color</b> and select the color you want to key out.</li> </ol>

Event	Location	Description
<b>Chroma Key Measurement Source</b>	<b>Switcher &gt; Keyer &gt; CK Measurement Source</b>	Select the video source that you want to use for the automatic adjustment of the chroma key. <ol style="list-style-type: none"> <li>1. Click the <b>ME</b> button and select the area that you want to perform the event on.</li> <li>2. Click the <b>Value</b> button and select video source you want to use.</li> </ol>
<b>Chroma Key Re-spill Color</b>	<b>Switcher &gt; Keyer &gt; CK Color (Preset Color)</b>	Select the re-spill color for the chroma key. <ol style="list-style-type: none"> <li>1. Click the <b>ME</b> button and select the area that you want to perform the event on.</li> <li>2. Click the <b>Color</b> button and select the re-spill color.</li> </ol>
<b>Chroma Key Re-spill Saturation</b>	<b>Switcher &gt; Keyer &gt; CK Color (HSL Color)</b>	Select the re-spill saturation for the chroma key. <ol style="list-style-type: none"> <li>1. Click the <b>ME</b> button and select the area that you want to perform the event on.</li> <li>2. Click the <b>Component</b> button and select <b>Sat</b>.</li> <li>3. Click the <b>Change Type</b> button and select whether you want to set <b>(Absolute)</b> or reset <b>(Reset)</b> the parameter. Some selections will not be available when you reset the parameter.</li> <li>4. Click the <b>Value</b> button and select the new value you want to enter for the selected component.</li> </ol>
<b>Chroma Key Setup</b>	<b>Switcher &gt; Keyer &gt; UCHR Param</b>	Select the various advanced chroma key settings for the selected key for the selected area. <ol style="list-style-type: none"> <li>1. Click the <b>ME</b> button and select the area that you want to perform the event on.</li> <li>2. Click the <b>UCHR Controls</b> button and select the parameter you want to adjust.</li> <li>3. Click the <b>Change Type</b> button and select whether you want to set <b>(Absolute)</b> or reset <b>(Reset)</b> the parameter. Some selections will not be available when you reset the parameter.</li> <li>4. Click the <b>Value</b> button and select the new value you want to enter for the selected parameter.</li> </ol>
<b>DVE Freeze</b>	<b>Switcher &gt; Keyer &gt; DVE Freeze</b>	Turn the DVE freeze feature on or off for the selected key for the selected ME, MiniME™, or Canvas. <ol style="list-style-type: none"> <li>1. Click the <b>ME</b> button and select the area that you want to perform the event on.</li> <li>2. Click the <b>Keyer</b> button for the key you want to perform the event on.</li> <li>3. Click the <b>Change Type</b> button and select whether you want to set <b>(Absolute)</b> or reset <b>(Reset)</b> the parameter. Some selections will not be available when you reset the parameter.</li> <li>4. Click the <b>Value</b> button and select whether to freeze the video and appearance of a key <b>(On)</b> or not <b>(Off)</b>. When a key is frozen, the DVE attribute are disabled and you can not move the key.</li> </ol>
<b>DVE Key Aspect</b>	<b>Switcher &gt; Keyer &gt; DVE Param</b>	Select the aspect ratio for the DVE key on the selected key for the selected ME. <ol style="list-style-type: none"> <li>1. Click the <b>ME</b> button for the ME that you want to perform the event on.</li> <li>2. Click the <b>Keyer</b> button for the key you want to perform the event on.</li> <li>3. Click the <b>Parameter</b> button and select <b>Aspect</b>.</li> <li>4. Click the <b>Change Type</b> button and select whether you want to set <b>(Absolute)</b> or reset <b>(Reset)</b> the parameter. Some selections will not be available when you reset the parameter.</li> <li>5. Enter an aspect ratio in the <b>Value (%)</b> field.</li> </ol>

Event	Location	Description
<b>DVE Key Border Color (HSL)</b>	<b>Switcher &gt; Keyer &gt; DVE Border Color (HSL)</b>	<p>Select the custom color you want to apply to the border of the DVE key of the selected area. Each component of the HSL color must be inserted individually.</p> <ol style="list-style-type: none"> <li>1. Click the <b>ME</b> button and select the area that you want to perform the event on.</li> <li>2. Click the <b>Keyer</b> button for the key you want to perform the event on.</li> <li>3. Click the <b>Change Type</b> button and select whether you want to set (<b>Absolute</b>) or reset (<b>Reset</b>) the parameter. Some selections will not be available when you reset the parameter.</li> <li>4. Click the <b>Component</b> button and select the HSL component you want to assign a value to. A value should be applied to all three components.</li> <li>5. Enter a value for the selected component in the <b>Value (%)</b> field.</li> </ol>
<b>DVE Key Border Color (Preset)</b>	<b>Switcher &gt; Keyer &gt; DVE Border Color (Preset)</b>	<p>Select the preset color you want to apply to the border of the DVE key of the selected key for the selected area.</p> <ol style="list-style-type: none"> <li>1. Click the <b>ME</b> button and select the area that you want to perform the event on.</li> <li>2. Click the <b>Keyer</b> button for the key you want to perform the event on.</li> <li>3. Click the <b>Color</b> button and select the preset color you want to apply to the border.</li> </ol>
<b>DVE Key Border</b>	<b>Switcher &gt; Keyer &gt; DVE Param</b>	<p>Select the size of border for the DVE key on the selected key for the selected ME.</p> <ol style="list-style-type: none"> <li>1. Click the <b>ME</b> button for the ME that you want to perform the event on.</li> <li>2. Click the <b>Keyer</b> button for the key you want to perform the event on.</li> <li>3. Click the <b>Parameter</b> button and select <b>Edge Size</b>.</li> <li>4. Click the <b>Change Type</b> button and select whether you want to set (<b>Absolute</b>) or reset (<b>Reset</b>) the parameter. Some selections will not be available when you reset the parameter.</li> <li>5. Enter a size for the border in the <b>Value (%)</b> field.</li> </ol>
<b>DVE Key Crop (Bottom Edge)</b>	<b>Switcher &gt; Keyer &gt; DVE Param</b>	<p>Select the amount of cropping on the bottom edge of the DVE key on the selected key for the selected ME.</p> <ol style="list-style-type: none"> <li>1. Click the <b>ME</b> button for the ME that you want to perform the event on.</li> <li>2. Click the <b>Keyer</b> button for the key you want to perform the event on.</li> <li>3. Click the <b>Parameter</b> button and select <b>Bottom Edge</b>.</li> <li>4. Click the <b>Change Type</b> button and select whether you want to set (<b>Absolute</b>) or reset (<b>Reset</b>) the parameter. Some selections will not be available when you reset the parameter.</li> <li>5. Enter the amount of cropping in the <b>Value (%)</b> field.</li> </ol>
<b>DVE Key Crop (Dual Edge)</b>	<b>Switcher &gt; Keyer &gt; DVE Crop Param</b>	<p>Select the amount of cropping on both horizontal or vertical edges of the DVE key of the selected key for the selected area.</p> <ol style="list-style-type: none"> <li>1. Click the <b>ME</b> button and select the area that you want to perform the event on.</li> <li>2. Click the <b>Keyer</b> button for the key you want to perform the event on.</li> <li>3. Click the <b>Change Type</b> button and select whether you want to set (<b>Absolute</b>) or reset (<b>Reset</b>) the parameter. Some selections will not be available when you reset the parameter.</li> <li>4. Click the <b>Parameter</b> button and select the edges you want to crop.</li> <li>5. Enter the amount of Left or Top cropping you want to apply in the <b>Value %</b> field.</li> <li>6. Enter the amount of Right or Bottom cropping you want to apply in the <b>Other Value %</b> field.</li> </ol>

Event	Location	Description
<b>DVE Key Crop (Left Edge)</b>	<b>Switcher &gt; Keyer &gt; DVE Param</b>	<p>Select the amount of cropping on the left edge of the DVE key on the selected key for the selected ME.</p> <ol style="list-style-type: none"> <li>1. Click the <b>ME</b> button for the ME that you want to perform the event on.</li> <li>2. Click the <b>Keyer</b> button for the key you want to perform the event on.</li> <li>3. Click the <b>Parameter</b> button and select <b>Left Edge</b>.</li> <li>4. Click the <b>Change Type</b> button and select whether you want to set <b>(Absolute)</b> or reset <b>(Reset)</b> the parameter. Some selections will not be available when you reset the parameter.</li> <li>5. Enter the amount of cropping in the <b>Value (%)</b> field.</li> </ol>
<b>DVE Key Crop (Right Edge)</b>	<b>Switcher &gt; Keyer &gt; DVE Param</b>	<p>Select the amount of cropping on the right edge of the DVE key on the selected key for the selected ME.</p> <ol style="list-style-type: none"> <li>1. Click the <b>ME</b> button for the ME that you want to perform the event on.</li> <li>2. Click the <b>Keyer</b> button for the key you want to perform the event on.</li> <li>3. Click the <b>Parameter</b> button and select <b>Right Edge</b>.</li> <li>4. Click the <b>Change Type</b> button and select whether you want to set <b>(Absolute)</b> or reset <b>(Reset)</b> the parameter. Some selections will not be available when you reset the parameter.</li> <li>5. Enter the amount of cropping in the <b>Value (%)</b> field.</li> </ol>
<b>DVE Key Crop (Top Edge)</b>	<b>Switcher &gt; Keyer &gt; DVE Param</b>	<p>Select the amount of cropping on the top edge of the DVE key on the selected key for the selected ME.</p> <ol style="list-style-type: none"> <li>1. Click the <b>ME</b> button for the ME that you want to perform the event on.</li> <li>2. Click the <b>Keyer</b> button for the key you want to perform the event on.</li> <li>3. Click the <b>Parameter</b> button and select <b>Top Edge</b>.</li> <li>4. Click the <b>Change Type</b> button and select whether you want to set <b>(Absolute)</b> or reset <b>(Reset)</b> the parameter. Some selections will not be available when you reset the parameter.</li> <li>5. Enter the amount of cropping in the <b>Value (%)</b> field.</li> </ol>
<b>DVE Key Edge Softness</b>	<b>Switcher &gt; Keyer &gt; DVE Param</b>	<p>Select the amount of softness to apply to the edge of the DVE key on the selected key for the selected ME.</p> <ol style="list-style-type: none"> <li>1. Click the <b>ME</b> button for the ME that you want to perform the event on.</li> <li>2. Click the <b>Keyer</b> button for the key you want to perform the event on.</li> <li>3. Click the <b>Parameter</b> button and select <b>Edge Softness</b>.</li> <li>4. Click the <b>Change Type</b> button and select whether you want to set <b>(Absolute)</b> or reset <b>(Reset)</b> the parameter. Some selections will not be available when you reset the parameter.</li> <li>5. Enter an amount of softness for the DVE key or border in the <b>Value (%)</b> field.</li> </ol>
<b>DVE Key Size</b>	<b>Switcher &gt; Keyer &gt; DVE Param</b>	<p>Select the size of the DVE key on the selected key for the selected ME.</p> <ol style="list-style-type: none"> <li>1. Click the <b>ME</b> button for the ME that you want to perform the event on.</li> <li>2. Click the <b>Keyer</b> button for the key you want to perform the event on.</li> <li>3. Click the <b>Parameter</b> button and select <b>Size</b>.</li> <li>4. Click the <b>Change Type</b> button and select whether you want to set <b>(Absolute)</b> or reset <b>(Reset)</b> the parameter. Some selections will not be available when you reset the parameter.</li> <li>5. Enter a new size in the <b>Value (%)</b> field.</li> </ol>

Event	Location	Description
DVE Key X-Position	Switcher > Keyer > DVE Param	<p>Select the x-axis position of the DVE key on the selected key for the selected ME.</p> <ol style="list-style-type: none"> <li>1. Click the <b>ME</b> button for the ME that you want to perform the event on.</li> <li>2. Click the <b>Keyer</b> button for the key you want to perform the event on.</li> <li>3. Click the <b>Parameter</b> button and select <b>X-Pos</b>.</li> <li>4. Click the <b>Change Type</b> button and select whether you want to set (<b>Absolute</b>) or reset (<b>Reset</b>) the parameter. Some selections will not be available when you reset the parameter.</li> <li>5. Enter a new position in the <b>Value (%)</b> field.</li> </ol>
DVE Key Y-Position	Switcher > Keyer > DVE Param	<p>Select the y-axis position for the DVE key on the selected key for the selected ME.</p> <ol style="list-style-type: none"> <li>1. Click the <b>ME</b> button for the ME that you want to perform the event on.</li> <li>2. Click the <b>Keyer</b> button for the key you want to perform the event on.</li> <li>3. Click the <b>Parameter</b> button and select <b>Y-Pos</b>.</li> <li>4. Click the <b>Change Type</b> button and select whether you want to set (<b>Absolute</b>) or reset (<b>Reset</b>) the parameter. Some selections will not be available when you reset the parameter.</li> <li>5. Enter a new position in the <b>Value (%)</b> field.</li> </ol>
Fly Key (DVE)	Switcher > Keyer > Keyer Fly	<p>Assign DVE resources (Fly) to the selected key for the selected area.</p> <ol style="list-style-type: none"> <li>1. Click the <b>ME</b> button and select the area that you want to perform the event on.</li> <li>2. Click the <b>Keyer</b> button for the key you want to perform the event on.</li> <li>3. Click the <b>Change Type</b> button and select whether you want to set (<b>Absolute</b>) or reset (<b>Reset</b>) the parameter. Some selections will not be available when you reset the parameter.</li> <li>4. Click the <b>Value</b> button and select whether DVE resources are assigned to the key (<b>On</b>) or not (<b>Off</b>).</li> </ol>
Key, Make Linear	Switcher > Keyer > Keyer Make Linear	<p>Make the selected key linear on the selected area.</p> <ol style="list-style-type: none"> <li>1. Click the <b>ME</b> button and select the area that you want to perform the event on.</li> <li>2. Click the <b>Keyer</b> button for the key you want to make linear.</li> </ol>
Key Active	Switcher > Keyer > Keyer Active	<p>Transition a key (or include it in the next transition) on or off-air for the selected area.</p> <ol style="list-style-type: none"> <li>1. Click the <b>ME</b> button and select the area that you want to perform the event on.</li> <li>2. Click the <b>Keyer</b> button for the key you want to perform the event on.</li> <li>3. Click the <b>Change Type</b> button and select whether you want to set (<b>Absolute</b>) or reset (<b>Reset</b>) the parameter. Some selections will not be available when you reset the parameter.</li> <li>4. Click the <b>Parameter</b> button and select a cut (<b>Cut Key</b>) or auto transition (<b>Trans Key</b>) for the key, or have to key included in the next transition (<b>Include Key</b>).</li> <li>5. Click the <b>Value</b> button to select whether the key is transitioned on-air / included in the next transition to go on-air (<b>On</b>) or off-air / included in the next transition to go off-air (<b>Off</b>).</li> </ol>
Key Copy	Switcher > Keyer > Keyer Copy	<p>Copy the contents of one key to another key the same or a different area.</p> <ol style="list-style-type: none"> <li>1. Click the <b>Target ME</b> button and select where you want to copy the key to.</li> <li>2. Click the <b>Target Keyer</b> button for the key you want to copy to.</li> <li>3. Click the <b>Source ME</b> button and select where you want to copy the key from.</li> <li>4. Click the <b>Source Keyer</b> button for the key you want to copy from.</li> </ol>

Event	Location	Description
<b>Key Invert</b>	<b>Switcher &gt; Keyer &gt; Keyer Invert</b>	Turn the key invert feature on or off for the selected key for the selected area. <ol style="list-style-type: none"> <li>1. Click the <b>ME</b> button and select the area that you want to perform the event on.</li> <li>2. Click the <b>Keyer</b> button for the key you want to reverse the polarity of the key alpha so that the holes in the background are cut by dark areas of the key alpha instead of bright areas.</li> <li>3. Click the <b>Change Type</b> button and select whether you want to set (<b>Absolute</b>) or reset (<b>Reset</b>) the parameter. Some selections will not be available when you reset the parameter.</li> <li>4. Click a <b>Value</b> button to turn key invert on (<b>On</b>) or off (<b>Off</b>).</li> </ol>
<b>Key Mode</b>	<b>Switcher &gt; Keyer &gt; Keyer Mode</b>	Select the mode for the selected key for the selected area. <ol style="list-style-type: none"> <li>1. Click the <b>ME</b> button and select the area that you want to perform the event on.</li> <li>2. Click the <b>Keyer</b> button for the key you want to perform the event on.</li> <li>3. Click a <b>Mode</b> button to have the key set as shaped/unshaped from the key (<b>Normal</b>), as additive for a shaped source (<b>Additive</b>), or alpha to fully opaque/white (<b>Full</b>).</li> </ol>
<b>Key Reset</b>	<b>Switcher &gt; Keyer &gt; Keyer Reset Params</b>	Reset the parameters for the selected key for the selected area. <ol style="list-style-type: none"> <li>1. Click the <b>ME</b> button and select the area that you want to perform the event on.</li> <li>2. Click the <b>Keyer</b> button for the key you want to reset the clip, gain, transparency, invert, and mask for.</li> </ol>
<b>Key Settings (Clip, Gain, Transparency)</b>	<b>Switcher &gt; Keyer &gt; Keyer Settings</b>	Select clip, gain, and transparency settings for the selected key for the selected area. <ol style="list-style-type: none"> <li>1. Click the <b>ME</b> button and select the area that you want to perform the event on.</li> <li>2. Click the <b>Keyer</b> button for the key you want to perform the event on.</li> <li>3. Click the <b>Change Type</b> button and select whether you want to set (<b>Absolute</b>) or reset (<b>Reset</b>) the parameter. Some selections will not be available when you reset the parameter.</li> <li>4. Enter a value for the clip, gain, or transparency for the key in the <b>Value</b> field.</li> </ol>
<b>Key Swap</b>	<b>Switcher &gt; Keyer &gt; Keyer Swap</b>	Swap the contents of one key with another key the same or a different area. <ol style="list-style-type: none"> <li>1. Click the <b>1st ME</b> button and select where the first key you want to swap is.</li> <li>2. Click the <b>1st Keyer</b> button for the first key you want to swap.</li> <li>3. Click the <b>2nd ME</b> button and select where the second key you want to swap is.</li> <li>4. Click the <b>2nd Keyer</b> button for the second key you want to swap.</li> </ol>
<b>Key Type</b>	<b>Switcher &gt; Keyer &gt; Keyer Type</b>	Assign a key type for a key for the selected area. <ol style="list-style-type: none"> <li>1. Click the <b>ME</b> button and select the area that you want to perform the event on.</li> <li>2. Click the <b>Keyer</b> button for the key you want to perform the event on.</li> <li>3. Click a <b>Type</b> button to assign the key type to the selected key.</li> </ol>
<b>Mask, Force</b>	<b>Switcher &gt; Keyer &gt; Mask Force</b>	Apply a mask to the selected key for the selected ME. <ol style="list-style-type: none"> <li>1. Click the <b>ME</b> button for the ME that you want to perform the event on.</li> <li>2. Click the <b>Keyer</b> button for the key you want to perform the event on.</li> <li>3. Click the <b>Change Type</b> button and select whether you want to set (<b>Absolute</b>) or reset (<b>Reset</b>) the parameter. Some selections will not be available when you reset the parameter.</li> <li>4. Click the <b>Value</b> button and select whether to force the area inside the mask region to the foreground (<b>On</b>) or not (<b>Off</b>).</li> </ol>

Event	Location	Description
Mask, Invert	Switcher > Keyer > Mask Invert	<p>Invert the mask of the selected key for the selected ME.</p> <ol style="list-style-type: none"> <li>1. Click the <b>ME</b> button for the ME that you want to perform the event on.</li> <li>2. Click the <b>Keyer</b> button for the key you want to perform the event on.</li> <li>3. Click the <b>Change Type</b> button and select whether you want to set <b>(Absolute)</b> or reset <b>(Reset)</b> the parameter. Some selections will not be available when you reset the parameter.</li> <li>4. Click the <b>Value</b> button and select whether to invert the masked area with the unmasked area <b>(On)</b> or not <b>(Off)</b>.</li> </ol>
Mask (Box) — Bottom Edge Position	Switcher > Keyer > Box Mask Param	<p>Select the position for the bottom edge of the box mask on the selected key for the selected ME.</p> <ol style="list-style-type: none"> <li>1. Click the <b>ME</b> button for the ME that you want to perform the event on.</li> <li>2. Click the <b>Keyer</b> button for the key you want to perform the event on.</li> <li>3. Click the <b>Parameter</b> button and select <b>Bottom Edge</b>.</li> <li>4. Click the <b>Change Type</b> button and select whether you want to set <b>(Absolute)</b> or reset <b>(Reset)</b> the parameter. Some selections will not be available when you reset the parameter.</li> <li>5. Enter a new position in the <b>Value (%)</b> field.</li> </ol>
Mask (Box) — Edge Softness	Switcher > Keyer > Box Mask Param	<p>Select the amount of softness to apply to the edges of the box mask on the selected key for the selected ME.</p> <ol style="list-style-type: none"> <li>1. Click the <b>ME</b> button for the ME that you want to perform the event on.</li> <li>2. Click the <b>Keyer</b> button for the key you want to perform the event on.</li> <li>3. Click the <b>Parameter</b> button and select <b>Edge Softness</b>.</li> <li>4. Click the <b>Change Type</b> button and select whether you want to set <b>(Absolute)</b> or reset <b>(Reset)</b> the parameter. Some selections will not be available when you reset the parameter.</li> <li>5. Enter a new softness amount in the <b>Value (%)</b> field.</li> </ol>
Mask (Box) — Left Edge Position	Switcher > Keyer > Box Mask Param	<p>Select the position for the left edge of the box mask on the selected key for the selected ME.</p> <ol style="list-style-type: none"> <li>1. Click the <b>ME</b> button for the ME that you want to perform the event on.</li> <li>2. Click the <b>Keyer</b> button for the key you want to perform the event on.</li> <li>3. Click the <b>Parameter</b> button and select <b>Left Edge</b>.</li> <li>4. Click the <b>Change Type</b> button and select whether you want to set <b>(Absolute)</b> or reset <b>(Reset)</b> the parameter. Some selections will not be available when you reset the parameter.</li> <li>5. Enter a new position in the <b>Value (%)</b> field.</li> </ol>
Mask (Box) — Right Edge Position	Switcher > Keyer > Box Mask Param	<p>Select the position for the right edge of the box mask on the selected key for the selected ME.</p> <ol style="list-style-type: none"> <li>1. Click the <b>ME</b> button for the ME that you want to perform the event on.</li> <li>2. Click the <b>Keyer</b> button for the key you want to perform the event on.</li> <li>3. Click the <b>Parameter</b> button and select <b>Right Edge</b>.</li> <li>4. Click the <b>Change Type</b> button and select whether you want to set <b>(Absolute)</b> or reset <b>(Reset)</b> the parameter. Some selections will not be available when you reset the parameter.</li> <li>5. Enter a new position in the <b>Value (%)</b> field.</li> </ol>
Mask (Box) — Size	Switcher > Keyer > Box Mask Param	<p>Select the size of the box mask on the selected key for the selected ME.</p> <ol style="list-style-type: none"> <li>1. Click the <b>ME</b> button for the ME that you want to perform the event on.</li> <li>2. Click the <b>Keyer</b> button for the key you want to perform the event on.</li> <li>3. Click the <b>Parameter</b> button and select <b>Size</b>.</li> <li>4. Click the <b>Change Type</b> button and select whether you want to set <b>(Absolute)</b> or reset <b>(Reset)</b> the parameter. Some selections will not be available when you reset the parameter.</li> <li>5. Enter a new size in the <b>Value (%)</b> field.</li> </ol>



Event	Location	Description
<b>Mask (Box) — Top Edge Position</b>	<b>Switcher &gt; Keyer &gt; Box Mask Param</b>	<p>Select the position for the top edge of the box mask on the selected key for the selected ME.</p> <ol style="list-style-type: none"> <li>1. Click the <b>ME</b> button for the ME that you want to perform the event on.</li> <li>2. Click the <b>Keyer</b> button for the key you want to perform the event on.</li> <li>3. Click the <b>Parameter</b> button and select <b>Top Edge</b>.</li> <li>4. Click the <b>Change Type</b> button and select whether you want to set (<b>Absolute</b>) or reset (<b>Reset</b>) the parameter. Some selections will not be available when you reset the parameter.</li> <li>5. Enter a new position in the <b>Value (%)</b> field.</li> </ol>
<b>Mask (Box) — X-Position</b>	<b>Switcher &gt; Keyer &gt; Box Mask Param</b>	<p>Select the x-axis position of the box mask on the selected key for the selected ME.</p> <ol style="list-style-type: none"> <li>1. Click the <b>ME</b> button for the ME that you want to perform the event on.</li> <li>2. Click the <b>Keyer</b> button for the key you want to perform the event on.</li> <li>3. Click the <b>Parameter</b> button and select <b>X-Pos</b>.</li> <li>4. Click the <b>Change Type</b> button and select whether you want to set (<b>Absolute</b>) or reset (<b>Reset</b>) the parameter. Some selections will not be available when you reset the parameter.</li> <li>5. Enter a new position in the <b>Value (%)</b> field.</li> </ol>
<b>Mask (Box) — Y-Position</b>	<b>Switcher &gt; Keyer &gt; Box Mask Param</b>	<p>Select the y-axis position for the box mask on the selected key for the selected ME.</p> <ol style="list-style-type: none"> <li>1. Click the <b>ME</b> button for the ME that you want to perform the event on.</li> <li>2. Click the <b>Keyer</b> button for the key you want to perform the event on.</li> <li>3. Click the <b>Parameter</b> button and select <b>Y-Pos</b>.</li> <li>4. Click the <b>Change Type</b> button and select whether you want to set (<b>Absolute</b>) or reset (<b>Reset</b>) the parameter. Some selections will not be available when you reset the parameter.</li> <li>5. Enter a new position in the <b>Value (%)</b> field.</li> </ol>
<b>Mask (Pattern) — Aspect Ratio</b>	<b>Switcher &gt; Keyer &gt; Pattern Mask Param</b>	<p>Select the aspect ratio for the pattern mask for the selected ME.</p> <ol style="list-style-type: none"> <li>1. Click the <b>ME</b> button for the ME that you want to perform the event on.</li> <li>2. Click the <b>Parameter</b> button and select <b>Aspect</b>.</li> <li>3. Click the <b>Change Type</b> button and select whether you want to set (<b>Absolute</b>) or reset (<b>Reset</b>) the parameter. Some selections will not be available when you reset the parameter.</li> <li>4. Enter an aspect ratio in the <b>Value (%)</b> field.</li> </ol>
<b>Mask (Pattern) — Border Size</b>	<b>Switcher &gt; Keyer &gt; Pattern Mask Param</b>	<p>Select the size of border for the pattern mask on the selected key for the selected ME.</p> <ol style="list-style-type: none"> <li>1. Click the <b>ME</b> button for the ME that you want to perform the event on.</li> <li>2. Click the <b>Parameter</b> button and select <b>Border Size</b>.</li> <li>3. Click the <b>Change Type</b> button and select whether you want to set (<b>Absolute</b>) or reset (<b>Reset</b>) the parameter. Some selections will not be available when you reset the parameter.</li> <li>4. Enter a size for the border in the <b>Value (%)</b> field.</li> </ol>
<b>Mask (Pattern) — Edge Softness</b>	<b>Switcher &gt; Keyer &gt; Pattern Mask Param</b>	<p>Select the amount of softness to apply to the edge of the mask for the selected ME.</p> <ol style="list-style-type: none"> <li>1. Click the <b>ME</b> button for the ME that you want to perform the event on.</li> <li>2. Click the <b>Parameter</b> button and select <b>Softness</b>.</li> <li>3. Click the <b>Change Type</b> button and select whether you want to set (<b>Absolute</b>) or reset (<b>Reset</b>) the parameter. Some selections will not be available when you reset the parameter.</li> <li>4. Enter an amount of softness for the pattern or border in the <b>Value (%)</b> field.</li> </ol>

Event	Location	Description
Mask (Pattern) — Horizontal Multiplication	Switcher > Keyer > Pattern Mask Param	<p>Select the number of times you want to multiply the pattern mask horizontally for the selected ME.</p> <ol style="list-style-type: none"> <li>1. Click the <b>ME</b> button for the ME that you want to perform the event on.</li> <li>2. Click the <b>Parameter</b> button and select <b>Horizontal Mult.</b></li> <li>3. Click the <b>Change Type</b> button and select whether you want to set (<b>Absolute</b>) or reset (<b>Reset</b>) the parameter. Some selections will not be available when you reset the parameter.</li> <li>4. Enter the number of times the pattern is multiplied in the <b>Value</b> field.</li> </ol>
Mask (Pattern) — Reset	Switcher > Keyer > Pattern Mask Reset	<p>Reset the mask for the selected ME.</p> <ol style="list-style-type: none"> <li>1. Click the <b>ME</b> button for the ME that you want to perform the event on.</li> <li>2. Click <b>Reset Params.</b></li> </ol>
Mask (Pattern) — Rotation	Switcher > Keyer > Pattern Mask Param	<p>Select the rotation for the pattern mask for the selected ME.</p> <ol style="list-style-type: none"> <li>1. Click the <b>ME</b> button for the ME that you want to perform the event on.</li> <li>2. Click the <b>Parameter</b> button and select <b>Rotation.</b></li> <li>3. Click the <b>Change Type</b> button and select whether you want to set (<b>Absolute</b>) or reset (<b>Reset</b>) the parameter. Some selections will not be available when you reset the parameter.</li> <li>4. Enter a rotation in the <b>Value (%)</b> field.</li> </ol>
Mask (Pattern) — Size	Switcher > Keyer > Pattern Mask Param	<p>Select the size of the pattern mask for the selected ME.</p> <ol style="list-style-type: none"> <li>1. Click the <b>ME</b> button for the ME that you want to perform the event on.</li> <li>2. Click the <b>Parameter</b> button and select <b>Size.</b></li> <li>3. Click the <b>Change Type</b> button and select whether you want to set (<b>Absolute</b>) or reset (<b>Reset</b>) the parameter. Some selections will not be available when you reset the parameter.</li> <li>4. Enter a new size in the <b>Value (%)</b> field.</li> </ol>
Mask (Pattern) — Vertical Multiplication	Switcher > Keyer > Pattern Mask Param	<p>Select the number of times you want to multiply the pattern mask vertically for the selected ME.</p> <ol style="list-style-type: none"> <li>1. Click the <b>ME</b> button for the ME that you want to perform the event on.</li> <li>2. Click the <b>Parameter</b> button and select <b>Vertical Mult.</b></li> <li>3. Click the <b>Change Type</b> button and select whether you want to set (<b>Absolute</b>) or reset (<b>Reset</b>) the parameter. Some selections will not be available when you reset the parameter.</li> <li>4. Enter the number of times the pattern is multiplied in the <b>Value</b> field.</li> </ol>
Mask (Pattern) — X-Position	Switcher > Keyer > Pattern Mask Param	<p>Select the x-axis position of the pattern mask for the selected ME.</p> <ol style="list-style-type: none"> <li>1. Click the <b>ME</b> button for the ME that you want to perform the event on.</li> <li>2. Click the <b>Parameter</b> button and select <b>X-Pos.</b></li> <li>3. Click the <b>Change Type</b> button and select whether you want to set (<b>Absolute</b>) or reset (<b>Reset</b>) the parameter. Some selections will not be available when you reset the parameter.</li> <li>4. Enter a new position in the <b>Value (%)</b> field.</li> </ol>
Mask (Pattern) — Y-Position	Switcher > Keyer > Pattern Mask Param	<p>Select the y-axis position for the pattern mask for the selected ME.</p> <ol style="list-style-type: none"> <li>1. Click the <b>ME</b> button for the ME that you want to perform the event on.</li> <li>2. Click the <b>Parameter</b> button and select <b>Y-Pos.</b></li> <li>3. Click the <b>Change Type</b> button and select whether you want to set (<b>Absolute</b>) or reset (<b>Reset</b>) the parameter. Some selections will not be available when you reset the parameter.</li> <li>4. Enter a new position in the <b>Value (%)</b> field.</li> </ol>

Event	Location	Description
Mask	Switcher > Keyer > Mask Type	Apply a mask to the selected key for the selected ME. <ol style="list-style-type: none"> <li>1. Click the <b>ME</b> button for the ME that you want to perform the event on.</li> <li>2. Click the <b>Keyer</b> button for the key you want to perform the event on.</li> <li>3. Click a <b>Mask Type</b> button to apply a pattern mask (<b>Pattern</b>), box mask (<b>Box</b>, or turn the mask off (<b>Off</b>).</li> </ol>

## Media-Store

Event	Location	Description
Auto Play	Switcher > Media-Store > Attributes	Select whether an animation plays automatically when taken on-air for the selected Media-Store channel. <ol style="list-style-type: none"> <li>1. Click the <b>MediaStore Channel</b> button for the Media-Store channel you want to perform the event on.</li> <li>2. Click the <b>Change Type</b> button and select whether you want to set (<b>Absolute</b>) or reset (<b>Reset</b>) the parameter. Some selections will not be available when you reset the parameter.</li> <li>3. Click the <b>Parameter</b> button and select <b>Auto Play</b>.</li> <li>4. Click the <b>Value</b> button and select whether the animation plays automatically (<b>On</b>) or not (<b>Off</b>).</li> </ol>
Capture Alpha	Switcher > Media-Store > Capture Alpha	Select whether to include the alpha with a capture on the selected Media-Store channel. <ol style="list-style-type: none"> <li>1. Click the <b>MediaStore Channel</b> button for the Media-Store channel you want to perform the event on.</li> <li>2. Click the <b>Capture Alpha</b> button and select whether the alpha is captured with the source (<b>Yes</b>) or not (<b>No</b>).</li> </ol>
Capture Alpha Source	Switcher > Media-Store > Capture Alpha Source	Select the alpha source you want to capture for the selected Media-Store channel. <ol style="list-style-type: none"> <li>1. Click the <b>MediaStore Channel</b> button for the Media-Store channel you want to perform the event on.</li> <li>2. Click <b>Source</b> and select the alpha source that you want to capture.</li> </ol>
Capture	Switcher > Media-Store > Capture	Capture a still to the selected Media-Store channel. <ol style="list-style-type: none"> <li>1. Click the <b>MediaStore Channel</b> button for the Media-Store channel you want to perform the event on.</li> <li>2. Click a <b>Capture Type</b> button to select whether the Media-Store captures the media to a file name (<b>Capture</b>) or the next available capture number (<b>Capture+</b>).</li> <li>3. If you selected <b>Capture</b>, enter the name you want use for the capture file in the <b>Capture File Name</b> field. If a file with the same name exists it will be overwritten.</li> </ol>
Capture Mode	Switcher > Media-Store > Capture Display	Select the capture mode for the selected Media-Store channel. <ol style="list-style-type: none"> <li>1. Click the <b>MediaStore Channel</b> button for the Media-Store channel you want to perform the event on.</li> <li>2. Click a <b>Capture Display</b> button to select whether the capture is in electronic-to-electronic "E/E" (<b>End to End</b>) or playback "P/B" (<b>Playback</b>) mode.</li> </ol>
Capture Source	Switcher > Media-Store > Capture Source	Select the video source you want to capture for the selected Media-Store channel. <ol style="list-style-type: none"> <li>1. Click the <b>MediaStore Channel</b> button for the Media-Store channel you want to perform the event on.</li> <li>2. Click <b>Source</b> and select the video source that you want to capture.</li> </ol>

Event	Location	Description
<b>Clear Channel</b>	<b>Switcher &gt; Media-Store &gt; Channel Action</b>	Clear the selected Media-Store channel. <ol style="list-style-type: none"> <li>1. Click the <b>MediaStore Channel</b> button for the Media-Store channel you want to perform the event on.</li> <li>2. Click <b>Clear Channel</b>.</li> </ol>
<b>Cut Frame</b>	<b>Switcher &gt; Media-Store &gt; Attributes</b>	Select the point, in frames, from the start of the media item that the MediaWipe background cut occurs for the selected Media-Store channel. <ol style="list-style-type: none"> <li>1. Click the <b>MediaStore Channel</b> button for the Media-Store channel you want to perform the event on.</li> <li>2. Click the <b>Change Type</b> button and select whether you want to set (<b>Absolute</b>) or reset (<b>Reset</b>) the parameter. Some selections will not be available when you reset the parameter.</li> <li>3. Click the <b>Parameter</b> button and select <b>Cut Frame</b>.</li> <li>4. Enter the frame in the media item that you want to cut to occur for the MediaWipe in the <b>Value</b> field.</li> </ol>
<b>Delete Capture</b>	<b>Switcher &gt; Media-Store &gt; Delete Media Capture</b>	Delete a captured still. <ol style="list-style-type: none"> <li>1. Enter the number of the capture file you want to delete in the <b>Capture File</b> field.</li> </ol>
<b>Media-Store Load</b>	<b>Switcher &gt; Media-Store &gt; Load</b>	Load a media item into the selected Media-Store channel. <ol style="list-style-type: none"> <li>1. Click the <b>MediaStore Channel</b> button for the Media-Store channel you want to perform the event on.</li> <li>2. Click the <b>Location</b> button to select whether the media item you want to load is located on the internal storage (<b>Internal</b>) or on the USB (<b>USB</b>).</li> <li>3. Enter the number of the media item you want to load in the <b>Media Number</b> field.</li> </ol>
<b>Looping</b>	<b>Switcher &gt; Media-Store &gt; Attributes</b>	Select whether an animation will loop at the end for the selected Media-Store channel. <ol style="list-style-type: none"> <li>1. Click the <b>MediaStore Channel</b> button for the Media-Store channel you want to perform the event on.</li> <li>2. Click the <b>Change Type</b> button and select whether you want to set (<b>Absolute</b>) or reset (<b>Reset</b>) the parameter. Some selections will not be available when you reset the parameter.</li> <li>3. Click the <b>Parameter</b> button and select <b>Looping</b>.</li> <li>4. Click the <b>Value</b> button and select whether the animation loops at the end (<b>On</b>) or not (<b>Off</b>).</li> </ol>
<b>Move To Frame</b>	<b>Switcher &gt; Media-Store &gt; Attributes</b>	Move to a specific frame in the media item for the selected Media-Store channel. <ol style="list-style-type: none"> <li>1. Click the <b>MediaStore Channel</b> button for the Media-Store channel you want to perform the event on.</li> <li>2. Click the <b>Change Type</b> button and select whether you want to set (<b>Absolute</b>) or reset (<b>Reset</b>) the parameter. Some selections will not be available when you reset the parameter.</li> <li>3. Click the <b>Parameter</b> button and select <b>Move To Frame</b>.</li> <li>4. Enter the frame that you want to jump to in the media item in the <b>Value</b> field.</li> </ol>

Event	Location	Description
<b>Mute</b>	<b>Switcher &gt; Media-Store &gt; Attributes</b>	Select whether the associated audio is turned on or off during playback for the selected Media-Store channel. <ol style="list-style-type: none"> <li>1. Click the <b>MediaStore Channel</b> button for the Media-Store channel you want to perform the event on.</li> <li>2. Click the <b>Change Type</b> button and select whether you want to set (<b>Absolute</b>) or reset (<b>Reset</b>) the parameter. Some selections will not be available when you reset the parameter.</li> <li>3. Click the <b>Parameter</b> button and select <b>Mute</b>.</li> <li>4. Click the <b>Value</b> button and select whether the audio plays (<b>On</b>) or not (<b>Off</b>).</li> </ol>
<b>Play</b>	<b>Switcher &gt; Media-Store &gt; Channel Action</b>	Start an animation playing for the selected Media-Store channel. <ol style="list-style-type: none"> <li>1. Click the <b>MediaStore Channel</b> button for the Media-Store channel you want to perform the event on.</li> <li>2. Click <b>Toggle Play</b>.</li> </ol>
<b>Play Speed</b>	<b>Switcher &gt; Media-Store &gt; Playback Speed</b>	Select the speed for an animation to play at on the selected Media-Store channel. <ol style="list-style-type: none"> <li>1. Click the <b>MediaStore Channel</b> button for the Media-Store channel you want to perform the event on.</li> <li>2. Click the <b>Change Type</b> button and select whether you want to set (<b>Absolute</b>) or reset (<b>Reset</b>) the parameter. Some selections will not be available when you reset the parameter.</li> <li>3. Click the <b>Parameter</b> button and select <b>Playback Speed</b>.</li> <li>4. Enter the speed, faster or slower than 100%, that you want the animation to play at in the <b>Value (%)</b> field.</li> </ol>
<b>Reset Media</b>	<b>Switcher &gt; Media-Store &gt; Channel Action</b>	Reset the selected Media-Store channel. <ol style="list-style-type: none"> <li>1. Click the <b>MediaStore Channel</b> button for the Media-Store channel you want to perform the event on.</li> <li>2. Click <b>Reset Media</b>.</li> </ol>
<b>Reverse</b>	<b>Switcher &gt; Media-Store &gt; Attributes</b>	Select whether an animation plays in reverse for the selected Media-Store channel. <ol style="list-style-type: none"> <li>1. Click the <b>MediaStore Channel</b> button for the Media-Store channel you want to perform the event on.</li> <li>2. Click the <b>Change Type</b> button and select whether you want to set (<b>Absolute</b>) or reset (<b>Reset</b>) the parameter. Some selections will not be available when you reset the parameter.</li> <li>3. Click the <b>Parameter</b> button and select <b>Reverse</b>.</li> <li>4. Click the <b>Value</b> button and select whether the animation plays in reverse (<b>On</b>) or not (<b>Off</b>).</li> </ol>
<b>Rewind</b>	<b>Switcher &gt; Media-Store &gt; Channel Action</b>	Rewind an animation to the first frame for the selected Media-Store channel. <ol style="list-style-type: none"> <li>1. Click the <b>MediaStore Channel</b> button for the Media-Store channel you want to perform the event on.</li> <li>2. Click <b>Move to Frame 1</b>.</li> </ol>
<b>Shaped</b>	<b>Switcher &gt; Media-Store &gt; Attributes</b>	Select whether the alpha of the media item should be shaped or unshaped for the selected Media-Store channel. <ol style="list-style-type: none"> <li>1. Click the <b>MediaStore Channel</b> button for the Media-Store channel you want to perform the event on.</li> <li>2. Click the <b>Change Type</b> button and select whether you want to set (<b>Absolute</b>) or reset (<b>Reset</b>) the parameter. Some selections will not be available when you reset the parameter.</li> <li>3. Click the <b>Parameter</b> button and select <b>Shaped</b>.</li> <li>4. Click the <b>Value</b> button and select whether the alpha of the media item is shaped (<b>On</b>) or not (<b>Off</b>).</li> </ol>

Event	Location	Description
<b>Thumb Frame</b>	<b>Switcher &gt; Media-Store &gt; Attributes</b>	<p>Select the point, in frames, from the start of the animation that is used as the thumbnail for the media item.</p> <ol style="list-style-type: none"> <li>1. Click the <b>MediaStore Channel</b> button for the Media-Store channel you want to perform the event on.</li> <li>2. Click the <b>Change Type</b> button and select whether you want to set (<b>Absolute</b>) or reset (<b>Reset</b>) the parameter. Some selections will not be available when you reset the parameter.</li> <li>3. Click the <b>Parameter</b> button and select <b>Thumb Frame</b>.</li> <li>4. Enter the frame in the media item that you want to use as the thumbnail.</li> </ol>
<b>Trigger GPI Output</b>	<b>Switcher &gt; Media-Store &gt; Attributes</b>	<p>Select the GPI output that you want to trigger with a MediaWipe for the selected Media-Store channel.</p> <ol style="list-style-type: none"> <li>1. Click the <b>MediaStore Channel</b> button for the Media-Store channel you want to perform the event on.</li> <li>2. Click the <b>Change Type</b> button and select whether you want to set (<b>Absolute</b>) or reset (<b>Reset</b>) the parameter. Some selections will not be available when you reset the parameter.</li> <li>3. Click the <b>Parameter</b> button and select <b>GPO</b>.</li> <li>4. Enter the GPI output that you want to trigger with the MediaWipe in the <b>Value</b> field.</li> </ol>
<b>Trigger GPI Output Delay</b>	<b>Switcher &gt; Media-Store &gt; Attributes</b>	<p>Select the time from the start of the MediaWipe that the GPI output is triggered for the selected Media-Store channel.</p> <ol style="list-style-type: none"> <li>1. Click the <b>MediaStore Channel</b> button for the Media-Store channel you want to perform the event on.</li> <li>2. Click the <b>Change Type</b> button and select whether you want to set (<b>Absolute</b>) or reset (<b>Reset</b>) the parameter. Some selections will not be available when you reset the parameter.</li> <li>3. Click the <b>Parameter</b> button and select <b>GPO Frame</b>.</li> <li>4. Enter the delay, in frames, for the GPI output to be triggered in the <b>Value (fr)</b> field.</li> </ol>
<b>X-Position</b>	<b>Switcher &gt; Media-Store &gt; Attributes</b>	<p>Select the x-axis position for the media item for the selected Media-Store channel.</p> <ol style="list-style-type: none"> <li>1. Click the <b>MediaStore Channel</b> button for the Media-Store channel you want to perform the event on.</li> <li>2. Click the <b>Change Type</b> button and select whether you want to set (<b>Absolute</b>) or reset (<b>Reset</b>) the parameter. Some selections will not be available when you reset the parameter.</li> <li>3. Click the <b>Parameter</b> button and select <b>X-Pos</b>.</li> <li>4. Enter a new position in the <b>Value</b> field.</li> </ol>
<b>Y-Position</b>	<b>Switcher &gt; Media-Store &gt; Attributes</b>	<p>Select the y-axis position for the media item for the selected Media-Store channel.</p> <ol style="list-style-type: none"> <li>1. Click the <b>MediaStore Channel</b> button for the Media-Store channel you want to perform the event on.</li> <li>2. Click the <b>Change Type</b> button and select whether you want to set (<b>Absolute</b>) or reset (<b>Reset</b>) the parameter. Some selections will not be available when you reset the parameter.</li> <li>3. Click the <b>Parameter</b> button and select <b>Y-Pos</b>.</li> <li>4. Enter a new position in the <b>Value</b> field.</li> </ol>

## Matte

Event	Location	Description
Matte Color, Reset	Switcher > Matte > Matte Color Reset	Reset the matte color for the selected ME or aux. <ol style="list-style-type: none"> <li>Click the <b>ME/Matte</b> button for the ME or aux that you want to perform the event on.</li> <li>For an ME, click the <b>Matte</b> button and select <b>Matte</b>.</li> </ol>
Matte Color (HSL)	>Switcher > Matte > Matte Color (HSL)	Select the custom matte color for the selected ME or aux. Each component of the HSL color must be inserted individually. <ol style="list-style-type: none"> <li>Click the <b>ME/Matte</b> button for the ME or aux that you want to perform the event on.</li> <li>Click the <b>Matte</b> button and select <b>Matte</b>.</li> <li>Click the <b>Change Type</b> button and select whether you want to set (<b>Absolute</b>) or reset (<b>Reset</b>) the parameter. Some selections will not be available when you reset the parameter.</li> <li>Click the <b>Component</b> button and select the HSL component you want to assign a value to. A value should be applied to all three components.</li> <li>Enter a value for the selected component in the <b>Value (%)</b> field.</li> </ol>
Matte Color (Preset)	>Switcher > Matte > Matte Color (Preset)	Select a preset matte color for the selected ME or aux. <ol style="list-style-type: none"> <li>Click the <b>Matte</b> button and select <b>Matte</b>.</li> <li>Click the <b>Color</b> button and select the color you want to use.</li> </ol>
Wash Color (HSL)	>Switcher > Matte > Wash Color (HSL)	Select the custom matte color for the selected ME or aux. Each component of the HSL color must be inserted individually. This is the second color of the wash, the first color is set from the matte color. <ol style="list-style-type: none"> <li>Click the <b>ME</b> button for the ME that you want to perform the event on.</li> <li>Click the <b>Matte</b> button and select <b>Wash</b>.</li> <li>Click the <b>Change Type</b> button and select whether you want to set (<b>Absolute</b>) or reset (<b>Reset</b>) the parameter. Some selections will not be available when you reset the parameter.</li> <li>Click the <b>Component</b> button and select the HSL component you want to assign a value to. A value should be applied to all three components.</li> <li>Enter a value for the selected component in the <b>Value (%)</b> field.</li> </ol>
Wash Color (Preset)	>Switcher > Matte > Wash Color (Preset)	Select a preset wash color for the selected ME. This is the second color of the wash, the first color is set from the matte color. <ol style="list-style-type: none"> <li>Click the <b>ME</b> button for the ME that you want to perform the event on.</li> <li>Click the <b>Matte</b> button and select <b>Wash</b>.</li> <li>Click the <b>Color</b> button and select the color you want to use.</li> </ol>
Wash Color Reset	>Switcher > Matte > Wash Color Reset	Reset the matte color for the selected ME. This is the second color of the wash, the first color is set from the matte color. <ol style="list-style-type: none"> <li>Click the <b>ME</b> button for the ME that you want to perform the event on.</li> <li>Click the <b>Matte</b> button and select <b>Wash</b>.</li> </ol>
Wash Generator — Disable	>Switcher > Matte > Wash Enabled Reset	Disable the wash generator for the selected ME. <ol style="list-style-type: none"> <li>Click the <b>ME</b> button for the ME that you want to perform the event on.</li> </ol>
Wash Generator — Enable	>Switcher > Matte > Wash Enabled	Enable the wash generator for the selected ME. <ol style="list-style-type: none"> <li>Click the <b>ME</b> button for the ME that you want to perform the event on.</li> <li>Click the <b>Wash</b> button and select whether the wash generator is enabled (<b>On</b>) or not (<b>Off</b>).</li> </ol>

## Sequencer

Event	Location	Description
<b>Load</b>	<b>Sequencer &gt; Load</b>	Load a sequence into the selected Sequencer. <ol style="list-style-type: none"> <li>1. Click the <b>Sequencer</b> button and select the Sequencer you want to perform the event on.</li> <li>2. Click the <b>Change Type</b> button and select whether you want to set (<b>Absolute</b>) or reset (<b>Reset</b>) the parameter. Some selections will not be available when you reset the parameter.</li> <li>3. In the <b>Value</b> field, enter the sequence number for the sequence you want to load in the selected Sequencer.</li> </ol>
<b>Reload</b>	<b>Sequencer &gt; Reload</b>	Reload the sequence currently loaded into the selected Sequencer. <ol style="list-style-type: none"> <li>1. Click the <b>Sequencer</b> button and select the Sequencer you want to perform the event on.</li> </ol>
<b>Clear</b>	<b>Sequencer &gt; Clear</b>	Unload the sequence currently loaded into the selected Sequencer. <ol style="list-style-type: none"> <li>1. Click the <b>Sequencer</b> button and select the Sequencer you want to perform the event on.</li> </ol>
<b>Next</b>	<b>Sequencer &gt; Next</b>	Run the next event in the selected Sequencer. <ol style="list-style-type: none"> <li>1. Click the <b>Sequencer</b> button and select the Sequencer you want to perform the event on.</li> </ol>
<b>Up</b>	<b>Sequencer &gt; Up</b>	Move the next event highlight (green) up one event in the sequence loaded into the selected Sequencer. <ol style="list-style-type: none"> <li>1. Click the <b>Sequencer</b> button and select the Sequencer you want to perform the event on.</li> </ol>
<b>Down</b>	<b>Sequencer &gt; Down</b>	Move the next event highlight (green) down one event in the sequence loaded into the selected Sequencer. <ol style="list-style-type: none"> <li>1. Click the <b>Sequencer</b> button and select the Sequencer you want to perform the event on.</li> </ol>
<b>Link</b>	<b>Sequencer &gt; Link</b>	Turn Link on or off for the selected Sequencer. <ol style="list-style-type: none"> <li>1. Click the <b>Sequencer</b> button and select the Sequencer you want to perform the event on.</li> <li>2. Click the <b>Change Type</b> button and select whether you want to set (<b>Absolute</b>) or reset (<b>Reset</b>) the parameter. Some selections will not be available when you reset the parameter.</li> <li>3. Click a <b>Value</b> button to turn link <b>On</b> or <b>Off</b>.</li> </ol>

## Special

Event	Location	Description
<b>Row ME Assignment</b>	<b>Special &gt; Row ME Assignment</b>	Assign a control panel row to an ME, MiniME™, or Canvas on a particular panel. <ol style="list-style-type: none"> <li>1. Click the <b>Panel</b> button for the control panel that you want to assign a row from.</li> <li>2. Click the <b>Row</b> button for the row on the control panel that you want to assign to an ME.</li> <li>3. Click the <b>ME</b> button as select the area that you want to assign the control panel row to.</li> </ol>



## Switcher Operation

Event	Location	Description
<b>Bus Source Select</b>	<b>Switcher &gt; Bus Source</b>	<p>Select a source on the selected bus for the selected area.</p> <ol style="list-style-type: none"> <li>1. Click the <b>ME</b> button and select the area that you want to select a bus on.</li> <li>2. Click the <b>Bus/Keyer</b> button and select the bus that you want to select a source on.</li> <li>3. If you selected a key bus, click a <b>Bus</b> button to select whether you are selecting a source for the fill (<b>Video</b>) or the alpha (<b>Alpha</b>) of the key.</li> <li>4. Click the <b>Source</b> button and select the source that you want on the selected bus.</li> </ol>
<b>ME Copy</b>	<b>Switcher &gt; ME Copy</b>	<p>Copy the contents of one area to another.</p> <ol style="list-style-type: none"> <li>1. Click the <b>Target ME</b> button and select the location that you want to copy to.</li> <li>2. Click the <b>Source ME</b> button and select the location that you want to copy from.</li> </ol>
<b>Memory Recall</b>	<b>Switcher &gt; Memory Recall</b>	<p>Recall a memory for the selected area.</p> <ol style="list-style-type: none"> <li>1. Click the <b>Include</b> button and select all the locations that you want to perform the memory recall on.</li> <li>2. Click the <b>Bank</b> button and select the bank that you want to recall the memory on.</li> <li>3. Click the <b>Memory</b> button and select the memory that you want to recall.</li> </ol>
<b>RState, Load</b>	<b>Switcher &gt; Load RState</b>	<p>Load the custom reset settings for the selected area.</p> <ol style="list-style-type: none"> <li>1. Click the <b>Include</b> button and select all the locations that you want to recall the custom reset settings on.</li> </ol>
<b>Memory Recall</b>	<b>Switcher &gt; Memory Recall</b>	<p>Recall a memory for the selected area.</p> <ol style="list-style-type: none"> <li>1. Click the <b>Include</b> button and select all the locations that you want to perform the memory recall on.</li> <li>2. Click the <b>Bank</b> button and select the bank that you want to recall the memory on.</li> <li>3. Click the <b>Memory</b> button and select the memory that you want to recall.</li> </ol>

## Transitions

Event	Location	Description
<b>Combined Transition Event</b>		
<b>Transition Action - Dissolve</b>	<b>Switcher &gt; Transition &gt; Transition Action</b>	<p>Set up a dissolve transition with a single custom control event.</p> <ol style="list-style-type: none"> <li>1. Click the <b>ME</b> button and select the area that you want to perform the event on.</li> <li>2. Click <b>Dissolve</b>.</li> <li>3. Click the <b>Toggle, Include On, and Include Off</b> buttons to set up what is included with the next transition. Something must always be selected for the toggle inclusion. Key toggle and on/off inclusions are mutually exclusive. <ul style="list-style-type: none"> <li>• <b>Toggle</b> — select the background and any keys that you want included with the transition. This is the same as using the next trans buttons on the Transition area of a control panel.</li> <li>• <b>Include On</b> — select that keys that you want to transition on-air with the next transition. If a key is already on-air it is ignored.</li> <li>• <b>Include Off</b> — select that keys that you want to transition off-air with the next transition. If a key is already off-air it is ignored.</li> </ul> </li> <li>4. Click an <b>Auto Trans</b> button to select whether the transition is performed with the custom control (<b>On</b>) or if the custom control only sets up the next transition but does not perform it (<b>Off</b>).</li> <li>5. Enter a rate for transition in the <b>Trans Rate (fr)</b> field. A rate of 0 is performed as a cut.</li> <li>6. Click a <b>Diss/Flash</b> button to select whether the transition is performed as a dissolve (<b>Dissolve</b>) or a WhiteFlash (<b>Flash</b>). The existing onset, offset, and color values for the ME are used for the WhiteFlash.</li> </ol>
<b>Transition Action - Wipe</b>	<b>Switcher &gt; Transition &gt; Transition Action</b>	<p>Set up a wipe transition with a single custom control event.</p> <ol style="list-style-type: none"> <li>1. Click the <b>ME</b> button and select the area that you want to perform the event on.</li> <li>2. Click <b>Wipe</b>.</li> <li>3. Click the <b>Toggle, Include On, and Include Off</b> buttons to set up what is included with the next transition. Something must always be selected for the toggle inclusion. Key toggle and on/off inclusions are mutually exclusive. <ul style="list-style-type: none"> <li>• <b>Toggle</b> — select the background and any keys that you want included with the transition. This is the same as using the next trans buttons on the Transition area of a control panel.</li> <li>• <b>Include On</b> — select that keys that you want to transition on-air with the next transition. If a key is already on-air it is ignored.</li> <li>• <b>Include Off</b> — select that keys that you want to transition off-air with the next transition. If a key is already off-air it is ignored.</li> </ul> </li> <li>4. Click an <b>Auto Trans</b> button to select whether the transition is performed with the custom control (<b>On</b>) or if the custom control only sets up the next transition but does not perform it (<b>Off</b>).</li> <li>5. Enter a rate for transition in the <b>Trans Rate (fr)</b> field. A rate of 0 is performed as a cut.</li> <li>6. Click the <b>Pattern</b> button and select the wipe pattern you want to use for the transition.</li> </ol>

Event	Location	Description
Transition Action - DVE	Switcher > Transition > Transition Action	<p>Set up a DVE wipe transition with a single custom control event.</p> <ol style="list-style-type: none"> <li>1. Click the <b>ME</b> button and select the area that you want to perform the event on.</li> <li>2. Click <b>DVE</b>.</li> <li>3. Click the <b>Toggle, Include On, and Include Off</b> buttons to set up what is included with the next transition. Something must always be selected for the toggle inclusion. Key toggle and on/off inclusions are mutually exclusive. <ul style="list-style-type: none"> <li>• <b>Toggle</b> — select the background and any keys that you want included with the transition. This is the same as using the next trans buttons on the Transition area of a control panel.</li> <li>• <b>Include On</b> — select that keys that you want to transition on-air with the next transition. If a key is already on-air it is ignored.</li> <li>• <b>Include Off</b> — select that keys that you want to transition off-air with the next transition. If a key is already off-air it is ignored.</li> </ul> </li> <li>4. Click an <b>Auto Trans</b> button to select whether the transition is performed with the custom control (<b>On</b>) or if the custom control only sets up the next transition but does not perform it (<b>Off</b>).</li> <li>5. Enter a rate for transition in the <b>Trans Rate (fr)</b> field. A rate of 0 is performed as a cut.</li> <li>6. Click the <b>DVE Effect</b> button and select the DVE wipe pattern you want to use for the transition.</li> </ol>
Transition Action - MediaWipe	Switcher > Transition > Transition Action	<p>Set up a MediaWipe transition with a single custom control event.</p> <ol style="list-style-type: none"> <li>1. Click the <b>ME</b> button and select the area that you want to perform the event on.</li> <li>2. Click <b>MediaWipe</b>.</li> <li>3. Click the <b>Toggle, Include On, and Include Off</b> buttons to set up what is included with the next transition. Something must always be selected for the toggle inclusion. Key toggle and on/off inclusions are mutually exclusive. <ul style="list-style-type: none"> <li>• <b>Toggle</b> — select the background and any keys that you want included with the transition. This is the same as using the next trans buttons on the Transition area of a control panel.</li> <li>• <b>Include On</b> — select that keys that you want to transition on-air with the next transition. If a key is already on-air it is ignored.</li> <li>• <b>Include Off</b> — select that keys that you want to transition off-air with the next transition. If a key is already off-air it is ignored.</li> </ul> </li> <li>4. Click an <b>Auto Trans</b> button to select whether the transition is performed with the custom control (<b>On</b>) or if the custom control only sets up the next transition but does not perform it (<b>Off</b>).</li> <li>5. Click the <b>Layer</b> button to select what the MediaWipe animation covers.</li> <li>6. Click a <b>Location</b> button for the drive that the animation to use for the MediaWipe is stored on.</li> <li>7. Enter the media number for the animation you want use for the MediaWipe in the <b>Media Number</b> field.</li> <li>8. Click a <b>Channel</b> number to select the Media-Store channel you want to use for the MediaWipe.</li> </ol>
<b>Individual Transition Events</b>		
Auto Trans	Switcher > Transition > ME Trans Action	<p>Performs an auto transition on the selected area.</p> <ol style="list-style-type: none"> <li>1. Click the <b>ME</b> button and select the area that you want to perform the event on.</li> <li>2. Click the <b>Action</b> button and select <b>Auto Trans</b>.</li> </ol>

Event	Location	Description
<b>Cut</b>	<b>Switcher &gt; Transition &gt; ME Trans Action</b>	Performs a cut on the selected ME. <ol style="list-style-type: none"> <li>1. Click the <b>ME</b> button and select the area that you want to perform the event on.</li> <li>2. Click the <b>Action</b> button and select <b>Cut</b>.</li> </ol>
<b>DVE Wipe, Reset</b>	<b>Switcher &gt; Transition &gt; DVE Wipe Reset</b>	Reset the parameters or direction and flip-flop for the DVE wipe transition of the selected ME. <ol style="list-style-type: none"> <li>1. Click the <b>ME</b> button for the ME that you want to perform the event on.</li> <li>2. Click <b>Reset</b> to reset the DVE wipe parameters.</li> </ol>
<b>DVE Wipe Direction (Flip-Flop)</b>	<b>Switcher &gt; Transition &gt; DVE Wipe Direction</b>	Select whether the DVE wipe reverses direction for every second transition of the selected ME. <ol style="list-style-type: none"> <li>1. Click the <b>ME</b> button for the ME that you want to perform the event on.</li> <li>2. Click the <b>Change Type</b> button and select whether you want to set <b>(Absolute)</b> or reset <b>(Reset)</b> the parameter. Some selections will not be available when you reset the parameter.</li> <li>3. Click <b>Flip-Flip</b>.</li> <li>4. Click <b>On</b> or <b>Off</b> to select whether Flip-Flop is on <b>(On)</b> or not <b>(Off)</b>.</li> </ol>
<b>DVE Wipe Direction</b>	<b>Switcher &gt; Transition &gt; DVE Wipe Direction</b>	Select the direction for the DVE wipe transition of the selected ME. <ol style="list-style-type: none"> <li>1. Click the <b>ME</b> button for the ME that you want to perform the event on.</li> <li>2. Click the <b>Change Type</b> button and select whether you want to set <b>(Absolute)</b> or reset <b>(Reset)</b> the parameter. Some selections will not be available when you reset the parameter.</li> <li>3. Click <b>Direction</b>.</li> <li>4. Click <b>Forward</b> or <b>Reverse</b> to select whether the DVE wipe moves in a forward <b>(Forward)</b> or reverse <b>(Reverse)</b> direction.</li> </ol>
<b>DVE Wipe Pattern</b>	<b>Switcher &gt; Transition &gt; DVE Wipe Effect</b>	Select the pattern you want to use for a DVE wipe transition of the selected ME. <ol style="list-style-type: none"> <li>1. Click the <b>ME</b> button for the ME that you want to perform the event on.</li> <li>2. Click the <b>Effect</b> button and select the pattern you want to use for the DVE wipe.</li> </ol>
<b>MediaWipe — Channel</b>	<b>Switcher &gt; Transition &gt; Media Wipe Channel</b>	Select which Media-Store channel will be used for the MediaWipe transition of the selected ME. <ol style="list-style-type: none"> <li>1. Click the <b>ME</b> button for the ME that you want to perform the event on.</li> <li>2. Click <b>M1</b> or <b>M2</b> to assign that Media-Store channel to the MediaWipe.</li> </ol>
<b>MediaWipe Cut Point, Set</b>	<b>Switcher &gt; Transition &gt; ME Trans Action</b>	Sets the cut point for a MediaWipe transition for the selected area. You must select the point in the transition that you want to place the cut before running this event. <ol style="list-style-type: none"> <li>1. Click the <b>ME</b> button and select the area that you want to perform the event on.</li> <li>2. Click the <b>Action</b> button and select <b>Set Media Cut</b>.</li> </ol>
<b>MediaWipe — Direction, Flip-Flop</b>	<b>Switcher &gt; Transition &gt; DVE Wipe Direction</b>	Select whether the MediaWipe reverses direction for every second transition of the selected ME. <ol style="list-style-type: none"> <li>1. Click the <b>ME</b> button for the ME that you want to perform the event on.</li> <li>2. Click the <b>Change Type</b> button and select whether you want to set <b>(Absolute)</b> or reset <b>(Reset)</b> the parameter. Some selections will not be available when you reset the parameter.</li> <li>3. Click <b>Flip-Flip</b>.</li> <li>4. Click the <b>Value</b> button and select whether Flip-Flop is on <b>(On)</b> or not <b>(Off)</b>.</li> </ol>

Event	Location	Description
MediaWipe — Direction	Switcher > Transition > DVE Wipe Direction	Select the direction for the MediaWipe transition of the selected ME. <ol style="list-style-type: none"> <li>1. Click the <b>ME</b> button for the ME that you want to perform the event on.</li> <li>2. Click the <b>Change Type</b> button and select whether you want to set (<b>Absolute</b>) or reset (<b>Reset</b>) the parameter. Some selections will not be available when you reset the parameter.</li> <li>3. Click <b>Direction</b>.</li> <li>4. Click the <b>Value</b> button and select whether the MediaWipe moves in a forward (<b>Forward</b>) or reverse (<b>Reverse</b>) direction.</li> </ol>
MediaWipe — Layer	Switcher > Transition > ME Media Trans Layer	Select which Media-Store channel will be used for the MediaWipe transition of the selected ME. <ol style="list-style-type: none"> <li>1. Click the <b>ME</b> button for the ME that you want to perform the event on.</li> <li>2. Click the <b>Layer</b> button to select what the MediaWipe animation covers.</li> </ol>
MediaWipe Trans End Point, Set	Switcher > Transition > ME Trans Action	Sets the ending point for a MediaWipe transition for the selected area. Use the fader to move through the animation to the point you want to end the transition and run this CC to save that point. <ol style="list-style-type: none"> <li>1. Click the <b>ME</b> button and select the area that you want to perform the event on.</li> <li>2. Click the <b>Action</b> button and select <b>Set Media Trans End</b>.</li> </ol>
MediaWipe Trans Start Point, Set	Switcher > Transition > ME Trans Action	Sets the starting point for a MediaWipe transition for the selected area. Use the fader to move through the animation to the point you want to start the transition and run this CC to save that point. <ol style="list-style-type: none"> <li>1. Click the <b>ME</b> button and select the area that you want to perform the event on.</li> <li>2. Click the <b>Action</b> button and select <b>Set Media Trans Start</b>.</li> </ol>
MediaWipe Trans Thumbnail	Switcher > Transition > ME Trans Action	Sets the starting point for a MediaWipe transition for the selected area. <ol style="list-style-type: none"> <li>1. Click the <b>ME</b> button and select the area that you want to perform the event on.</li> <li>2. Click the <b>Action</b> button and select <b>Set Media Thumb</b>.</li> </ol>
ME Dissolve Type	Switcher > Transition > ME Dissolve Type	Select the type of dissolve transition (WhiteFlash or Dissolve) you want to use. <ol style="list-style-type: none"> <li>1. Click the <b>ME</b> button and select the area that you want to perform the event on.</li> <li>2. Click a <b>Type</b> button to select a Dissolve (<b>Dissolve</b>) or WhiteFlash (<b>Flash</b>) transition.</li> </ol>
ME Trans Rate	Switcher > Transition > ME Trans Parameter	Set or reset the background transition rate of the selected area. <ol style="list-style-type: none"> <li>1. Click the <b>ME</b> button and select the area that you want to perform the event on.</li> <li>2. Click the <b>Parameter</b> button and select <b>ME Trans Rate</b>.</li> <li>3. Click the <b>Change Type</b> button and select whether you want to set (<b>Absolute</b>) or reset (<b>Reset</b>) the parameter. Some selections will not be available when you reset the parameter.</li> <li>4. Enter a new transition rate, in frames, in the <b>Value (fr)</b> field.</li> </ol>
ME Trans Type	Switcher > Transition > ME Trans Type	Select the transition type for a background transition of the selected area. <ol style="list-style-type: none"> <li>1. Click the <b>ME</b> button and select the area that you want to perform the event on.</li> <li>2. Click the <b>Type</b> button for the type of transition you want to use.</li> </ol>
ME WhiteFlash Color	Switcher > Transition > ME Flash Dissolve Color (Preset)	Select color for the WhiteFlash transition. <ol style="list-style-type: none"> <li>1. Click the <b>ME</b> button and select the area that you want to perform the event on.</li> <li>2. Click the <b>Color</b> button and select the preset color you want to use.</li> </ol>

Event	Location	Description
<b>ME WhiteFlash Offset</b>	<b>Switcher &gt; Transition &gt; ME Trans Value</b>	Select time for the offset of the WhiteFlash transition. <ol style="list-style-type: none"> <li>1. Click the <b>ME</b> button and select the area that you want to perform the event on.</li> <li>2. Click <b>Flash Offset</b>.</li> <li>3. Click the <b>Change Type</b> button and select whether you want to set (<b>Absolute</b>) or reset (<b>Reset</b>) the parameter. Some selections will not be available when you reset the parameter.</li> <li>4. Enter a new offset position in the <b>Value (%)</b> field.</li> </ol>
<b>ME WhiteFlash Onset</b>	<b>Switcher &gt; Transition &gt; ME Trans Value</b>	Select time for the onset of the WhiteFlash transition. <ol style="list-style-type: none"> <li>1. Click the <b>ME</b> button and select the area that you want to perform the event on.</li> <li>2. Click <b>Flash Onset</b>.</li> <li>3. Click the <b>Change Type</b> button and select whether you want to set (<b>Absolute</b>) or reset (<b>Reset</b>) the parameter. Some selections will not be available when you reset the parameter.</li> <li>4. Enter a new onset position in the <b>Value (%)</b> field.</li> </ol>
<b>Reset</b>	<b>Switcher &gt; Transition &gt; ME Trans Action</b>	Resets the transition area of the selected area. <ol style="list-style-type: none"> <li>1. Click the <b>ME</b> button and select the area that you want to perform the event on.</li> <li>2. Click the <b>Action</b> button and select <b>Reset</b>.</li> </ol>
<b>Roll Clip</b>	<b>Switcher &gt; Transition &gt; Roll Clip</b>	Turn the Roll Clip feature on or off for the selected area. <ol style="list-style-type: none"> <li>1. Click the <b>ME</b> button and select the area that you want to perform the event on.</li> <li>2. Click the <b>Value</b> button and select whether roll clip is on (<b>On</b>) or not (<b>Off</b>).</li> </ol>
<b>Trans Clear</b>	<b>Switcher &gt; Transition &gt; ME Trans Action</b>	Configures the next transition area of the selected area to take all keys off-air with the next transition. <ol style="list-style-type: none"> <li>1. Click the <b>ME</b> button and select the area that you want to perform the event on.</li> <li>2. Click the <b>Action</b> button and select <b>Trans Clear</b>.</li> </ol>
<b>Trans Delay</b>	<b>Switcher &gt; Transition &gt; ME Trans Action</b>	Applies the pre-delay to the transition. <ol style="list-style-type: none"> <li>1. Click the <b>ME</b> button and select the area that you want to perform the event on.</li> <li>2. Click the <b>Action</b> button and select <b>Delayed Auto Trans</b>.</li> </ol>
<b>Trans Elements</b>	<b>Switcher &gt; Transition &gt; ME Trans Element</b>	Select the elements to be included in the next transition of the selected area. <ol style="list-style-type: none"> <li>1. Click the <b>ME</b> button and select the area that you want to perform the event on.</li> <li>2. Click the <b>Elements</b> button and select background and/or the keys that you want to include in the next transition.</li> </ol>
<b>Trans Limit — On/Off</b>	<b>Switcher &gt; Transition &gt; ME Trans Limit</b>	Turn the transition limit feature on or off for the selected area. <ol style="list-style-type: none"> <li>1. Click the <b>ME</b> button and select the area that you want to perform the event on.</li> <li>2. Click the <b>Change Type</b> button and select whether you want to set (<b>Absolute</b>) or reset (<b>Reset</b>) the parameter. Some selections will not be available when you reset the parameter.</li> <li>3. Click the <b>Value</b> button and select whether trans limit is on (<b>On</b>) or not (<b>Off</b>).</li> </ol>
<b>Trans Limit — Reset</b>	<b>Switcher &gt; Transition &gt; ME Trans Action</b>	Resets the transition limit point of the selected area. <ol style="list-style-type: none"> <li>1. Click the <b>ME</b> button and select the area that you want to perform the event on.</li> <li>2. Click the <b>Action</b> button and select <b>Reset Limit</b>.</li> </ol>

Event	Location	Description
Trans Limit — Set	Switcher > Transition > ME Trans Action	<p>Sets the transition limit point of the selected area. You must select the point in the transition that you want to place the limit before running this event.</p> <ol style="list-style-type: none"> <li>1. Click the <b>ME</b> button and select the area that you want to perform the event on.</li> <li>2. Click the <b>Action</b> button and select <b>Set Limit</b>.</li> </ol>
Trans Limit — Value	Switcher > Transition > ME Trans Value	<p>Select the limit point for the trans limit of the selected area.</p> <ol style="list-style-type: none"> <li>1. Click the <b>ME</b> button and select the area that you want to perform the event on.</li> <li>2. Click <b>Trans Limit</b>.</li> <li>3. Click the <b>Change Type</b> button and select whether you want to set (<b>Absolute</b>) or reset (<b>Reset</b>) the parameter. Some selections will not be available when you reset the parameter.</li> <li>4. Enter the point in the transition that you want to place the trans limit in the <b>Value (%)</b> field.</li> </ol>
Wipe Direction (Flip-Flop)	Switcher > Transition > Wipe Direction	<p>Select whether the wipe reverses direction for every second transition of the selected ME.</p> <ol style="list-style-type: none"> <li>1. Click the <b>ME</b> button for the ME that you want to perform the event on.</li> <li>2. Click the <b>Pattern</b> button and select <b>Wipe</b>.</li> <li>3. Click the <b>Change Type</b> button and select whether you want to set (<b>Absolute</b>) or reset (<b>Reset</b>) the parameter. Some selections will not be available when you reset the parameter.</li> <li>4. Click the <b>Parameter</b> button and select <b>Flip-Flop</b>.</li> <li>5. Click the <b>Value</b> button and select whether Flip-Flop is on (<b>On</b>) or off (<b>Off</b>).</li> </ol>
Wipe Direction	Switcher > Transition > Wipe Direction	<p>Select the direction for the wipe transition of the selected ME.</p> <ol style="list-style-type: none"> <li>1. Click the <b>ME</b> button for the ME that you want to perform the event on.</li> <li>2. Click the <b>Pattern</b> button and select <b>Wipe</b>.</li> <li>3. Click the <b>Change Type</b> button and select whether you want to set (<b>Absolute</b>) or reset (<b>Reset</b>) the parameter. Some selections will not be available when you reset the parameter.</li> <li>4. Click the <b>Parameter</b> button and select <b>Direction</b>.</li> <li>5. Click the <b>Value</b> button and select whether the wipe moves in a forward (<b>Forward</b>) or reverse (<b>Reverse</b>) direction.</li> </ol>
Wipe Pattern — Aspect Ratio	Switcher > Transition > Wipe Param	<p>Select the aspect ratio for the wipe pattern you want to use for a wipe transition of the selected ME.</p> <ol style="list-style-type: none"> <li>1. Click the <b>ME</b> button for the ME that you want to perform the event on.</li> <li>2. Click the <b>Parameter</b> button and select <b>Aspect</b>.</li> <li>3. Click the <b>Change Type</b> button and select whether you want to set (<b>Absolute</b>) or reset (<b>Reset</b>) the parameter. Some selections will not be available when you reset the parameter.</li> <li>4. Enter an aspect ratio in the <b>Value (%)</b> field.</li> </ol>
Wipe Pattern — Border Color (HSL)	Switcher > Transition > Wipe Border Color (HSL)	<p>Select the custom color you want to apply to the border of the pattern for the wipe transition of the selected ME. Each component of the HSL color must be inserted individually.</p> <ol style="list-style-type: none"> <li>1. Click the <b>ME</b> button for the ME that you want to perform the event on.</li> <li>2. Click the <b>Matte</b> button and select <b>Wipe Border</b>.</li> <li>3. Click the <b>Change Type</b> button and select whether you want to set (<b>Absolute</b>) or reset (<b>Reset</b>) the parameter. Some selections will not be available when you reset the parameter.</li> <li>4. Click the <b>Component</b> button and select the HSL component you want to assign a value to. A value should be applied to all three components.</li> <li>5. Enter a value for the selected component in the <b>Value (%)</b> field.</li> </ol>

Event	Location	Description
<b>Wipe Pattern — Border Color (Preset)</b>	<b>Switcher &gt; Transition &gt; Wipe Border Color (Preset)</b>	Select the preset color you want to apply to the border of the pattern for the wipe transition of the selected ME. <ol style="list-style-type: none"> <li>1. Click the <b>ME</b> button for the ME that you want to perform the event on.</li> <li>2. Click the <b>Matte</b> button and select <b>Wipe Border</b>.</li> <li>3. Click the <b>Color</b> button and select the preset color you want to apply to the border.</li> </ol>
<b>Wipe Pattern — Border Size</b>	<b>Switcher &gt; Transition &gt; Wipe Param</b>	Select the size of border for the wipe pattern you want to use for a wipe transition of the selected ME. <ol style="list-style-type: none"> <li>1. Click the <b>ME</b> button for the ME that you want to perform the event on.</li> <li>2. Click the <b>Parameter</b> button and select <b>Border Size</b>.</li> <li>3. Click the <b>Change Type</b> button and select whether you want to set <b>(Absolute)</b> or reset <b>(Reset)</b> the parameter. Some selections will not be available when you reset the parameter.</li> <li>4. Enter a size for the border in the <b>Value (%)</b> field.</li> </ol>
<b>Wipe Pattern — Edge Softness</b>	<b>Switcher &gt; Transition &gt; Wipe Param</b>	Select the amount of softness to apply to the edge of the pattern or border for the wipe pattern you want to use for a wipe transition of the selected ME. <ol style="list-style-type: none"> <li>1. Click the <b>ME</b> button for the ME that you want to perform the event on.</li> <li>2. Click the <b>Parameter</b> button and select <b>Softness</b>.</li> <li>3. Click the <b>Change Type</b> button and select whether you want to set <b>(Absolute)</b> or reset <b>(Reset)</b> the parameter. Some selections will not be available when you reset the parameter.</li> <li>4. Enter an amount of softness for the pattern or border in the <b>Value (%)</b> field.</li> </ol>
<b>Wipe Pattern — Horizontal Multiplication</b>	<b>Switcher &gt; Transition &gt; Wipe Param</b>	Select the number of times you want to multiply the wipe pattern horizontally for the wipe transition of the selected ME. <ol style="list-style-type: none"> <li>1. Click the <b>ME</b> button for the ME that you want to perform the event on.</li> <li>2. Click the <b>Parameter</b> button and select <b>Horizontal Mult</b>.</li> <li>3. Click the <b>Change Type</b> button and select whether you want to set <b>(Absolute)</b> or reset <b>(Reset)</b> the parameter. Some selections will not be available when you reset the parameter.</li> <li>4. Enter the number of times the pattern is multiplied in the <b>Value</b> field.</li> </ol>
<b>Wipe Pattern — Pattern</b>	<b>Switcher &gt; Transition &gt; Wipe Effect</b>	Select the pattern you want to use for a wipe transition of the selected ME. <ol style="list-style-type: none"> <li>1. Click the <b>ME</b> button for the ME that you want to perform the event on.</li> <li>2. Click the <b>Pattern</b> button and select the pattern you want to use for the wipe.</li> </ol>
<b>Wipe Pattern — Rotation</b>	<b>Switcher &gt; Transition &gt; Wipe Param</b>	Select the rotation for the wipe pattern you want to use for a wipe transition of the selected ME. <ol style="list-style-type: none"> <li>1. Click the <b>ME</b> button for the ME that you want to perform the event on.</li> <li>2. Click the <b>Parameter</b> button and select <b>Rotation</b>.</li> <li>3. Click the <b>Change Type</b> button and select whether you want to set <b>(Absolute)</b> or reset <b>(Reset)</b> the parameter. Some selections will not be available when you reset the parameter.</li> <li>4. Enter a rotation in the <b>Value (%)</b> field.</li> </ol>
<b>Wipe Pattern — Size</b>	<b>Switcher &gt; Transition &gt; Wipe Param</b>	Select the size for the wipe pattern you want to use for a wipe transition of the selected ME. <ol style="list-style-type: none"> <li>1. Click the <b>ME</b> button for the ME that you want to perform the event on.</li> <li>2. Click the <b>Parameter</b> button and select <b>Size</b>.</li> <li>3. Click the <b>Change Type</b> button and select whether you want to set <b>(Absolute)</b> or reset <b>(Reset)</b> the parameter. Some selections will not be available when you reset the parameter.</li> <li>4. Enter a new size in the <b>Value (%)</b> field.</li> </ol>



Event	Location	Description
<b>Wipe Pattern — Vertical Multiplication</b>	<b>Switcher &gt; Transition &gt; Wipe Param</b>	Select the number of times you want to multiply the wipe pattern vertically for the wipe transition of the selected ME. <ol style="list-style-type: none"> <li>1. Click the <b>ME</b> button for the ME that you want to perform the event on.</li> <li>2. Click the <b>Parameter</b> button and select <b>Vertical Mult</b>.</li> <li>3. Click the <b>Change Type</b> button and select whether you want to set (<b>Absolute</b>) or reset (<b>Reset</b>) the parameter. Some selections will not be available when you reset the parameter.</li> <li>4. Enter the number of times the pattern is multiplied in the <b>Value</b> field.</li> </ol>
<b>Wipe Pattern — X-Position</b>	<b>Switcher &gt; Transition &gt; Wipe Param</b>	Select the x-axis position for the wipe pattern you want to use for a wipe transition of the selected ME. <ol style="list-style-type: none"> <li>1. Click the <b>ME</b> button for the ME that you want to perform the event on.</li> <li>2. Click the <b>Parameter</b> button and select <b>X-Pos</b>.</li> <li>3. Click the <b>Change Type</b> button and select whether you want to set (<b>Absolute</b>) or reset (<b>Reset</b>) the parameter. Some selections will not be available when you reset the parameter.</li> <li>4. Enter a new position in the <b>Value (%)</b> field.</li> </ol>
<b>Wipe Pattern — Y-Position</b>	<b>Switcher &gt; Transition &gt; Wipe Param</b>	Select the y-axis position for the wipe pattern you want to use for a wipe transition of the selected ME. <ol style="list-style-type: none"> <li>1. Click the <b>ME</b> button for the ME that you want to perform the event on.</li> <li>2. Click the <b>Parameter</b> button and select <b>Y-Pos</b>.</li> <li>3. Click the <b>Change Type</b> button and select whether you want to set (<b>Absolute</b>) or reset (<b>Reset</b>) the parameter. Some selections will not be available when you reset the parameter.</li> <li>4. Enter a new position in the <b>Value (%)</b> field.</li> </ol>
<b>Wipe Reset</b>	<b>Switcher &gt; Transition &gt; Wipe Reset</b>	Reset the parameters or direction and flip-flop for the wipe transition of the selected ME. <ol style="list-style-type: none"> <li>1. Click the <b>ME</b> button for the ME that you want to perform the event on.</li> <li>2. Click <b>Reset Params</b> to reset the wipe parameters or <b>Reset Direction</b> to reset the wipe direction and flip-flop.</li> </ol>

## UltraScene

Event	Location	Description
<b>Recall UltraScene</b>	<b>UltraScene &gt; UltraScene Recall/Store</b>	Recall an UltraScene memory. <ol style="list-style-type: none"> <li>1. Click the <b>UltraScene</b> button and select the UltraScene memory you want to recall</li> <li>2. Click <b>Recall Memory</b>.</li> </ol>
<b>Store UltraScene</b>	<b>UltraScene &gt; UltraScene Recall/Store</b>	Store an UltraScene memory. <ol style="list-style-type: none"> <li>1. Click the <b>UltraScene</b> button and select the UltraScene memory location you want to store to.</li> <li>2. Click <b>Store Memory</b>.</li> </ol>

## Personality Custom Controls

### Personality

Event	Location	Description
Personality — Auto Remove Key	Switcher Personality > Auto Remove Key	<p>Have a key removed from the Next Transition area, so that it is not included in the next transition, after it has been transitioned off-air using the <b>KEY X CUT</b> or <b>KEY X AUTO</b> buttons.</p> <ol style="list-style-type: none"> <li>1. Click the <b>Change Type</b> button and select whether you want to set (<b>Absolute</b>) or reset (<b>Reset</b>) the parameter. Some selections will not be available when you reset the parameter.</li> <li>2. Click the <b>Value</b> button and select whether the personality option is on (<b>On</b>) or not (<b>Off</b>).</li> </ol>
Personality — Auto Trans Second Press (Key)	Switcher Personality > Key Auto Trans 2nd Press	<p>Select how the switcher reacts when the <b>KEY AUTO</b> button is pressed during a transition.</p> <ol style="list-style-type: none"> <li>1. Click the <b>Second Auto</b> button and select how the switcher reacts to pressing the button during a transition. <ul style="list-style-type: none"> <li>• <b>Ignore</b> — the buttons are ignored during the transition</li> <li>• <b>Halt Forward</b> — halt the transition and move forward through the transition when pressed again</li> <li>• <b>Halt Reverse</b> — halt the transition and move backwards through the transition when pressed again</li> <li>• <b>Reverse</b> — reverse the transition immediately</li> <li>• <b>Cut</b> — cut the transition to the end</li> </ul> </li> </ol>
Personality — Auto Trans Second Press (ME)	Switcher Personality > ME Auto Trans 2nd Press	<p>Select how the switcher reacts when the <b>AUTO TRANS</b> button is pressed during a transition.</p> <ol style="list-style-type: none"> <li>1. Click the <b>Second Auto</b> button and select how the switcher reacts to pressing the button during a transition. <ul style="list-style-type: none"> <li>• <b>Ignore</b> — the buttons are ignored during the transition</li> <li>• <b>Halt Forward</b> — halt the transition and move forward through the transition when pressed again</li> <li>• <b>Halt Reverse</b> — halt the transition and move backwards through the transition when pressed again</li> <li>• <b>Reverse</b> — reverse the transition immediately</li> <li>• <b>Cut</b> — cut the transition to the end</li> </ul> </li> </ol>
Personality — Next Trans Reset	Switcher Personality > Auto Reset Trans	<p>Have the transition area reset to a default background dissolve after each transition.</p> <ol style="list-style-type: none"> <li>1. Click the <b>Change Type</b> button and select whether you want to set (<b>Absolute</b>) or reset (<b>Reset</b>) the parameter. Some selections will not be available when you reset the parameter.</li> <li>2. Click the <b>Value</b> button and select whether the personality option is on (<b>On</b>) or not (<b>Off</b>).</li> </ol>
Personality — Roll Clip	Switcher Personality > Roll Clip Force	<p>Select whether the Roll Clip functionality is always on.</p> <ol style="list-style-type: none"> <li>1. Click the <b>ME</b> button and select the area that you want to adjust the roll clip for.</li> <li>2. Click a <b>Roll Clip</b> button to select whether Roll Clip is always on (<b>Force</b>) or must be turned on manually (<b>User</b>).</li> </ol>

## Installation Custom Controls

### Switcher Installation

Event	Location	Description
<b>AES Output</b>	<b>Switcher Installation &gt; Output &gt; AES</b>	Assign an audio stream to an AES output. <ol style="list-style-type: none"> <li>1. Click the <b>AES</b> button for the AES output you want to assign an audio stream to.</li> <li>2. Click the <b>Value</b> button and select the audio stream you want to assign to the AES output.</li> </ol>
<b>Ancillary Data Mode</b>	<b>Switcher Installation &gt; Ancillary Mode</b>	Select how the switcher will strip or pass ancillary data. <ol style="list-style-type: none"> <li>1. Click a <b>Value</b> button to select whether ancillary data is stripped (<b>Strip</b>), or passed (<b>Pass</b>).</li> </ol>
<b>Clean Feed</b>	<b>Switcher Installation &gt; ME &gt; ME Clean Feed</b>	Select the clean feed location for the selected ME. <ol style="list-style-type: none"> <li>1. Click the <b>ME</b> button for the ME that you want to perform the event on.</li> <li>2. Click the <b>Before Keyer</b> button and select the key you want the clean feed output to be taken before.</li> </ol>
<b>Color Corrector Color Reset</b>	<b>Switcher Installation &gt; Proc Amp/Color Corrector &gt; Color Corrector R/G/B Reset</b>	Reset the values for the selected color corrector color channel(s). <ol style="list-style-type: none"> <li>1. Click the <b>Input/Output</b> button and select the input or output BNC that has the color corrector assigned to it that you want to reset.</li> <li>2. Click the <b>Color</b> button and select the individual color component (<b>Red, Green, Blue</b>) you want to adjust, or <b>RGB</b> for all of them.</li> </ol>
<b>Color Corrector Enable</b>	<b>Switcher Installation &gt; Proc Amp/Color Corrector &gt; Color Corrector Enable</b>	Enable a Color Corrector for a video input or output. <ol style="list-style-type: none"> <li>1. Click the <b>Input/Output</b> button and select the input or output BNC that you want assign a Color Corrector to.</li> <li>2. Click the <b>Change Type</b> button and select whether you want to set (<b>Absolute</b>) or reset (<b>Reset</b>) the parameter. Some selections will not be available when you reset the parameter.</li> <li>3. Click a <b>Value</b> button to select whether to enable the color corrector (<b>On</b>) or disable the color corrector (<b>Off</b>).</li> </ol>
<b>Color Corrector Gain</b>	<b>Switcher Installation &gt; Proc Amp/Color Corrector &gt; Color Corrector Param</b>	Adjust the Gain for the selected color corrector. <ol style="list-style-type: none"> <li>1. Click the <b>Input/Output</b> button and select the input or output BNC that has the color corrector assigned to it that you want to adjust the parameter for.</li> <li>2. Click the <b>Color</b> button and select the individual color component (<b>Red, Green, Blue</b>) you want to adjust, or <b>RGB</b> for all of them.</li> <li>3. Click the <b>Parameter</b> button and select <b>Gain</b>.</li> <li>4. Click the <b>Change Type</b> button and select whether you want to set (<b>Absolute</b>) or reset (<b>Reset</b>) the parameter. Some selections will not be available when you reset the parameter.</li> <li>5. Enter the new gain value in the <b>Value</b> field.</li> </ol>
<b>Color Corrector Gamma</b>	<b>Switcher Installation &gt; Proc Amp/Color Corrector &gt; Color Corrector Param</b>	Adjust the Offset for the selected color corrector. <ol style="list-style-type: none"> <li>1. Click the <b>Input/Output</b> button and select the input or output BNC that has the color corrector assigned to it that you want to adjust the parameter for.</li> <li>2. Click the <b>Color</b> button and select the individual color component (<b>Red, Green, Blue</b>) you want to adjust, or <b>RGB</b> for all of them.</li> <li>3. Click the <b>Parameter</b> button and select <b>Gamma Value</b>.</li> <li>4. Click the <b>Change Type</b> button and select whether you want to set (<b>Absolute</b>) or reset (<b>Reset</b>) the parameter. Some selections will not be available when you reset the parameter.</li> <li>5. Enter the new gamma value in the <b>Value</b> field.</li> </ol>

Event	Location	Description
Color Corrector Gamma Offset	Switcher Installation > Proc Amp/Color Corrector > Color Corrector Param	Adjust the Gamma Offset for the selected color corrector. <ol style="list-style-type: none"> <li>1. Click the <b>Input/Output</b> button and select the input or output BNC that has the color corrector assigned to it that you want to adjust the parameter for.</li> <li>2. Click the <b>Color</b> button and select the individual color component (<b>Red, Green, Blue</b>) you want to adjust, or <b>RGB</b> for all of them.</li> <li>3. Click the <b>Parameter</b> button and select <b>Gamma Offset</b>.</li> <li>4. Click the <b>Change Type</b> button and select whether you want to set (<b>Absolute</b>) or reset (<b>Reset</b>) the parameter. Some selections will not be available when you reset the parameter.</li> <li>5. Enter the new gamma offset value in the <b>Value</b> field.</li> </ol>
Color Corrector Lower Offset	Switcher Installation > Proc Amp/Color Corrector > Color Corrector Param	Adjust the Lower Offset for the selected color corrector. <ol style="list-style-type: none"> <li>1. Click the <b>Input/Output</b> button and select the input or output BNC that has the color corrector assigned to it that you want to adjust the parameter for.</li> <li>2. Click the <b>Color</b> button and select the individual color component (<b>Red, Green, Blue</b>) you want to adjust, or <b>RGB</b> for all of them.</li> <li>3. Click the <b>Parameter</b> button and select <b>Lower Offset</b>.</li> <li>4. Click the <b>Change Type</b> button and select whether you want to set (<b>Absolute</b>) or reset (<b>Reset</b>) the parameter. Some selections will not be available when you reset the parameter.</li> <li>5. Enter the new lower offset value in the <b>Value</b> field.</li> </ol>
Color Corrector Offset	Switcher Installation > Proc Amp/Color Corrector > Color Corrector Param	Adjust the Offset for the selected color corrector. <ol style="list-style-type: none"> <li>1. Click the <b>Input/Output</b> button and select the input or output BNC that has the color corrector assigned to it that you want to adjust the parameter for.</li> <li>2. Click the <b>Color</b> button and select the individual color component (<b>Red, Green, Blue</b>) you want to adjust, or <b>RGB</b> for all of them.</li> <li>3. Click the <b>Parameter</b> button and select <b>Offset</b>.</li> <li>4. Click the <b>Change Type</b> button and select whether you want to set (<b>Absolute</b>) or reset (<b>Reset</b>) the parameter. Some selections will not be available when you reset the parameter.</li> <li>5. Enter the new offset value in the <b>Value</b> field.</li> </ol>
Color Corrector Reset	Switcher Installation > Proc Amp/Color Corrector > Color Corrector Reset	Reset the values for the selected color corrector. <ol style="list-style-type: none"> <li>1. Click the <b>Input/Output</b> button and select the input or output BNC that has the color corrector assigned to it that you want to reset.</li> </ol>
Color Gamut, Input	Switcher Installation > Input > Input Color Gamut	Select the color gamut that video input is in. <ol style="list-style-type: none"> <li>1. Click the <b>Input</b> button and select the input BNC that you want to set the color gamut for.</li> <li>2. Click a <b>Value</b> button to select the whether the input is in BT.709 (<b>709</b>) or BT.2020 (<b>2020</b>).</li> </ol>
Color Gamut, Output	Switcher Installation > Output > Output Color Gamut	Select the color gamut that video output is in. <ol style="list-style-type: none"> <li>1. Click the <b>Output</b> button and select the output BNC that you want to set the color gamut for.</li> <li>2. Click a <b>Value</b> button to select the whether the output is in BT.709 (<b>709</b>) or BT.2020 (<b>2020</b>).</li> </ol>
Color Gamut, Switcher	Switcher Installation > Reference > Switcher Color Gamut	Select the color gamut that the switcher will operate in. <ol style="list-style-type: none"> <li>1. Click a <b>Gamut</b> button to select the whether the switcher operates in BT.709 (<b>709</b>) or BT.2020 (<b>2020</b>).</li> </ol>
Disable Audio Memories	Switcher Installation > Disable Audio Memories	Disable the inclusion of audio attributes in memories. <ol style="list-style-type: none"> <li>1. Click a <b>Value</b> button to select whether audio is included with memory recalls (<b>On</b>), or not (<b>Off</b>).</li> </ol>

Event	Location	Description
Dynamic Range, Input	Switcher Installation > Input > Input Dynamic Range	Select the dynamic range that a video input is in. <ol style="list-style-type: none"> <li>Click the <b>Input</b> button and select the input BNC that you want to set the dynamic range for.</li> <li>Click a <b>Value</b> button to select the dynamic range that the input is in.</li> </ol>
Dynamic Range, Output	Switcher Installation > Output > Output Dynamic Range	Select the dynamic range that a video output is in. <ol style="list-style-type: none"> <li>Click the <b>Output</b> button and select the output BNC that you want to set the dynamic range for.</li> <li>Click a <b>Value</b> button to select the dynamic range that the output is in.</li> </ol>
Dynamic Range, Switcher	Switcher Installation > Reference > Switcher Dynamic Range	Select the dynamic range that the switcher will operate in. <ol style="list-style-type: none"> <li>Click a <b>Dynamic Range</b> button to select the dynamic range that the switcher operates in.</li> </ol>
Frame Delay	Switcher Installation > Input > Frame Delay	Assign a Frame Delay to an input. <ol style="list-style-type: none"> <li>Click the <b>Input</b> button and select the input BNC that you want to assign an frame delay to.</li> <li>Click the <b>Change Type</b> button and select whether you want to set (<b>Absolute</b>) or reset (<b>Reset</b>) the parameter. Some selections will not be available when you reset the parameter.</li> <li>In the <b>Value</b> field, enter the value of the frame delay you want to apply.</li> </ol>
FSFC Assignment	Switcher Installation > Input FSFC Assign	Assign an FSFC to an input BNC. This event is only available if you have fewer FSFCs than inputs. <ol style="list-style-type: none"> <li>Click the <b>FSFC</b> button and select the FSFC resource that you want to assign to an input.</li> <li>Click the <b>Assignment</b> button and select the input that you want to assign the selected FSFC to.</li> </ol>
Input FSFC Assignment	Switcher Installation > Input > Input Type	Assign an FSFC to an input. <ol style="list-style-type: none"> <li>Click the <b>Input</b> button and select the input BNC that you want to assign an FSFC to.</li> <li>Click a <b>ValueType</b> button to assign an FSFC to the input or select (<b>SDI Off</b>) to turn the FSFC off.</li> </ol>
Input FSFC Framing	Switcher Installation > Input > Input Framing	Select the video framing that is applied to the converted video input. <ol style="list-style-type: none"> <li>Click the <b>Input</b> button and select the input BNC that you want to assign the framing to.</li> <li>Click a <b>Type</b> button for the input FSFC that is being used.</li> <li>Click a <b>Value</b> button to assign a type of framing to the input.</li> </ol>
Input Scaler Mode (UHDTV1 Only)	Switcher Installation > Input > Input Scaler Mode	Select the format of the video input to be converted. <ol style="list-style-type: none"> <li>Click the <b>Input</b> button and select the input BNC that you want to assign the scaler to.</li> <li>Click the <b>Value</b> button and select the format of the video input.</li> </ol>
Layer Mode	Switcher Installation > ME > ME Layer Mode	Select whether external layer mode is active for the selected ME. <ol style="list-style-type: none"> <li>Click the <b>ME</b> button for the ME that you want to perform the event on.</li> <li>Click the <b>Change Type</b> button and select whether you want to set (<b>Absolute</b>) or reset (<b>Reset</b>) the parameter. Some selections will not be available when you reset the parameter.</li> <li>Click a <b>Value</b> button to select whether external layer mode is on (<b>On</b>) or not (<b>Off</b>).</li> </ol>
ME Follow	Switcher Installation > ME > ME Follow	Select whether an ME or MiniME™ follows another ME or MiniME™. <ol style="list-style-type: none"> <li>Click the <b>ME</b> button and select the area you want to have follow another area.</li> <li>Click a <b>Follow</b> button to select the ME or MiniME™ that you want to follow the selected area.</li> </ol>

Event	Location	Description
Output Assignment	Switcher Installation > Output > Output Assignment	Assign a source to the selected output BNC. <ol style="list-style-type: none"> <li>1. Click the <b>Output</b> button and select the output BNC that you want to assign a source to.</li> <li>2. Click the <b>Source</b> button and select the source that you want to assign to the selected output BNC.</li> </ol>
Output FSFC Video Format	Switcher Installation > Output > Output UHD Mode	Select a video format for the output FSFC conversion. <ol style="list-style-type: none"> <li>1. Click the <b>Output</b> button and select the output BNC that you want to select a different video format for.</li> <li>2. Click the <b>Value</b> button and select the format you want the output video signal converted to.</li> </ol>
Proc Amp/Color Corrector Reset	Switcher Installation > Proc Amp/Color Corrector > Proc Amp / Color Corrector Reset	Reset the values for the selected proc amp or color corrector. <ol style="list-style-type: none"> <li>1. Click the <b>Input/Output</b> button and select the input or output BNC that has the proc amp or color corrector assigned to it that you want to reset.</li> </ol>
Proc Amp Enable	Switcher Installation > Proc Amp/Color Corrector > Proc Amp Enable	Enable a Proc Amp for a video input or output. <ol style="list-style-type: none"> <li>1. Click the <b>Input/Output</b> button and select the input or output BNC that you want assign a Proc Amp to.</li> <li>2. Click the <b>Change Type</b> button and select whether you want to set <b>(Absolute)</b> or reset <b>(Reset)</b> the parameter. Some selections will not be available when you reset the parameter.</li> <li>3. Click a <b>Value</b> button to select whether to enable the proc amp <b>(On)</b> or disable the proc amp <b>(Off)</b>.</li> </ol>
Proc Amp Gain	Switcher Installation > Proc Amp/Color Corrector > Proc Amp Param	Adjust the gain of a color component for the selected proc amp. <ol style="list-style-type: none"> <li>1. Click the <b>Input/Output</b> button and select the input or output BNC that has the proc amp assigned to it that you want to adjust the parameter for.</li> <li>2. Click the <b>Component</b> button and select the color component you want to adjust the gain for.</li> <li>3. Click the <b>Parameter</b> button and select <b>Gain</b>.</li> <li>4. Click the <b>Change Type</b> button and select whether you want to set <b>(Absolute)</b> or reset <b>(Reset)</b> the parameter. Some selections will not be available when you reset the parameter.</li> <li>5. Enter the new gain value in the <b>Value</b> field.</li> </ol>
Proc Amp Gamma	Switcher Installation > Proc Amp/Color Corrector > Proc Amp Param	Adjust the Gamma for the selected proc amp. <ol style="list-style-type: none"> <li>1. Click the <b>Input/Output</b> button and select the input or output BNC that has the proc amp assigned to it that you want to adjust the parameter for.</li> <li>2. Click the <b>Component</b> button and select <b>YCrCb</b>.</li> <li>3. Click the <b>Parameter</b> button and select <b>Gamma</b>.</li> <li>4. Click the <b>Change Type</b> button and select whether you want to set <b>(Absolute)</b> or reset <b>(Reset)</b> the parameter. Some selections will not be available when you reset the parameter.</li> <li>5. Enter the new gamma value in the <b>Value</b> field.</li> </ol>
Proc Amp Gamma Offset	Switcher Installation > Proc Amp/Color Corrector > Proc Amp Param	Adjust the Gamma for the selected proc amp. <ol style="list-style-type: none"> <li>1. Click the <b>Input/Output</b> button and select the input or output BNC that has the proc amp assigned to it that you want to adjust the parameter for.</li> <li>2. Click the <b>Component</b> button and select <b>YCrCb</b>.</li> <li>3. Click the <b>Parameter</b> button and select <b>Gamma Offset</b>.</li> <li>4. Click the <b>Change Type</b> button and select whether you want to set <b>(Absolute)</b> or reset <b>(Reset)</b> the parameter. Some selections will not be available when you reset the parameter.</li> <li>5. Enter the new gamma offset value in the <b>Value</b> field.</li> </ol>

Event	Location	Description
Proc Amp Hue Rotation	Switcher Installation > Proc Amp/Color Corrector > Proc Amp Hue Rot	Adjust the Hue for the selected proc amp. <ol style="list-style-type: none"> <li>1. Click the <b>Input/Output</b> button and select the input or output BNC that has the proc amp assigned to it that you want to adjust the parameter for.</li> <li>2. Click the <b>Change Type</b> button and select whether you want to set (<b>Absolute</b>) or reset (<b>Reset</b>) the parameter. Some selections will not be available when you reset the parameter.</li> <li>3. Enter a new hue rotation value in the <b>Value</b> field.</li> </ol>
Proc Amp Offset	Switcher Installation > Proc Amp/Color Corrector > Proc Amp Param	Adjust the offset of a color component for the selected proc amp. <ol style="list-style-type: none"> <li>1. Click the <b>Input/Output</b> button and select the input or output BNC that has the proc amp assigned to it that you want to adjust the parameter for.</li> <li>2. Click the <b>Component</b> button and select the color component you want to adjust the offset for.</li> <li>3. Click the <b>Parameter</b> button and select <b>Offset</b>.</li> <li>4. Click the <b>Change Type</b> button and select whether you want to set (<b>Absolute</b>) or reset (<b>Reset</b>) the parameter. Some selections will not be available when you reset the parameter.</li> <li>5. Enter the new offset value in the <b>Value</b> field.</li> </ol>
Proc Amp Reset	Switcher Installation > Proc Amp/Color Corrector > Proc Amp Reset	Reset the values for the selected proc amp. <ol style="list-style-type: none"> <li>1. Click the <b>Input/Output</b> button and select the input or output BNC that has the proc amp assigned to it that you want to reset.</li> </ol>
Reference Source	Switcher Installation > Reference > Video Reference	Select the reference source for the switcher. <ol style="list-style-type: none"> <li>1. Click a <b>Reference Source</b> button to select whether to use an internal (<b>Internal</b>) or external (<b>External</b>) reference source.</li> </ol>
Rotation Mode, Output	Switcher Installation > Output > Output Rotation Mode	Enable video rotation on a selected output. <ol style="list-style-type: none"> <li>1. Click the <b>Output</b> button and select the output BNC that you want to apply rotation to.</li> <li>2. Click a <b>Value</b> button to select the amount of rotation to apply to the output.</li> </ol>
Rotation Zoom, Output	Switcher Installation > Output > Output Rotation	Adjust the size of the rotated output image. <ol style="list-style-type: none"> <li>1. Click the <b>Output</b> button and select the output BNC that you want to adjust the rotation for.</li> <li>2. Click <b>Zoom</b>.</li> <li>3. Click the <b>Change Type</b> button and select whether you want to set (<b>Absolute</b>) or reset (<b>Reset</b>) the parameter. Some selections will not be available when you reset the parameter.</li> <li>4. Enter new size in the <b>Value</b> field.</li> </ol>
Rotation X-Position, Output	Switcher Installation > Output > Output Rotation	Adjust the rotated image along the x-axis. <ol style="list-style-type: none"> <li>1. Click the <b>Output</b> button and select the output BNC that you want to adjust the rotation for.</li> <li>2. Click <b>X-Pos</b>.</li> <li>3. Click the <b>Change Type</b> button and select whether you want to set (<b>Absolute</b>) or reset (<b>Reset</b>) the parameter. Some selections will not be available when you reset the parameter.</li> <li>4. Enter new x-axis offset in the <b>Value</b> field.</li> </ol>

Event	Location	Description
Rotation Y-Position, Output	Switcher Installation > Output > Output Rotation	Adjust the rotated image along the y-axis. <ol style="list-style-type: none"> <li>Click the <b>Output</b> button and select the output BNC that you want to adjust the rotation for.</li> <li>Click <b>Y-Pos</b>.</li> <li>Click the <b>Change Type</b> button and select whether you want to set (<b>Absolute</b>) or reset (<b>Reset</b>) the parameter. Some selections will not be available when you reset the parameter.</li> <li>Enter new y-axis offset in the <b>Value</b> field.</li> </ol>
Source Substitution, Bus	Switcher Installation > Source Substitution > Source Bus Subst	Set a bus source substitution for the substitution table. <ol style="list-style-type: none"> <li>Click the <b>Source</b> button and select the source that you want to set a substitution for.</li> <li>Click the <b>ME</b> button and select the area that the bus you want to set up the substitution for is on.</li> <li>Click the <b>Bus/Keyer</b> button and select the bus (<b>Background</b> or <b>Preset</b>) or keyer for the substitution.</li> <li>If you selected <b>Keyer</b>, click the <b>Bus</b> button and select the video (<b>Video</b>) or alpha (<b>Alpha</b>) bus that you want to substitute for</li> <li>Click the <b>Subst</b> button and select the source you want to substitute for the selected source.</li> </ol>
Source Substitution, Delete	Switcher Installation > Source Substitution > Delete Subst Table	Delete the entire substitution table.
Source Substitution, ME	Switcher Installation > Source Substitution > Source ME Subst	Set an ME source substitution for the substitution table. <ol style="list-style-type: none"> <li>Click the <b>Source</b> button and select the source that you want to set a substitution for.</li> <li>Click the <b>ME</b> button and select the ME or MiniME™ that you want to assign a substitution source to.</li> <li>Click the <b>Subst</b> button and select the source you want to substitute for the selected source.</li> </ol>
Switching Field	Switcher Installation > Field Dominance	Select the field that a video transition will be performed on. <ol style="list-style-type: none"> <li>Click a <b>Switch Field</b> button to select whether video transitions are performed on field 1 only (<b>Field 1</b>), field 2 only (<b>Field 2</b>), or the current field (<b>Both</b>).</li> </ol>
TSL Address	Switcher Installation > Input > TSL Address	Assign a TSL id to an input. <ol style="list-style-type: none"> <li>Click the <b>Input</b> button and select the input BNC that you want to set the TSL id for.</li> <li>Click the <b>Change Type</b> button and select whether you want to set (<b>Absolute</b>) or reset (<b>Reset</b>) the parameter. Some selections will not be available when you reset the parameter.</li> <li>Enter the TSL id in the <b>Value</b> field.</li> </ol>
TSL Tally MultiViewer Display Mode (Name)	Switcher Installation > Input > TSL Tally Mode	Assign a TSL id to an input. <ol style="list-style-type: none"> <li>Click the <b>Input</b> button and select the input BNC that you want to set the TSL mode for.</li> <li>Click a <b>TSL Tally</b> button to select whether the MultiViewer shows the Mnemonic name (<b>Name Only</b>), TSL name (<b>Tally Only</b>), or both (<b>Both</b>).</li> </ol>
Video Mode	Switcher Installation > Reference > Video Format	Select the video format that the switcher will operate in. <ol style="list-style-type: none"> <li>Click the <b>Video Mode</b> button and select the video format for the switcher.</li> </ol>



## MultiViewer

Event	Location	Description
<b>MultiViewer Box — Apply to All</b>	<b>MultiViewer &gt; Box &gt; MV Box Apply To All</b>	<p>Apply the configurations for the selected box to all boxed on the selected MultiViewer.</p> <ol style="list-style-type: none"> <li>1. Click a <b>MultiViewer</b> button to select which MultiViewer you want to perform the event on.</li> <li>2. Click the <b>Box</b> button and select the box that you want perform the event on.</li> <li>3. Click <b>Apply to All</b>.</li> </ol>
<b>MultiViewer Box — Aspect Ratio Markers</b>	<b>MultiViewer &gt; Box &gt; MV Box Aspect Ratio</b>	<p>Select whether aspect ratio markers are shown for the selected box on the selected MultiViewer.</p> <ol style="list-style-type: none"> <li>1. Click a <b>MultiViewer</b> button to select which MultiViewer you want to perform the event on.</li> <li>2. Click the <b>Box</b> button and select the box that you want perform the event on.</li> <li>3. Click the <b>Change Type</b> button and select whether you want to set (<b>Absolute</b>) or reset (<b>Reset</b>) the parameter. Some selections will not be available when you reset the parameter.</li> <li>4. Click a <b>Value</b> button and select whether aspect ratio markers are shown (<b>On</b>) or not (<b>Off</b>).</li> </ol>
<b>MultiViewer Box — Border</b>	<b>MultiViewer &gt; Box &gt; MV Box Border Mode</b>	<p>Select the type of border you want to apply to the selected box on the selected MultiViewer.</p> <ol style="list-style-type: none"> <li>1. Click a <b>MultiViewer</b> button to select which MultiViewer you want to perform the event on.</li> <li>2. Click the <b>Box</b> button and select the box that you want perform the event on.</li> <li>3. Click a <b>Border Mode</b> button and select whether the border around the selected box is white (<b>White</b>), black (<b>Black</b>), or if there is no border (<b>Off</b>).</li> </ol>
<b>MultiViewer Box — Green Tally (Preview)</b>	<b>MultiViewer &gt; Box &gt; MV Box Preview Tally</b>	<p>Select whether a green (preview) tally is shown for the selected box on the selected MultiViewer.</p> <ol style="list-style-type: none"> <li>1. Click a <b>MultiViewer</b> button to select which MultiViewer you want to perform the event on.</li> <li>2. Click the <b>Box</b> button and select the box that you want perform the event on.</li> <li>3. Click the <b>Change Type</b> button and select whether you want to set (<b>Absolute</b>) or reset (<b>Reset</b>) the parameter. Some selections will not be available when you reset the parameter.</li> <li>4. Click a <b>Value</b> button and select whether a green tally is shown on the selected box (<b>On</b>) or not (<b>Off</b>).</li> </ol>
<b>MultiViewer Box — Label</b>	<b>MultiViewer &gt; Box &gt; MV Box Label</b>	<p>Select whether the source label is on or off for the selected box on the selected MultiViewer.</p> <ol style="list-style-type: none"> <li>1. Click a <b>MultiViewer</b> button to select which MultiViewer you want to perform the event on.</li> <li>2. Click the <b>Box</b> button and select the box that you want perform the event on.</li> <li>3. Click the <b>Change Type</b> button and select whether you want to set (<b>Absolute</b>) or reset (<b>Reset</b>) the parameter. Some selections will not be available when you reset the parameter.</li> <li>4. Click a <b>Value</b> button and select whether the label on the selected box is on (<b>On</b>) or not (<b>Off</b>).</li> </ol>

Event	Location	Description
<b>MultiViewer Box — Label Mode</b>	<b>MultiViewer &gt; Box &gt; MV Box Label Mode</b>	<p>Select what source name is shown on the label for the selected box on the selected MultiViewer. This event only applies to the Carbonite eXtreme.</p> <ol style="list-style-type: none"> <li>1. Click a <b>MultiViewer</b> button to select which MultiViewer you want to perform the event on.</li> <li>2. Click the <b>Box</b> button and select the box that you want perform the event on.</li> <li>3. Click the <b>Change Type</b> button and select whether you want to set (<b>Absolute</b>) or reset (<b>Reset</b>) the parameter. Some selections will not be available when you reset the parameter.</li> <li>4. Click a <b>Label Mode</b> button and select whether the name comes from the switcher (<b>Switcher</b>), the router (<b>Router</b>), or both are shown (<b>Both</b>).</li> </ol>
<b>MultiViewer Box — Label Position</b>	<b>MultiViewer &gt; Box &gt; MV Box Label Position</b>	<p>Select the position of the source label for the selected box on the selected MultiViewer.</p> <ol style="list-style-type: none"> <li>1. Click a <b>MultiViewer</b> button to select which MultiViewer you want to perform the event on.</li> <li>2. Click the <b>Box</b> button and select the box that you want perform the event on.</li> <li>3. Click the <b>Change Type</b> button and select whether you want to set (<b>Absolute</b>) or reset (<b>Reset</b>) the parameter. Some selections will not be available when you reset the parameter.</li> <li>4. Click a <b>Value</b> button and select whether the label on the selected box is at the top (<b>Top</b>) or bottom (<b>Bottom</b>).</li> </ol>
<b>MultiViewer Box — Label Transparency</b>	<b>MultiViewer &gt; MV Label Transp</b>	<p>Select transparency for the background behind the source labels on the selected MultiViewer.</p> <ol style="list-style-type: none"> <li>1. Click a <b>MultiViewer</b> button to select which MultiViewer you want to perform the event on.</li> <li>2. Click the <b>Change Type</b> button and select whether you want to set (<b>Absolute</b>) or reset (<b>Reset</b>) the parameter. Some selections will not be available when you reset the parameter.</li> <li>3. Enter the amount of transparency in the <b>Value (%)</b> field.</li> </ol>
<b>MultiViewer Box — Red Tally (On-Air)</b>	<b>MultiViewer &gt; Box &gt; MV Box On-Air Tally</b>	<p>Select whether a red (on-air) tally is shown for the selected box on the selected MultiViewer.</p> <ol style="list-style-type: none"> <li>1. Click a <b>MultiViewer</b> button to select which MultiViewer you want to perform the event on.</li> <li>2. Click the <b>Box</b> button and select the box that you want perform the event on.</li> <li>3. Click the <b>Change Type</b> button and select whether you want to set (<b>Absolute</b>) or reset (<b>Reset</b>) the parameter. Some selections will not be available when you reset the parameter.</li> <li>4. Click a <b>Value</b> button and select whether a red tally is shown on the selected box (<b>On</b>) or not (<b>Off</b>).</li> </ol>
<b>MultiViewer Box — Video Source</b>	<b>MultiViewer &gt; Box &gt; MV Box Source</b>	<p>Assign a source to one of the boxes on the selected MultiViewer.</p> <ol style="list-style-type: none"> <li>1. Click a <b>MultiViewer</b> button to select which MultiViewer you want to perform the event on.</li> <li>2. Click the <b>Box</b> button and select the box that you want perform the event on.</li> <li>3. Click the <b>Value</b> button and select the source that you want to assign to the box.</li> </ol>

Event	Location	Description
MultiViewer — Clip	MultiViewer > MV Keyer Clip	<p>Select the amount of clipping to be applied to the overlay source on the selected MultiViewer.</p> <ol style="list-style-type: none"> <li>1. Click a <b>MultiViewer</b> button to select which MultiViewer you want to perform the event on.</li> <li>2. Click the <b>Change Type</b> button and select whether you want to set (<b>Absolute</b>) or reset (<b>Reset</b>) the parameter. Some selections will not be available when you reset the parameter.</li> <li>3. Enter the amount of clipping to be applied in the <b>Value</b> field.</li> </ol>
MultiViewer Clock — Background Color (HSL)	MultiViewer > Clock > MV Clock (HSL Color)	<p>Select the custom color for the background of the clock on the selected MultiViewer.</p> <ol style="list-style-type: none"> <li>1. Click a <b>MultiViewer</b> button to select which MultiViewer you want to perform the event on.</li> <li>2. Click the <b>Clock Area</b> button and select <b>Background</b>.</li> <li>3. Click the <b>Change Type</b> button and select whether you want to set (<b>Absolute</b>) or reset (<b>Reset</b>) the parameter. Some selections will not be available when you reset the parameter.</li> <li>4. Click the <b>Component</b> button and select the HSL component you want to assign a value to. A value should be applied to all three components.</li> <li>5. Enter a value for the selected component in the <b>Value (%)</b> field.</li> </ol>
MultiViewer Clock — Background Color (Preset)	MultiViewer > Clock > MV Clock (Preset Color)	<p>Select a preset color for the background of the clock on the selected MultiViewer.</p> <ol style="list-style-type: none"> <li>1. Click a <b>MultiViewer</b> button to select which MultiViewer you want to perform the event on.</li> <li>2. Click <b>Background</b>.</li> <li>3. Click the <b>Color</b> button and select the color you want to use.</li> </ol>
MultiViewer Clock — Countdown Timer Direction	MultiViewer > Clock > Countdown Timer Direction	<p>Select the direction you want to countdown timer to count in.</p> <ol style="list-style-type: none"> <li>1. Click the <b>Timer</b> button and select the timer you want to configure.</li> <li>2. Click a <b>Timer Direction</b> button to select whether the timer counts down from a preset value (<b>Down</b>), up from zero (<b>Up</b>), or down from a preset value and then up from zero (<b>Down &gt; Up</b>).</li> </ol>
MultiViewer Clock — Countdown Timer Reset	MultiViewer > Clock > Countdown Timer Reset	<p>Reset the selected timer.</p> <ol style="list-style-type: none"> <li>1. Click the <b>Timer Reset</b> button and select the timer you want to reset.</li> </ol>
MultiViewer Clock — Countdown Timer State	MultiViewer > Clock > Countdown Timer State	<p>Select the direction you want to countdown timer to count in.</p> <ol style="list-style-type: none"> <li>1. Click the <b>Timer</b> button and select the timer you want to configure.</li> <li>2. Click a <b>Timer State</b> button to select whether to send the pause (<b>Pause</b>), or start (<b>Run</b>) command to the timer.</li> </ol>
MultiViewer Clock — Foreground Color (HSL)	MultiViewer > Clock > MV Clock (HSL Color)	<p>Select the custom color for the lettering of the clock on the selected MultiViewer.</p> <ol style="list-style-type: none"> <li>1. Click a <b>MultiViewer</b> button to select which MultiViewer you want to perform the event on.</li> <li>2. Click the <b>Clock Area</b> button and select <b>Foreground</b>.</li> <li>3. Click the <b>Change Type</b> button and select whether you want to set (<b>Absolute</b>) or reset (<b>Reset</b>) the parameter. Some selections will not be available when you reset the parameter.</li> <li>4. Click the <b>Component</b> button and select the HSL component you want to assign a value to. A value should be applied to all three components.</li> <li>5. Enter a value for the selected component in the <b>Value (%)</b> field.</li> </ol>

Event	Location	Description
<b>MultiViewer Clock — Foreground Color (Preset)</b>	<b>MultiViewer &gt; Clock &gt; MV Clock (Preset Color)</b>	Select a preset color for the lettering of the clock on the selected MultiViewer. <ol style="list-style-type: none"> <li>1. Click a <b>MultiViewer</b> button to select which MultiViewer you want to perform the event on.</li> <li>2. Click <b>Foreground</b>.</li> <li>3. Click the <b>Color</b> button and select the color you want to use.</li> </ol>
<b>MultiViewer Clock — Format</b>	<b>MultiViewer &gt; Clock &gt; MV Clock Format</b>	Select the hour format for the clock on the selected MultiViewer. <ol style="list-style-type: none"> <li>1. Click a <b>MultiViewer</b> button to select which MultiViewer you want to perform the event on.</li> <li>2. Click a <b>Value</b> button and select whether the clock shows 24-hour (<b>24-Hours</b>), 12-hour with am/pm (<b>12-Hour AM/PM</b>), or simple 12-hour (<b>12-Hour</b>) clock.</li> </ol>
<b>MultiViewer Clock — Mode</b>	<b>MultiViewer &gt; Clock &gt; MV Clock Mode</b>	Select whether the clock shows timecode or system time on the selected MultiViewer. <ol style="list-style-type: none"> <li>1. Click a <b>MultiViewer</b> button to select which MultiViewer you want to perform the event on.</li> <li>2. Click a <b>Clock Mode</b> button and select whether the clock shows timecode (<b>Timecode</b>), system time (<b>System</b>), a countdown timer (<b>CountDown</b>), or is off (<b>Off</b>).</li> </ol>
<b>MultiViewer Clock — MV Timer</b>	<b>MultiViewer &gt; Clock &gt; MV Timer</b>	Select which countdown timer you want a MultiViewer to use. <ol style="list-style-type: none"> <li>1. Click a <b>MultiViewer</b> button to select which MultiViewer you want to perform the event on.</li> <li>2. Click the <b>Timer</b> button and select the timer (1-5) that you want to assign to the selected MultiViewer.</li> </ol>
<b>MultiViewer Clock — Size</b>	<b>MultiViewer &gt; Clock &gt; MV Clock Param</b>	Select the size of the clock on the selected MultiViewer. <ol style="list-style-type: none"> <li>1. Click a <b>MultiViewer</b> button to select which MultiViewer you want to perform the event on.</li> <li>2. Click <b>Clock Size</b>.</li> <li>3. Click the <b>Change Type</b> button and select whether you want to set (<b>Absolute</b>) or reset (<b>Reset</b>) the parameter. Some selections will not be available when you reset the parameter.</li> <li>4. Enter the size of the clock in the <b>Value (%)</b> field.</li> </ol>
<b>MultiViewer Clock — Timecode Frame Count</b>	<b>MultiViewer &gt; Clock &gt; MV Clock Frame Count</b>	Select whether number of frames for a timecode are shown on the selected MultiViewer. <ol style="list-style-type: none"> <li>1. Click a <b>MultiViewer</b> button to select which MultiViewer you want to perform the event on.</li> <li>2. Click the <b>Change Type</b> button and select whether you want to set (<b>Absolute</b>) or reset (<b>Reset</b>) the parameter. Some selections will not be available when you reset the parameter.</li> <li>3. Click a <b>Value</b> button and select whether the frame count is shown (<b>On</b>) or not (<b>Off</b>).</li> </ol>
<b>MultiViewer Clock — Timer Set Time (Minutes)</b>	<b>MultiViewer &gt; Clock &gt; Timer Set Times</b>	Set the starting time in minutes for the timer. <ol style="list-style-type: none"> <li>1. Click the <b>Timer</b> button and select the timer you want to configure.</li> <li>2. Click <b>Set Time (Minutes)</b>.</li> <li>3. Click the <b>Change Type</b> button and select whether you want to set (<b>Absolute</b>) or reset (<b>Reset</b>) the parameter. Some selections will not be available when you reset the parameter.</li> <li>4. In the <b>Value</b> field, enter the number of minutes that you want to start the timer at.</li> </ol>

Event	Location	Description
<b>MultiViewer Clock — Timer Set Time (Seconds)</b>	<b>MultiViewer &gt; Clock &gt; Timer Set Times</b>	<p>Set the starting time in seconds for the timer.</p> <ol style="list-style-type: none"> <li>1. Click the <b>Timer</b> button and select the timer you want to configure.</li> <li>2. Click <b>Set Time (Seconds)</b>.</li> <li>3. Click the <b>Change Type</b> button and select whether you want to set <b>(Absolute)</b> or reset <b>(Reset)</b> the parameter. Some selections will not be available when you reset the parameter.</li> <li>4. In the <b>Value</b> field, enter the number of seconds (0-59) that you want to start the timer at. If you want a value that is larger than 59 seconds you must insert a command for minutes and then a command for seconds.</li> </ol>
<b>MultiViewer Clock — X-Position</b>	<b>MultiViewer &gt; Clock &gt; MV Clock Param</b>	<p>Select the horizontal position of the clock on the selected MultiViewer.</p> <ol style="list-style-type: none"> <li>1. Click a <b>MultiViewer</b> button to select which MultiViewer you want to perform the event on.</li> <li>2. Click <b>Clock X-Pos</b>.</li> <li>3. Click the <b>Change Type</b> button and select whether you want to set <b>(Absolute)</b> or reset <b>(Reset)</b> the parameter. Some selections will not be available when you reset the parameter.</li> <li>4. Enter the horizontal position of the clock in the <b>Value (%)</b> field.</li> </ol>
<b>MultiViewer Clock — Y-Position</b>	<b>MultiViewer &gt; Clock &gt; MV Clock Param</b>	<p>Select the vertical position of the clock on the selected MultiViewer.</p> <ol style="list-style-type: none"> <li>1. Click a <b>MultiViewer</b> button to select which MultiViewer you want to perform the event on.</li> <li>2. Click <b>Clock Y-Pos</b>.</li> <li>3. Click the <b>Change Type</b> button and select whether you want to set <b>(Absolute)</b> or reset <b>(Reset)</b> the parameter. Some selections will not be available when you reset the parameter.</li> <li>4. Enter the vertical position of the clock in the <b>Value (%)</b> field.</li> </ol>
<b>MultiViewer — Follow</b>	<b>MultiViewer &gt; MV Follow</b>	<p>Select whether a MultiViewer follows the layout of a Canvas.</p> <ol style="list-style-type: none"> <li>1. Click a <b>MultiViewer</b> button to select which MultiViewer you want to perform the event on.</li> <li>2. Click a <b>Follow</b> button to select which Canvas the MultiViewer will follow or select <b>Off</b> to have the MultiViewer operate normally.</li> </ol>
<b>MultiViewer — FSFC Label</b>	<b>MultiViewer &gt; MV FSFC Label</b>	<p>Select whether FSFC is shown on the label on the selected MultiViewer when a source has an FSFC applies to it.</p> <ol style="list-style-type: none"> <li>1. Click a <b>MultiViewer</b> button to select which MultiViewer you want to perform the event on.</li> <li>2. Click the <b>Change Type</b> button and select whether you want to set <b>(Absolute)</b> or reset <b>(Reset)</b> the parameter. Some selections will not be available when you reset the parameter.</li> <li>3. Click a <b>Value</b> button to select whether FSFC is shown on the label (<b>On</b>) or not (<b>Off</b>).</li> </ol>
<b>MultiViewer — Layout</b>	<b>MultiViewer &gt; MV Layout</b>	<p>Select a layout for the selected MultiViewer.</p> <ol style="list-style-type: none"> <li>1. Click a <b>MultiViewer</b> button to select which MultiViewer you want to perform the event on.</li> <li>2. Click the <b>Layout</b> button and select the layout you want to use.</li> </ol>
<b>MultiViewer — Overlay</b>	<b>MultiViewer &gt; MV Overlay</b>	<p>Select whether the MultiViewer overlay is turned on or not.</p> <ol style="list-style-type: none"> <li>1. Click a <b>MultiViewer</b> button to select which MultiViewer you want to perform the event on.</li> <li>2. Click the <b>Change Type</b> button and select whether you want to set <b>(Absolute)</b> or reset <b>(Reset)</b> the parameter. Some selections will not be available when you reset the parameter.</li> <li>3. Click a <b>Value</b> button to select whether the overlay is turned on (<b>On</b>) or not (<b>Off</b>).</li> </ol>

Event	Location	Description
MultiViewer — Shift	MultiViewer > MV Shift	Select whether the sources on the selected MultiViewer are shifted, or not. <ol style="list-style-type: none"> <li>1. Click a <b>MultiViewer</b> button to select which MultiViewer you want to perform the event on.</li> <li>2. Click the <b>Change Type</b> button and select whether you want to set (<b>Absolute</b>) or reset (<b>Reset</b>) the parameter. Some selections will not be available when you reset the parameter.</li> <li>3. Click a <b>Value</b> button to select whether the MultiViewer shows the shifted sources (<b>On</b>) or not (<b>Off</b>).</li> </ol>
MultiViewer — Shift Panel	MultiViewer > MV Shift Panel	Select which control panel the MultiViewer shift is following. When <b>Shift</b> is press on the selected panel, the selected MultiViewer shifts. <ol style="list-style-type: none"> <li>1. Click a <b>MultiViewer</b> button to select which MultiViewer you want to perform the event on.</li> <li>2. Click <b>Panel</b> and click the control panel you want to shift to follow or click <b>Off</b> to have shift not follow any panel.</li> </ol>
MultiViewer — Tally Display	MultiViewer > MV Tally Display	Select how the tallies are shown on the selected MultiViewer. <ol style="list-style-type: none"> <li>1. Click a <b>MultiViewer</b> button to select which MultiViewer you want to perform the event on.</li> <li>2. Click a <b>Tally Display</b> button to select whether tallies are shown as a border around the box (<b>Box</b>), as boxes on either side of the label (<b>Label</b>), or as boxes on either side of the label but swapped (<b>Label Reverse</b>).</li> </ol>
MultiViewer — ViewControl Shift	MultiViewer > View Control Shift	Select whether the ViewControl sources are shifted, or not. <ol style="list-style-type: none"> <li>1. Click a <b>MultiViewer</b> button to select which MultiViewer you want to perform the event on.</li> <li>2. Click the <b>Change Type</b> button and select whether you want to set (<b>Absolute</b>) or reset (<b>Reset</b>) the parameter. Some selections will not be available when you reset the parameter.</li> <li>3. Click a <b>Value</b> button to select whether ViewControl shows the shifted sources (<b>On</b>) or not (<b>Off</b>).</li> </ol>

## RAVE Audio Mixer Custom Controls

### Audio Mixer (RAVE)

#### Channel Events

Event	Location	Description
AFV	Audio Mixer > Channel > AFV Enable	Turn on Audio Follow Video (AFV) for a channel. <ol style="list-style-type: none"> <li>1. Click the <b>InnerAudioMixerChannel</b> button and select the channel you want to send the command to.</li> <li>2. Click the <b>Change Type</b> button and select whether you want to set (<b>Absolute</b>) or reset (<b>Reset</b>) the parameter. Some selections will not be available when you reset the parameter.</li> <li>3. Click the <b>Value</b> button to turn on AFV for the selected channel (<b>On</b>), or turn it off (<b>Off</b>).</li> </ol>
AFV Volume	Audio Mixer > Channel > AFV Volume	Set the level for AFV for a channel. <ol style="list-style-type: none"> <li>1. Click the <b>Change Type</b> button and select whether you want to set (<b>Absolute</b>) or reset (<b>Reset</b>) the parameter. Some selections will not be available when you reset the parameter.</li> <li>2. In the <b>AFV Volume (dB)</b> field, enter the level for the selected channel.</li> <li>3. Click the <b>InnerAudioMixerChannel</b> button and select the channel you want to send the command to.</li> </ol>

Event	Location	Description
<b>Aux Pre/Post</b>	<b>Audio Mixer &gt; Channel &gt; Aux Pre/Post</b>	<p>Set whether the source on an aux is take before or after the fader.</p> <ol style="list-style-type: none"> <li>1. Click the <b>InnerAudioMixerOutput</b> button and select the mixer output that you want to send the command to.</li> <li>2. Click the <b>Change Type</b> button and select whether you want to set (<b>Absolute</b>) or reset (<b>Reset</b>) the parameter. Some selections will not be available when you reset the parameter.</li> <li>3. Click the <b>Value</b> button to set the aux source to post-fader (<b>Post</b>), or pre-fader (<b>Pre</b>).</li> <li>4. Click the <b>InnerAudioMixerChannel</b> button and select the channel you want to send the command to.</li> </ol>
<b>Balance/Pan</b>	<b>Audio Mixer &gt; Channel &gt; Balance/Pan</b>	<p>Set the balance or pan for the selected channel.</p> <ol style="list-style-type: none"> <li>1. Click the <b>InnerAudioMixerOutput</b> button and select the mixer output that you want to send the command to.</li> <li>2. Click the <b>Change Type</b> button and select whether you want to set (<b>Absolute</b>) or reset (<b>Reset</b>) the parameter. Some selections will not be available when you reset the parameter.</li> <li>3. In the <b>Value (%)</b> field, enter the balance or pan you want to apply.</li> <li>4. Click the <b>InnerAudioMixerChannel</b> button and select the channel you want to send the command to.</li> </ol>
<b>Input Volume</b>	<b>Audio Mixer &gt; Channel &gt; Volume</b>	<p>Set the level for the selected channel.</p> <ol style="list-style-type: none"> <li>1. Click the <b>Change Type</b> button and select whether you want to set (<b>Absolute</b>) or reset (<b>Reset</b>) the parameter. Some selections will not be available when you reset the parameter.</li> <li>2. In the <b>Volume (dB)</b> field, enter the level you want to set.</li> <li>3. Click the <b>InnerAudioMixerOutput</b> button and select the mixer output that you want to send the command to.</li> <li>4. Click the <b>InnerAudioMixerChannel</b> button and select the channel you want to send the command to.</li> </ol>
<b>Mute</b>	<b>Audio Mixer &gt; Channel &gt; Mute</b>	<p>Mute the selected channel.</p> <ol style="list-style-type: none"> <li>1. Click the <b>InnerAudioMixerOutput</b> button and select the mixer output that you want to send the command to.</li> <li>2. Click the <b>Change Type</b> button and select whether you want to set (<b>Absolute</b>) or reset (<b>Reset</b>) the parameter. Some selections will not be available when you reset the parameter.</li> <li>3. Click the <b>Value</b> button to mute the selected channel (<b>On</b>), or un-mute it (<b>Off</b>).</li> <li>4. Click the <b>InnerAudioMixerChannel</b> button and select the channel you want to send the command to.</li> </ol>
<b>PFL</b>	<b>Audio Mixer &gt; Channel &gt; PFL</b>	<p>Set Pre Fader Listen (PFL) for a channel.</p> <ol style="list-style-type: none"> <li>1. Click the <b>InnerAudioMixerChannel</b> button and select the channel you want to send the command to.</li> <li>2. Click the <b>Change Type</b> button and select whether you want to set (<b>Absolute</b>) or reset (<b>Reset</b>) the parameter. Some selections will not be available when you reset the parameter.</li> <li>3. Click the <b>Value</b> button to turn on PFL for the selected channel (<b>On</b>), or turn it off (<b>Off</b>).</li> </ol>

Event	Location	Description
<b>Solo</b>	<b>Audio Mixer &gt; Channel &gt; Solo</b>	<p>Set the selected channel to solo.</p> <ol style="list-style-type: none"> <li>1. Click the <b>InnerAudioMixerOutput</b> button and select the mixer output that you want to send the command to.</li> <li>2. Click the <b>Change Type</b> button and select whether you want to set (<b>Absolute</b>) or reset (<b>Reset</b>) the parameter. Some selections will not be available when you reset the parameter.</li> <li>3. Click the <b>Value</b> button to solo the selected channel (<b>On</b>), or un-solo it (<b>Off</b>).</li> <li>4. Click the <b>InnerAudioMixerChannel</b> button and select the channel you want to send the command to.</li> </ol>

### Noise Gate Events

Event	Location	Description
<b>Attack</b>	<b>Audio Mixer &gt; Noise Gate &gt; Attack</b>	<p>Select the amount of time (ms) you want to pass between when the noise gate is triggered to open (pass the threshold) and the attenuation being fully released.</p> <ol style="list-style-type: none"> <li>1. Click the <b>Change Type</b> button and select whether you want to set (<b>Absolute</b>) or reset (<b>Reset</b>) the parameter. Some selections will not be available when you reset the parameter.</li> <li>2. Enter the time for the event in the <b>Transition Time (ms)</b> field.</li> <li>3. Click the <b>InnerAudioMixerChannel</b> button and select the channel you want to send the command to.</li> </ol>
<b>Bypass</b>	<b>Audio Mixer &gt; Noise Gate &gt; Bypass</b>	<p>Bypass the noise gate.</p> <ol style="list-style-type: none"> <li>1. Click the <b>InnerAudioMixerChannel</b> button and select the channel you want to send the command to.</li> <li>2. Click the <b>Change Type</b> button and select whether you want to set (<b>Absolute</b>) or reset (<b>Reset</b>) the parameter. Some selections will not be available when you reset the parameter.</li> <li>3. Click a <b>Value</b> button to turn bypass on (<b>On</b>) or off (<b>Off</b>).</li> </ol>
<b>Default All NG</b>	<b>Audio Mixer &gt; Noise Gate &gt; Default All NG</b>	<p>Default the NG for all audio channels.</p>
<b>Default NG Channel</b>	<b>Audio Mixer &gt; Noise Gate &gt; Default NG Selection</b>	<p>Default the NG for a selected audio channel.</p> <ol style="list-style-type: none"> <li>1. Click the <b>InnerAudioMixerChannel</b> button and select the channel you want to send the command to.</li> </ol>
<b>Depth</b>	<b>Audio Mixer &gt; Noise Gate &gt; Attack</b>	<p>Select the level that the audio signal must go below the threshold before the noise gate is triggered to close.</p> <ol style="list-style-type: none"> <li>1. Click the <b>Change Type</b> button and select whether you want to set (<b>Absolute</b>) or reset (<b>Reset</b>) the parameter. Some selections will not be available when you reset the parameter.</li> <li>2. Enter the new gain value in n the <b>Gain (dB)</b> field.</li> <li>3. Click the <b>InnerAudioMixerChannel</b> button and select the channel you want to send the command to.</li> </ol>
<b>Hold</b>	<b>Audio Mixer &gt; Noise Gate &gt; Hold</b>	<p>Select the amount of time (s) between when the noise gate is triggered to close (level is below the Depth) and the Release is applied.</p> <ol style="list-style-type: none"> <li>1. Click the <b>Change Type</b> button and select whether you want to set (<b>Absolute</b>) or reset (<b>Reset</b>) the parameter. Some selections will not be available when you reset the parameter.</li> <li>2. Enter the time for the event in the <b>Transition Time (ms)</b> field.</li> <li>3. Click the <b>InnerAudioMixerChannel</b> button and select the channel you want to send the command to.</li> </ol>



Event	Location	Description
Release	Audio Mixer > Noise Gate > Release	<p>Select the amount of time (ms) you want to pass after the Hold is applied and the gate is fully closed (full Reduction is applied).</p> <ol style="list-style-type: none"> <li>1. Click the <b>Change Type</b> button and select whether you want to set (<b>Absolute</b>) or reset (<b>Reset</b>) the parameter. Some selections will not be available when you reset the parameter.</li> <li>2. Enter the time for the event in the <b>Transition Time (ms)</b> field.</li> <li>3. Click the <b>InnerAudioMixerChannel</b> button and select the channel you want to send the command to.</li> </ol>
Threshold	Audio Mixer > Noise Gate > Threshold	<p>Select the level (-dB) at which the noise gate opens.</p> <ol style="list-style-type: none"> <li>1. Click the <b>Change Type</b> button and select whether you want to set (<b>Absolute</b>) or reset (<b>Reset</b>) the parameter. Some selections will not be available when you reset the parameter.</li> <li>2. Enter the new gain value in n the <b>Gain (dB)</b> field.</li> <li>3. Click the <b>InnerAudioMixerChannel</b> button and select the channel you want to send the command to.</li> </ol>

## Ducking Events

Event	Location	Description
Attack	Audio Mixer > Mixer Ducking > Ducking Mode	<p>Select the amount of time (ms) you want to pass between when ducking is triggered to apply (pass the threshold) and the attenuation being fully applied to the mix.</p> <ol style="list-style-type: none"> <li>1. Click the <b>Change Type</b> button and select whether you want to set (<b>Absolute</b>) or reset (<b>Reset</b>) the parameter. Some selections will not be available when you reset the parameter.</li> <li>2. Enter the new gain value in n the <b>Gain (dB)</b> field.</li> <li>3. Click the <b>InnerAudioMixerChannel</b> button and select the channel you want to send the command to.</li> </ol>
Default All Ducking	Audio Mixer > Mixer Ducking > Ducking Mode	<p>Default the ducking for all audio channels.</p> <ol style="list-style-type: none"> <li>1. Click the <b>Change Type</b> button and select whether you want to set (<b>Absolute</b>) or reset (<b>Reset</b>) the parameter. Some selections will not be available when you reset the parameter.</li> <li>2. Enter the new gain value in n the <b>Gain (dB)</b> field.</li> <li>3. Click the <b>InnerAudioMixerChannel</b> button and select the channel you want to send the command to.</li> </ol>
Default Ducking Channel	Audio Mixer > Mixer Ducking > Ducking Mode	<p>Default the ducking for a selected audio channel.</p> <ol style="list-style-type: none"> <li>1. Click the <b>Change Type</b> button and select whether you want to set (<b>Absolute</b>) or reset (<b>Reset</b>) the parameter. Some selections will not be available when you reset the parameter.</li> <li>2. Enter the new gain value in n the <b>Gain (dB)</b> field.</li> <li>3. Click the <b>InnerAudioMixerChannel</b> button and select the channel you want to send the command to.</li> </ol>
Depth	Audio Mixer > Mixer Ducking > Ducking Mode	<p>Select the level that the audio signal must go below the threshold before the ducking is removed.</p> <ol style="list-style-type: none"> <li>1. Click the <b>Change Type</b> button and select whether you want to set (<b>Absolute</b>) or reset (<b>Reset</b>) the parameter. Some selections will not be available when you reset the parameter.</li> <li>2. Enter the new gain value in n the <b>Gain (dB)</b> field.</li> <li>3. Click the <b>InnerAudioMixerChannel</b> button and select the channel you want to send the command to.</li> </ol>

Event	Location	Description
<b>Ducking Mode</b>	<b>Audio Mixer &gt; Mixer Ducking &gt; Ducking Mode</b>	Turn on Ducking for the selected channel. <ol style="list-style-type: none"> <li>1. Click the <b>InnerAudioMixerChannel</b> button and select the channel you want to send the command to.</li> <li>2. Click <b>Ducking Mode</b>.</li> </ol>
<b>Hold</b>	<b>Audio Mixer &gt; Mixer Ducking &gt; Ducking Mode</b>	Select the amount of time (s) between when ducking is triggered to release (level is below the Depth) and the Release is applied. <ol style="list-style-type: none"> <li>1. Click the <b>Change Type</b> button and select whether you want to set (<b>Absolute</b>) or reset (<b>Reset</b>) the parameter. Some selections will not be available when you reset the parameter.</li> <li>2. Enter the new gain value in n the <b>Gain (dB)</b> field.</li> <li>3. Click the <b>InnerAudioMixerChannel</b> button and select the channel you want to send the command to.</li> </ol>
<b>Mix Reduction</b>	<b>Audio Mixer &gt; Mixer Ducking &gt; Ducking Mode</b>	Select the amount of attenuation/gain (dB) that you want to reduce the mix by when the ducking is applied (above threshold). <ol style="list-style-type: none"> <li>1. Click the <b>Change Type</b> button and select whether you want to set (<b>Absolute</b>) or reset (<b>Reset</b>) the parameter. Some selections will not be available when you reset the parameter.</li> <li>2. Enter the new gain value in n the <b>Gain (dB)</b> field.</li> <li>3. Click the <b>InnerAudioMixerChannel</b> button and select the channel you want to send the command to.</li> </ol>
<b>Release</b>	<b>Audio Mixer &gt; Mixer Ducking &gt; Ducking Mode</b>	Select the amount of time (ms) you want to pass after the Hold is applied and the ducking is fully released (mix back to normal levels). <ol style="list-style-type: none"> <li>1. Click the <b>Change Type</b> button and select whether you want to set (<b>Absolute</b>) or reset (<b>Reset</b>) the parameter. Some selections will not be available when you reset the parameter.</li> <li>2. Enter the new gain value in n the <b>Gain (dB)</b> field.</li> <li>3. Click the <b>InnerAudioMixerChannel</b> button and select the channel you want to send the command to.</li> </ol>
<b>Threshold</b>	Select the level (-dB) at which the ducking is applied to the mix. <b>Audio Mixer &gt; Mixer Ducking &gt; Ducking Mode</b>	. <ol style="list-style-type: none"> <li>1. Click the <b>Change Type</b> button and select whether you want to set (<b>Absolute</b>) or reset (<b>Reset</b>) the parameter. Some selections will not be available when you reset the parameter.</li> <li>2. Enter the new gain value in n the <b>Gain (dB)</b> field.</li> <li>3. Click the <b>InnerAudioMixerChannel</b> button and select the channel you want to send the command to.</li> </ol>

### Talkback Events

Event	Location	Description
<b>Attack</b>	<b>Audio Mixer &gt; Mixer Ducking &gt; Ducking Mode</b>	Select the amount of time (ms) you want to pass between when talkback is triggered to apply and the attenuation being fully applied to the mix. <ol style="list-style-type: none"> <li>1. Click the <b>Change Type</b> button and select whether you want to set (<b>Absolute</b>) or reset (<b>Reset</b>) the parameter. Some selections will not be available when you reset the parameter.</li> <li>2. Enter the new gain value in n the <b>Gain (dB)</b> field.</li> <li>3. Click the <b>InnerAudioMixerChannel</b> button and select the channel you want to send the command to.</li> </ol>

Event	Location	Description
Default All Talkback	Audio Mixer > Mixer Ducking > Ducking Mode	Default the talkback for all audio channels. <ol style="list-style-type: none"> <li>1. Click the <b>Change Type</b> button and select whether you want to set (<b>Absolute</b>) or reset (<b>Reset</b>) the parameter. Some selections will not be available when you reset the parameter.</li> <li>2. Enter the new gain value in n the <b>Gain (dB)</b> field.</li> <li>3. Click the <b>InnerAudioMixerChannel</b> button and select the channel you want to send the command to.</li> </ol>
Default Talkback Channel	Audio Mixer > Mixer Ducking > Ducking Mode	Default the talkback for a selected audio channel. <ol style="list-style-type: none"> <li>1. Click the <b>Change Type</b> button and select whether you want to set (<b>Absolute</b>) or reset (<b>Reset</b>) the parameter. Some selections will not be available when you reset the parameter.</li> <li>2. Enter the new gain value in n the <b>Gain (dB)</b> field.</li> <li>3. Click the <b>InnerAudioMixerChannel</b> button and select the channel you want to send the command to.</li> </ol>
Hold	Audio Mixer > Mixer Ducking > Ducking Mode	Select the amount of time (s) between when talkback is released (Talkback button is released) and the Release is applied. <ol style="list-style-type: none"> <li>1. Click the <b>Change Type</b> button and select whether you want to set (<b>Absolute</b>) or reset (<b>Reset</b>) the parameter. Some selections will not be available when you reset the parameter.</li> <li>2. Enter the new gain value in n the <b>Gain (dB)</b> field.</li> <li>3. Click the <b>InnerAudioMixerChannel</b> button and select the channel you want to send the command to.</li> </ol>
Mix Reduction	Audio Mixer > Mixer Ducking > Ducking Mode	Select the amount of attenuation/gain (dB) that you want to reduce the mix by when the talkback is applied (Talkback button held). <ol style="list-style-type: none"> <li>1. Click the <b>Change Type</b> button and select whether you want to set (<b>Absolute</b>) or reset (<b>Reset</b>) the parameter. Some selections will not be available when you reset the parameter.</li> <li>2. Enter the new gain value in n the <b>Gain (dB)</b> field.</li> <li>3. Click the <b>InnerAudioMixerChannel</b> button and select the channel you want to send the command to.</li> </ol>
Release	Audio Mixer > Mixer Ducking > Ducking Mode	Select the amount of time (ms) you want to pass after the Hold is applied and the talkback is fully released (mix back to normal levels). <ol style="list-style-type: none"> <li>1. Click the <b>Change Type</b> button and select whether you want to set (<b>Absolute</b>) or reset (<b>Reset</b>) the parameter. Some selections will not be available when you reset the parameter.</li> <li>2. Enter the new gain value in n the <b>Gain (dB)</b> field.</li> <li>3. Click the <b>InnerAudioMixerChannel</b> button and select the channel you want to send the command to.</li> </ol>
Talkback Mode	Audio Mixer > Mixer Ducking > Ducking Mode	Turn on Talkback for the selected channel. <ol style="list-style-type: none"> <li>1. Click the <b>InnerAudioMixerChannel</b> button and select the channel you want to send the command to.</li> <li>2. Click <b>Talkback Mode</b>.</li> </ol>

## Equalizer Events

Event	Location	Description
Default All EQ	Audio Mixer > Equalizer	Default the equalizer for all audio channels. <ol style="list-style-type: none"> <li>1. Click <b>Default All EQ</b>.</li> </ol>

Event	Location	Description
Default Selected EQ	Audio Mixer > Equalizer	Default the equalizer for a selected audio channel. <ol style="list-style-type: none"> <li>1. Click <b>Default EQ Selection</b>.</li> <li>2. Click the <b>InnerAudioMixerChannel</b> button and select the channel you want to send the command to.</li> </ol>
EQ Bypass	Audio Mixer > Equalizer	Bypass equalizer. <ol style="list-style-type: none"> <li>1. Click <b>Bypass</b>.</li> <li>2. Click the <b>InnerAudioMixerChannel</b> button and select the channel you want to send the command to.</li> <li>3. Click the <b>Change Type</b> button and select whether you want to set (<b>Absolute</b>) or reset (<b>Reset</b>) the parameter. Some selections will not be available when you reset the parameter.</li> <li>4. Click the <b>Value</b> button to turn bypass on (<b>On</b>), or off (<b>Off</b>).</li> </ol>
High Shelf Gain	Audio Mixer > Equalizer	Adjust the gain of the high frequency band. <ol style="list-style-type: none"> <li>1. Click <b>High Shelf 1 Gain</b>.</li> <li>2. Click the <b>Change Type</b> button and select whether you want to set (<b>Absolute</b>) or reset (<b>Reset</b>) the parameter. Some selections will not be available when you reset the parameter.</li> <li>3. Enter the new gain value in n the <b>Gain (dB)</b> field.</li> <li>4. Click the <b>InnerAudioMixerChannel</b> button and select the channel you want to send the command to.</li> </ol>
High Shelf Min Freq	Audio Mixer > Equalizer	Set the high shelf minimum frequency. <ol style="list-style-type: none"> <li>1. Click <b>High Shelf Min Freq</b>.</li> <li>2. Click the <b>Change Type</b> button and select whether you want to set (<b>Absolute</b>) or reset (<b>Reset</b>) the parameter. Some selections will not be available when you reset the parameter.</li> <li>3. In the <b>Frequency (Hz)</b> field, enter the new frequency setting.</li> <li>4. Click the <b>InnerAudioMixerChannel</b> button and select the channel you want to send the command to.</li> </ol>
Low Shelf Gain	Audio Mixer > Equalizer > Low Shelf Gain	Adjust the gain of the low frequency band. <ol style="list-style-type: none"> <li>1. Click the <b>Change Type</b> button and select whether you want to set (<b>Absolute</b>) or reset (<b>Reset</b>) the parameter. Some selections will not be available when you reset the parameter.</li> <li>2. Enter the new gain value in n the <b>Gain (dB)</b> field.</li> <li>3. Click the <b>InnerAudioMixerChannel</b> button and select the channel you want to send the command to.</li> </ol>
Midrange 1 Center Freq	Audio Mixer > Equalizer	Set the midrange 1 center frequency. <ol style="list-style-type: none"> <li>1. Click <b>Midrange 1 Center Freq</b>.</li> <li>2. Click the <b>Change Type</b> button and select whether you want to set (<b>Absolute</b>) or reset (<b>Reset</b>) the parameter. Some selections will not be available when you reset the parameter.</li> <li>3. In the <b>Frequency (Hz)</b> field, enter the new frequency setting.</li> <li>4. Click the <b>InnerAudioMixerChannel</b> button and select the channel you want to send the command to.</li> </ol>
Midrange 1 Gain	Audio Mixer > Equalizer	Adjust the gain of a midrange frequency band. <ol style="list-style-type: none"> <li>1. Click <b>Midrange 1 Gain</b>.</li> <li>2. Click the <b>Change Type</b> button and select whether you want to set (<b>Absolute</b>) or reset (<b>Reset</b>) the parameter. Some selections will not be available when you reset the parameter.</li> <li>3. Enter the new gain value in n the <b>Gain (dB)</b> field.</li> <li>4. Click the <b>InnerAudioMixerChannel</b> button and select the channel you want to send the command to.</li> </ol>

Event	Location	Description
Midrange 1 Q	Audio Mixer > Equalizer	<p>Set the midrange 1 Q.</p> <ol style="list-style-type: none"> <li>1. Click <b>Midrange 1 Q</b>.</li> <li>2. Click the <b>Change Type</b> button and select whether you want to set (<b>Absolute</b>) or reset (<b>Reset</b>) the parameter. Some selections will not be available when you reset the parameter.</li> <li>3. In the <b>Value (%)</b> field, enter the new Q setting.</li> <li>4. Click the <b>InnerAudioMixerChannel</b> button and select the channel you want to send the command to.</li> </ol>
Midrange 2 Center Freq	Audio Mixer > Equalizer	<p>Set the midrange 2 center frequency.</p> <ol style="list-style-type: none"> <li>1. Click <b>Midrange 2 Center Freq</b>.</li> <li>2. Click the <b>Change Type</b> button and select whether you want to set (<b>Absolute</b>) or reset (<b>Reset</b>) the parameter. Some selections will not be available when you reset the parameter.</li> <li>3. In the <b>Frequency (Hz)</b> field, enter the new frequency setting.</li> <li>4. Click the <b>InnerAudioMixerChannel</b> button and select the channel you want to send the command to.</li> </ol>
Midrange 2 Gain	Audio Mixer > Equalizer	<p>Adjust the gain of a midrange frequency band.</p> <ol style="list-style-type: none"> <li>1. Click <b>Midrange 2 Gain</b>.</li> <li>2. Click the <b>Change Type</b> button and select whether you want to set (<b>Absolute</b>) or reset (<b>Reset</b>) the parameter. Some selections will not be available when you reset the parameter.</li> <li>3. Enter the new gain value in n the <b>Gain (dB)</b> field.</li> <li>4. Click the <b>InnerAudioMixerChannel</b> button and select the channel you want to send the command to.</li> </ol>
Midrange 2 Q	Audio Mixer > Equalizer	<p>Set the midrange 2 Q.</p> <ol style="list-style-type: none"> <li>1. Click <b>Midrange 2 Q</b>.</li> <li>2. Click the <b>Change Type</b> button and select whether you want to set (<b>Absolute</b>) or reset (<b>Reset</b>) the parameter. Some selections will not be available when you reset the parameter.</li> <li>3. In the <b>Value (%)</b> field, enter the new Q setting.</li> <li>4. Click the <b>InnerAudioMixerChannel</b> button and select the channel you want to send the command to.</li> </ol>

### Compressor Limiter Events

Event	Location	Description
Attack	Audio Mixer > Compressor Limiter	<p>Set the attack for CL.</p> <ol style="list-style-type: none"> <li>1. Click <b>Attack</b>.</li> <li>2. Click the <b>Change Type</b> button and select whether you want to set (<b>Absolute</b>) or reset (<b>Reset</b>) the parameter. Some selections will not be available when you reset the parameter.</li> <li>3. In the <b>Transition Time (ms)</b> field, enter the new attack time setting.</li> <li>4. Click the <b>InnerAudioMixerChannel</b> button and select the channel you want to send the command to.</li> </ol>

Event	Location	Description
Channel AFV Fade	Audio Mixer > Config	<p>Select whether AFV transitions use a fade or a cut.</p> <ol style="list-style-type: none"> <li>1. Click <b>Channel AFV Fade</b>.</li> <li>2. Click the <b>InnerAudioMixerChannel</b> button and select the channel you want to send the command to.</li> <li>3. Click the <b>Change Type</b> button and select whether you want to set (<b>Absolute</b>) or reset (<b>Reset</b>) the parameter. Some selections will not be available when you reset the parameter.</li> <li>4. Click a <b>Value</b> button to select whether AFV transition use a fade (<b>On</b>) or a cut (<b>Off</b>).</li> </ol>
Channel Position	Audio Mixer > Config	<p>Move a fader stripe left or right on the mix layer in the RAVE audio mixer.</p> <ol style="list-style-type: none"> <li>1. Click <b>Channel Position</b>.</li> <li>2. Click the <b>InnerAudioMixerOutput</b> button and select the mixer output that you want to send the command to.</li> <li>3. Click the <b>InnerAudioMixerChannel</b> button and select the channel you want to send the command to.</li> <li>4. Click an <b>Action</b> button to move the stripe to the left of the layer (<b>Up</b>) or to the right (<b>Down</b>).</li> </ol>
Channel Processing Order (EQ/CL)	Audio Mixer > Config	<p>Select the EQ and CL processing order for specific fader.</p> <ol style="list-style-type: none"> <li>1. Click <b>Channel Processing Order</b>.</li> <li>2. Click the <b>InnerAudioMixerChannel</b> button and select the channel you want to send the command to.</li> <li>3. Click a <b>Component</b> button to select whether you are assigning the order for the EQ (<b>EQ</b>) or CL (<b>CL</b>).</li> <li>4. Click a <b>Position</b> button to select whether the EQ or CL processing is applied first (<b>1</b>) or last (<b>2</b>).</li> </ol>
Channel Visible	Audio Mixer > Config	<p>Select whether AFV transitions use a fade or a cut.</p> <ol style="list-style-type: none"> <li>1. Click <b>Channel Visible</b>.</li> <li>2. Click the <b>InnerAudioMixerOutput</b> button and select the mixer output that you want to send the command to.</li> <li>3. Click the <b>InnerAudioMixerChannel</b> button and select the channel you want to send the command to.</li> <li>4. Click the <b>Change Type</b> button and select whether you want to set (<b>Absolute</b>) or reset (<b>Reset</b>) the parameter. Some selections will not be available when you reset the parameter.</li> <li>5. Click a <b>Value</b> button to select whether the selected fader is visible on the mixer (<b>On</b>) or a not (<b>Off</b>).</li> </ol>
CL Bypass	Audio Mixer > Compressor Limiter	<p>Bypass CL.</p> <ol style="list-style-type: none"> <li>1. Click <b>Bypass</b>.</li> <li>2. Click the <b>InnerAudioMixerChannel</b> button and select the channel you want to send the command to.</li> <li>3. Click the <b>Change Type</b> button and select whether you want to set (<b>Absolute</b>) or reset (<b>Reset</b>) the parameter. Some selections will not be available when you reset the parameter.</li> <li>4. Click the <b>Value</b> button to turn bypass on (<b>On</b>), or off (<b>Off</b>).</li> </ol>
Clear PFL	Audio Mixer > Output	<p>Clear Pre Fader Listen (PFL).</p> <ol style="list-style-type: none"> <li>1. Click <b>Clear PFL</b>.</li> </ol>
Clear Solo	Audio Mixer > Output	<p>Clear solo for an output.</p> <ol style="list-style-type: none"> <li>1. Click <b>Clear Solo</b>.</li> <li>2. Click the <b>InnerAudioMixerOutput</b> button and select the mixer output that you want to send the command to.</li> </ol>

Event	Location	Description
Compression	Audio Mixer > Compressor Limiter	Set the compression ratio for CL. <ol style="list-style-type: none"> <li>1. Click <b>Compression</b>.</li> <li>2. Click the <b>Change Type</b> button and select whether you want to set (<b>Absolute</b>) or reset (<b>Reset</b>) the parameter. Some selections will not be available when you reset the parameter.</li> <li>3. In the <b>Ratio (:1)</b> field, enter the new ratio for the compression setting.</li> <li>4. Click the <b>InnerAudioMixerChannel</b> button and select the channel you want to send the command to.</li> </ol>
Default All CL	Audio Mixer > Compressor Limiter	Default All CL setting. <ol style="list-style-type: none"> <li>1. Click <b>Default All CL</b>.</li> </ol>
Default Selected CL	Audio Mixer > Compressor Limiter	Default CL settings. <ol style="list-style-type: none"> <li>1. Click <b>Default CL Selection</b>.</li> <li>2. Click the <b>InnerAudioMixerChannel</b> button and select the channel you want to send the command to.</li> </ol>
Makeup	Audio Mixer > Compressor Limiter	Set the makeup level for CL. <ol style="list-style-type: none"> <li>1. Click <b>Makeup</b>.</li> <li>2. Click the <b>Change Type</b> button and select whether you want to set (<b>Absolute</b>) or reset (<b>Reset</b>) the parameter. Some selections will not be available when you reset the parameter.</li> <li>3. Enter the new gain value in the <b>Gain (dB)</b> field.</li> <li>4. Click the <b>InnerAudioMixerChannel</b> button and select the channel you want to send the command to.</li> </ol>
Output Volume	Audio Mixer > Output	Set the output volume. <ol style="list-style-type: none"> <li>1. Click <b>Volume</b>.</li> <li>2. Click the <b>InnerAudioMixerOutput</b> button and select the mixer output that you want to send the command to.</li> <li>3. Click the <b>Change Type</b> button and select whether you want to set (<b>Absolute</b>) or reset (<b>Reset</b>) the parameter. Some selections will not be available when you reset the parameter.</li> <li>4. In the <b>Volume (dB)</b> field, enter the level you want to set.</li> </ol>
Pad	Audio Mixer > PreAmp	Turn pad power on or off on a ABM. <ol style="list-style-type: none"> <li>1. Click <b>Pad</b>.</li> <li>2. Click the <b>InnerAudioMixerAnalogInput</b> button and select the analog input you want to send the command to.</li> <li>3. Click the <b>Change Type</b> button and select whether you want to set (<b>Absolute</b>) or reset (<b>Reset</b>) the parameter. Some selections will not be available when you reset the parameter.</li> <li>4. Click the <b>Value</b> button to turn pad on (<b>On</b>), or off (<b>Off</b>).</li> </ol>
Phantom Power	Audio Mixer > PreAmp	Turn phantom power on or off on a ABM. <ol style="list-style-type: none"> <li>1. Click <b>Phantom Power</b>.</li> <li>2. Click the <b>InnerAudioMixerAnalogInput</b> button and select the analog input you want to send the command to.</li> <li>3. Click the <b>Change Type</b> button and select whether you want to set (<b>Absolute</b>) or reset (<b>Reset</b>) the parameter. Some selections will not be available when you reset the parameter.</li> <li>4. Click the <b>Value</b> button to turn phantom power on (<b>On</b>), or off (<b>Off</b>).</li> </ol>

Event	Location	Description
<b>Pre-Amp Gain</b>	<b>Audio Mixer &gt; PreAmp</b>	<p>Set the pre-amp gain on a ABM analog input.</p> <ol style="list-style-type: none"> <li>1. Click <b>Gain</b>.</li> <li>2. Click the <b>InnerAudioMixerAnalogInput</b> button and select the analog input you want to send the command to.</li> <li>3. Click the <b>Change Type</b> button and select whether you want to set (<b>Absolute</b>) or reset (<b>Reset</b>) the parameter. Some selections will not be available when you reset the parameter.</li> <li>4. Enter the new gain value in n the <b>Gain (dB)</b> field.</li> </ol>
<b>Processing Order (EQ/CL)</b>	<b>Audio Mixer &gt; Config</b>	<p>Select the EQ and CL processing order for all faders.</p> <ol style="list-style-type: none"> <li>1. Click <b>Processing Order</b>.</li> <li>2. Click a <b>Component</b> button to select whether you are assigning the order for the EQ (<b>EQ</b>) or CL (<b>CL</b>).</li> <li>3. Click a <b>Position</b> button to select whether the EQ or CL processing is applied first (<b>1</b>) or last (<b>2</b>).</li> </ol>
<b>Release</b>	<b>Audio Mixer &gt; Compressor Limiter</b>	<p>Set the release for CL.</p> <ol style="list-style-type: none"> <li>1. Click <b>Release</b>.</li> <li>2. Click the <b>Change Type</b> button and select whether you want to set (<b>Absolute</b>) or reset (<b>Reset</b>) the parameter. Some selections will not be available when you reset the parameter.</li> <li>3. In the <b>Transition Time (ms)</b> field, enter the new release time setting.</li> <li>4. Click the <b>InnerAudioMixerChannel</b> button and select the channel you want to send the command to.</li> </ol>
<b>Source AFV Input</b>	<b>Audio Mixer &gt; Config</b>	<p>Select the video source that you want a fader to follow.</p> <ol style="list-style-type: none"> <li>1. Click <b>Source AFV Input</b>.</li> <li>2. Click the <b>InnerAudioMixerChannel</b> button and select the channel you want to send the command to.</li> <li>3. Click the <b>Value</b> button and select the video source that you want the audio fader to follow.</li> </ol>
<b>Source Audio Channel</b>		<p>Select the audio channels to be assigned to a fader.</p> <ol style="list-style-type: none"> <li>1. Click <b>Source Audio Channel</b>.</li> <li>2. Click the <b>InnerAudioMixerChannel</b> button and select the channel you want to send the command to.</li> <li>3. Click the <b>Value</b> button and select the channels you want to assign to the fader.</li> </ol>
<b>Source Audio Input</b>	<b>Audio Mixer &gt; Config</b>	<p>Select the audio source to be assigned to a fader.</p> <ol style="list-style-type: none"> <li>1. Click <b>Source Audio Input</b>.</li> <li>2. Click the <b>InnerAudioMixerChannel</b> button and select the channel you want to send the command to.</li> <li>3. Click the <b>Value</b> button and select the audio source you want assigned to the fader.</li> </ol>
<b>Threshold Control</b>	<b>Audio Mixer &gt; Compressor Limiter</b>	<p>Set the threshold control for CL.</p> <ol style="list-style-type: none"> <li>1. Click <b>Threshold Control</b>.</li> <li>2. Click the <b>Change Type</b> button and select whether you want to set (<b>Absolute</b>) or reset (<b>Reset</b>) the parameter. Some selections will not be available when you reset the parameter.</li> <li>3. Enter the new gain value in n the <b>Gain (dB)</b> field.</li> <li>4. Click the <b>InnerAudioMixerChannel</b> button and select the channel you want to send the command to.</li> </ol>



Event	Location	Description
<b>Video Out Audio Mix</b>	<b>Audio Mixer &gt; Output</b>	Set what audio is embedded in an video output. <ol style="list-style-type: none"> <li>1. Click <b>Video Out Audio Mix</b>.</li> <li>2. Click the <b>Output</b> button and select video output that you want to set up.</li> <li>3. Click a <b>Value</b> button to select which audio is embedded in the selected output video stream.</li> </ol>
<b>Video Out Custom Audio Mix</b>	<b>Audio Mixer &gt; Output</b>	Set what audio is embedded in an video output. <ol style="list-style-type: none"> <li>1. Click <b>Video Out Custom Audio Mix</b>.</li> <li>2. Click the <b>Output</b> button and select video output that you want to set up.</li> <li>3. Click the <b>Channel</b> button and select the stereo pair that you want to embed audio on.</li> <li>4. Click the <b>Audio Mix</b> button and select the mix that you want to embed on the selected channels.</li> </ol>

### Output Audio Events

Event	Location	Description
<b>ABM Input Delay</b>	<b>Audio Mixer &gt; ABM Input &gt; Delay</b>	Add a delay to the audio inputs on the ABM. <ol style="list-style-type: none"> <li>1. Click <b>Pad</b>.</li> <li>2. Click the <b>InnerAudioMixerAnalogInput</b> button and select the analog input you want to send the command to.</li> <li>3. Click the <b>Change Type</b> button and select whether you want to set (<b>Absolute</b>) or reset (<b>Reset</b>) the parameter. Some selections will not be available when you reset the parameter.</li> <li>4. Enter the amount of delay (0-13) in the <b>Value</b> field.</li> </ol>
<b>Clear PFL</b>	<b>Audio Mixer &gt; Output &gt; Clear PFL</b>	Clear Pre Fader Listen (PFL).
<b>Clear Solo</b>	<b>Audio Mixer &gt; Output &gt; Clear Solo</b>	Clear solo for an output. <ol style="list-style-type: none"> <li>1. Click the <b>InnerAudioMixerOutput</b> button and select the mixer output that you want to send the command to.</li> </ol>
<b>Output Volume</b>	<b>Audio Mixer &gt; Output &gt; Volume</b>	Set the output volume. <ol style="list-style-type: none"> <li>1. Click the <b>InnerAudioMixerOutput</b> button and select the mixer output that you want to send the command to.</li> <li>2. Click the <b>Change Type</b> button and select whether you want to set (<b>Absolute</b>) or reset (<b>Reset</b>) the parameter. Some selections will not be available when you reset the parameter.</li> <li>3. In the <b>Volume (dB)</b> field, enter the level you want to set.</li> </ol>
<b>Pad</b>	<b>Audio Mixer &gt; PreAmp</b>	Turn pad power on or off on a ABM. <ol style="list-style-type: none"> <li>1. Click <b>Pad</b>.</li> <li>2. Click the <b>InnerAudioMixerAnalogInput</b> button and select the analog input you want to send the command to.</li> <li>3. Click the <b>Change Type</b> button and select whether you want to set (<b>Absolute</b>) or reset (<b>Reset</b>) the parameter. Some selections will not be available when you reset the parameter.</li> <li>4. Click the <b>Value</b> button to turn pad on (<b>On</b>), or off (<b>Off</b>).</li> </ol>

Event	Location	Description
<b>Phantom Power</b>	<b>Audio Mixer &gt; PreAmp</b>	Turn phantom power on or off on a ABM. <ol style="list-style-type: none"> <li>1. Click <b>Phantom Power</b>.</li> <li>2. Click the <b>InnerAudioMixerAnalogInput</b> button and select the analog input you want to send the command to.</li> <li>3. Click the <b>Change Type</b> button and select whether you want to set <b>(Absolute)</b> or reset <b>(Reset)</b> the parameter. Some selections will not be available when you reset the parameter.</li> <li>4. Click the <b>Value</b> button to turn phantom power on <b>(On)</b>, or off <b>(Off)</b>.</li> </ol>
<b>Pre-Amp Gain</b>	<b>Audio Mixer &gt; PreAmp</b>	Set the pre-amp gain on a ABM analog input. <ol style="list-style-type: none"> <li>1. Click <b>Gain</b>.</li> <li>2. Click the <b>InnerAudioMixerAnalogInput</b> button and select the analog input you want to send the command to.</li> <li>3. Click the <b>Change Type</b> button and select whether you want to set <b>(Absolute)</b> or reset <b>(Reset)</b> the parameter. Some selections will not be available when you reset the parameter.</li> <li>4. Enter the new gain value in n the <b>Gain (dB)</b> field.</li> </ol>
<b>Video Out Audio Mix</b>	<b>Audio Mixer &gt; Output &gt; Video Out Audio Mix</b>	Set what audio is embedded in an video output. <ol style="list-style-type: none"> <li>1. Click the <b>Output</b> button and select video output that you want to set up.</li> <li>2. Click a <b>Value</b> button to select which audio is embedded in the selected output video stream.</li> </ol>
<b>Video Out Custom Audio Mix</b>	<b>Audio Mixer &gt; Output &gt; Video Out Custom Audio Mix</b>	Set what audio is embedded in an video output. <ol style="list-style-type: none"> <li>1. Click the <b>Output</b> button and select video output that you want to set up.</li> <li>2. Click the <b>Channel</b> button and select the stereo pair that you want to embed audio on.</li> <li>3. Click the <b>Audio Mix</b> button and select the mix that you want to embed on the selected channels.</li> </ol>

### Configuration Audio Events

Event	Location	Description
<b>Channel AFV Fade</b>	<b>Audio Mixer &gt; Config &gt; Channel AFV Fade</b>	Select whether AFV transitions use a fade or a cut. <ol style="list-style-type: none"> <li>1. Click the <b>InnerAudioMixerChannel</b> button and select the channel you want to send the command to.</li> <li>2. Click the <b>Change Type</b> button and select whether you want to set <b>(Absolute)</b> or reset <b>(Reset)</b> the parameter. Some selections will not be available when you reset the parameter.</li> <li>3. Click a <b>Value</b> button to select whether AFV transition use a fade <b>(On)</b> or a cut <b>(Off)</b>.</li> </ol>
<b>Channel Position</b>	<b>Audio Mixer &gt; Config &gt; Channel Position</b>	Move a fader stripe left or right on the mix layer in the RAVE audio mixer. <ol style="list-style-type: none"> <li>1. Click the <b>InnerAudioMixerOutput</b> button and select the mixer output that you want to send the command to.</li> <li>2. Click the <b>InnerAudioMixerChannel</b> button and select the channel you want to send the command to.</li> <li>3. Click an <b>Action</b> button to move the stripe to the left of the layer <b>(Up)</b> or to the right <b>(Down)</b>.</li> </ol>
<b>Channel Processing Order (EQ/CL)</b>	<b>Audio Mixer &gt; Config &gt; Processing Order</b>	Select the EQ and CL processing order for specific fader. <ol style="list-style-type: none"> <li>1. Click the <b>InnerAudioMixerChannel</b> button and select the channel you want to send the command to.</li> <li>2. Click a <b>Component</b> button to select whether you are assigning the order for the EQ <b>(EQ)</b> or CL <b>(CL)</b>.</li> <li>3. Click a <b>Position</b> button to select whether the EQ or CL processing is applied first <b>(1)</b> or last <b>(2)</b>.</li> </ol>

Event	Location	Description
Channel Visible	Audio Mixer > Config > Channel Visible	Select whether AFV transitions use a fade or a cut. <ol style="list-style-type: none"> <li>1. Click the <b>InnerAudioMixerOutput</b> button and select the mixer output that you want to send the command to.</li> <li>2. Click the <b>InnerAudioMixerChannel</b> button and select the channel you want to send the command to.</li> <li>3. Click the <b>Change Type</b> button and select whether you want to set (<b>Absolute</b>) or reset (<b>Reset</b>) the parameter. Some selections will not be available when you reset the parameter.</li> <li>4. Click a <b>Value</b> button to select whether the selected fader is visible on the mixer (<b>On</b>) or a not (<b>Off</b>).</li> </ol>
Processing Order (EQ/CL)	Audio Mixer > Config > Channel Processing Order	Select the EQ and CL processing order for all faders. <ol style="list-style-type: none"> <li>1. Click a <b>Component</b> button to select whether you are assigning the order for the EQ (<b>EQ</b>) or CL (<b>CL</b>).</li> <li>2. Click a <b>Position</b> button to select whether the EQ or CL processing is applied first (<b>1</b>) or last (<b>2</b>).</li> </ol>
Source AFV Input	Audio Mixer > Config > Source AVF Input	Select the video source that you want a fader to follow. <ol style="list-style-type: none"> <li>1. Click the <b>InnerAudioMixerChannel</b> button and select the channel you want to send the command to.</li> <li>2. Click the <b>Value</b> button and select the video source that you want the audio fader to follow.</li> </ol>
Source Audio Channel	Audio Mixer > Config > Source Audio Channel	Select the audio channels to be assigned to a fader. <ol style="list-style-type: none"> <li>1. Click the <b>InnerAudioMixerChannel</b> button and select the channel you want to send the command to.</li> <li>2. Click the <b>Value</b> button and select the channels you want to assign to the fader.</li> </ol>
Source Audio Input	Audio Mixer > Config > Source Audio Input	Select the audio source to be assigned to a fader. <ol style="list-style-type: none"> <li>1. Click the <b>InnerAudioMixerChannel</b> button and select the channel you want to send the command to.</li> <li>2. Click the <b>Value</b> button and select the audio source you want assigned to the fader.</li> </ol>
Test Tone Frequency	Audio Mixer > Config > Test Tone Frequency	Select the test tone frequency for the selected audio channel. <ol style="list-style-type: none"> <li>1. Click the <b>InnerAudioMixerChannel</b> button and select the channel you want to send the command to.</li> <li>2. Click the <b>Frequency (Hz)</b> button and select the audio frequency you want to use for the test tone.</li> </ol>

## Device Custom Controls

### Audio Mixer (Device)

Event	Location	Description
Audio Mixer Pan	Devices > Audio Mixer	Set the pan level for the selected channel on the selected device. <ol style="list-style-type: none"> <li>1. Click <b>Audio Pan</b>.</li> <li>2. Click the <b>Audio Mixer</b> button and select the device you want to send the command to.</li> <li>3. Click the <b>Channel</b> button and select the channel you want to send the command to.</li> <li>4. Click the <b>Change Type</b> button and select whether you want to set (<b>Absolute</b>) or reset (<b>Reset</b>) the parameter. Some selections will not be available when you reset the parameter.</li> <li>5. Enter the new pan level in the <b>Pan Left/Right (%)</b> field.</li> </ol>

Event	Location	Description
<b>Audio Mixer Volume</b>	<b>Devices &gt; Audio Mixer</b>	<p>Set the level for the selected channel on the selected device.</p> <ol style="list-style-type: none"> <li>1. Click <b>Audio Volume</b>.</li> <li>2. Click the <b>Audio Mixer</b> button and select the device you want to send the command to.</li> <li>3. Click the <b>Channel</b> button and select the channel you want to send the command to.</li> <li>4. Click the <b>Change Type</b> button and select whether you want to set <b>(Absolute)</b> or reset <b>(Reset)</b> the parameter. Some selections will not be available when you reset the parameter.</li> <li>5. Enter the new audio level in the <b>Volume (%)</b> field.</li> </ol>

## Camera

Event	Location	Description
<b>Robotic Camera — Halt All</b>	<b>Devices &gt; Camera</b>	<p>Send the halt command to the selected camera.</p> <ol style="list-style-type: none"> <li>1. Click <b>Camera Halt All</b>.</li> <li>2. Click the <b>Camera</b> button and select the device you want to send the command to.</li> </ol>
<b>Robotic Camera — Recall Shot</b>	<b>Devices &gt; Camera</b>	<p>Recall a shot on the selected camera at the rate/speed set in the shot.</p> <ol style="list-style-type: none"> <li>1. Click <b>Recall Shot</b>.</li> <li>2. Click the <b>Camera</b> button and select the device you want to send the command to.</li> <li>3. Click the <b>Channel</b> button and select the channel you want to send the command to.</li> <li>4. Click the <b>Change Type</b> button and select whether you want to set <b>(Absolute)</b> or reset <b>(Reset)</b> the parameter. Some selections will not be available when you reset the parameter.</li> <li>5. Enter the shot number you want to recall from in the <b>Shot</b> field.</li> </ol>
<b>Robotic Camera — Recall Shot Fast</b>	<b>Devices &gt; Camera</b>	<p>Recall a shot on the selected camera as quickly as possible.</p> <ol style="list-style-type: none"> <li>1. Click <b>Recall Shot (Fast)</b>.</li> <li>2. Click the <b>Camera</b> button and select the device you want to send the command to.</li> <li>3. Click the <b>Channel</b> button and select the channel you want to send the command to.</li> <li>4. Click the <b>Change Type</b> button and select whether you want to set <b>(Absolute)</b> or reset <b>(Reset)</b> the parameter. Some selections will not be available when you reset the parameter.</li> <li>5. Enter the shot number you want to recall from in the <b>Shot</b> field.</li> </ol>
<b>Robotic Camera — Store Shot</b>	<b>Devices &gt; Camera</b>	<p>Store a shot on the selected camera.</p> <ol style="list-style-type: none"> <li>1. Click <b>Store Shot</b>.</li> <li>2. Click the <b>Camera</b> button and select the device you want to send the command to.</li> <li>3. Click the <b>Channel</b> button and select the channel you want to send the command to.</li> <li>4. Click the <b>Change Type</b> button and select whether you want to set <b>(Absolute)</b> or reset <b>(Reset)</b> the parameter. Some selections will not be available when you reset the parameter.</li> <li>5. Enter the shot number you want to store to in the <b>Shot</b> field.</li> </ol>

## GPI

Event	Location	Description
<b>GPI Output — Edge Trigger Setup</b>	<b>Devices &gt; GPO</b>	<p>Set up the type of edge trigger for the GPI output.</p> <ol style="list-style-type: none"> <li>1. Click <b>GPO Edge Duration</b></li> <li>2. Click the <b>GPO</b> button and select the GPI output that you want to configure.</li> <li>3. Click the <b>Change Type</b> button and select whether you want to set (<b>Absolute</b>) or reset (<b>Reset</b>) the parameter. Some selections will not be available when you reset the parameter.</li> <li>4. Enter the duration of the edge trigger in the <b>Duration (fr)</b> field.</li> </ol>
<b>GPI Output — Level Trigger Setup</b>	<b>Devices &gt; GPO</b>	<p>Set up the type of level trigger for the GPI output.</p> <ol style="list-style-type: none"> <li>1. Click <b>GPO Level Config</b></li> <li>2. Click the <b>GPO</b> button and select the GPI output that you want to configure.</li> <li>3. Click a <b>Level</b> to select whether the level trigger uses a high (<b>High</b>) or low (<b>Low</b>) level trigger.</li> </ol>
<b>GPI Output — Mode</b>	<b>Devices &gt; GPO</b>	<p>Select whether the level trigger GPI output act as a tally.</p> <ol style="list-style-type: none"> <li>1. Click <b>GPO Mode</b></li> <li>2. Click the <b>GPO</b> button and select the GPI output that you want to configure.</li> <li>3. Click a <b>Mode</b> button to select whether the level trigger GPI output, when assigned to video source, acts as a roll clip (<b>Normal</b>) or as a tally (<b>Tally</b>) for the selected source.</li> </ol>
<b>GPI Output — Trigger</b>	<b>Devices &gt; GPO</b>	<p>Trigger a GPI output.</p> <ol style="list-style-type: none"> <li>1. Click <b>GPO Trigger</b></li> <li>2. Click the <b>GPO</b> button and select the GPI output that you want to trigger.</li> </ol>
<b>GPI Output — Trigger Type</b>	<b>Devices &gt; GPO</b>	<p>Select the type of trigger for the GPI output.</p> <ol style="list-style-type: none"> <li>1. Click <b>GPO Trigger Configuration</b></li> <li>2. Click the <b>GPO</b> button and select the GPI output that you want to configure.</li> <li>3. Click a <b>Trigger</b> to select whether the GPI output uses a level (<b>Level</b>) or edge (<b>Edge</b>) trigger.</li> </ol>

## PBus II

Event	Location	Description
<b>PBus — Recall</b>	<b>Devices &gt; PBus</b>	<p>Recall a register on the selected PBus device.</p> <ol style="list-style-type: none"> <li>1. Click <b>PBus Recall Register</b>.</li> <li>2. Click the <b>PBus</b> button and select the device you want to send the command to.</li> <li>3. Click the <b>Device</b> button and select the channel you want to send the command to.</li> <li>4. Click the <b>Change Type</b> button and select whether you want to set (<b>Absolute</b>) or reset (<b>Reset</b>) the parameter. Some selections will not be available when you reset the parameter.</li> <li>5. Enter number of the register you want to recall in the <b>Register</b> field.</li> </ol>

Event	Location	Description
<b>PBus — Trigger</b>	<b>Devices &gt; PBus</b>	<p>Trigger a function on the selected PBus device.</p> <ol style="list-style-type: none"> <li>1. Click <b>PBus Trigger Function</b>.</li> <li>2. Click the <b>PBus</b> button and select the device you want to send the command to.</li> <li>3. Click the <b>Device</b> button and select the channel you want to send the command to.</li> <li>4. Click the <b>Change Type</b> button and select whether you want to set <b>(Absolute)</b> or reset <b>(Reset)</b> the parameter. Some selections will not be available when you reset the parameter.</li> <li>5. Enter the number of the function you want to trigger in the <b>Function</b> field.</li> </ol>

## RossTalk

*Table 16: RossTalk (XPression)*

Event	Location	Description
<b>RossTalk CC</b>	<b>Devices &gt; RossTalk (XPression) &gt; CC</b>	<p>Send the simulated custom control to the selected device.</p> <ol style="list-style-type: none"> <li>1. Click the <b>RossTalk Device</b> button and select the device you want to send the RossTalk command to.</li> <li>2. Enter the bank of the custom control in the <b>Bank</b> field.</li> <li>3. Enter the number of the custom control in the <b>Custom</b> field.</li> </ol>
<b>RossTalk Clear All</b>	<b>Devices &gt; RossTalk (XPression) &gt; Clear All</b>	<p>Send the Clear All command to the selected device.</p> <ol style="list-style-type: none"> <li>1. Click the <b>RossTalk Device</b> button and select the device you want to send the RossTalk command to.</li> </ol>
<b>RossTalk Clear Channel</b>	<b>Devices &gt; RossTalk (XPression) &gt; Clear Channel</b>	<p>Send the Clear Framebuffer command to the selected device.</p> <ol style="list-style-type: none"> <li>1. Click the <b>RossTalk Device</b> button and select the device you want to send the RossTalk command to.</li> <li>2. Enter the framebuffer that you want to perform the action on in the <b>Channel</b> field.</li> </ol>
<b>RossTalk Clear Layer</b>	<b>Devices &gt; RossTalk (XPression) &gt; Clear Layer</b>	<p>Send the Clear Framebuffer command for a framebuffer and layer to the selected device.</p> <ol style="list-style-type: none"> <li>1. Click the <b>RossTalk Device</b> button and select the device you want to send the RossTalk command to.</li> <li>2. Enter the framebuffer that you want to perform the action on in the <b>Channel</b> field.</li> <li>3. Enter the layer that you want to perform the action on in the <b>Layer</b> field.</li> </ol>
<b>RossTalk — Cue Channel</b>	<b>Devices &gt; RossTalk (XPression) &gt; Cue (2)</b>	<p>Send the Cue command for a specific item and framebuffer to the selected device.</p> <ol style="list-style-type: none"> <li>1. Click the <b>RossTalk Device</b> button and select the device you want to send the RossTalk command to.</li> <li>2. Enter the take item id of the item you want to perform the action on in the <b>Take ID</b> field.</li> <li>3. Enter the framebuffer that you want to perform the action on in the <b>Channel</b> field.</li> </ol>
<b>RossTalk — Cue Current</b>	<b>Devices &gt; RossTalk (XPression) &gt; Cue</b>	<p>Send the Cue command to the selected device.</p> <ol style="list-style-type: none"> <li>1. Click the <b>RossTalk Device</b> button and select the device you want to send the RossTalk command to.</li> </ol>

Event	Location	Description
RossTalk — Cue Item	Devices > RossTalk (XPression) > Cue (1)	Send the Cue command for a specific item to the selected device. <ol style="list-style-type: none"> <li>1. Click the <b>RossTalk Device</b> button and select the device you want to send the RossTalk command to.</li> <li>2. Enter the take item id of the item you want to perform the action on in the <b>Take ID</b> field.</li> </ol>
RossTalk — Cue Layer	Devices > RossTalk (XPression) > Cue (3)	Send the Cue command for a specific item and location to the selected device. <ol style="list-style-type: none"> <li>1. Click the <b>RossTalk Device</b> button and select the device you want to send the RossTalk command to.</li> <li>2. Enter the take item id of the item you want to perform the action on in the <b>Take ID</b> field.</li> <li>3. Enter the framebuffer that you want to perform the action on in the <b>Channel</b> field.</li> <li>4. Enter the layer that you want to perform the action on in the <b>Layer</b> field.</li> </ol>
RossTalk Custom Command	Devices > RossTalk (XPression) > RossTalk Custom Cmd(CRLF)	Send a manual RossTalk string to XPression. Each string has CRLF (carriage return line feed) appended to the end. <ol style="list-style-type: none"> <li>1. Click the <b>RossTalk Device</b> button and select the device you want to send the RossTalk command to.</li> <li>2. Enter the RossTalk string in the <b>Custom Cmd</b> field.</li> </ol>
RossTalk — Focus	Devices > RossTalk (XPression) > Focus	Send the Focus command for a specific item to the selected device. <ol style="list-style-type: none"> <li>1. Click the <b>RossTalk Device</b> button and select the device you want to send the RossTalk command to.</li> <li>2. Enter the take item id of the item you want to perform the action on in the <b>Take ID</b> field.</li> </ol>
RossTalk — GPI	Devices > RossTalk (XPression) > GPI	Send the simulated GPI input to the selected device. <ol style="list-style-type: none"> <li>1. Click the <b>RossTalk Device</b> button and select the device you want to send the RossTalk command to.</li> <li>2. Enter the GPI you want to simulate triggering in the <b>GPI</b> field.</li> </ol>
RossTalk — Layer Off	Devices > RossTalk (XPression) > layer Off	Send the Layer Off command for a specific framebuffer and layer to the selected device. <ol style="list-style-type: none"> <li>1. Click the <b>RossTalk Device</b> button and select the device you want to send the RossTalk command to.</li> <li>2. Enter the framebuffer that you want to perform the action on in the <b>Channel</b> field.</li> <li>3. Enter the layer that you want to perform the action on in the <b>Layer</b> field.</li> </ol>
RossTalk — Next	Devices > RossTalk (XPression) > Next	Send the Next command to the selected device. <ol style="list-style-type: none"> <li>1. Click the <b>RossTalk Device</b> button and select the device you want to send the RossTalk command to.</li> </ol>
RossTalk — Read Current	Devices > RossTalk (XPression) > Read	Send the Read command to the selected device. <ol style="list-style-type: none"> <li>1. Click the <b>RossTalk Device</b> button and select the device you want to send the RossTalk command to.</li> </ol>
RossTalk — Read Item	Devices > RossTalk (XPression) > Read (1)	Send the Read command for a specific item to the selected device. <ol style="list-style-type: none"> <li>1. Click the <b>RossTalk Device</b> button and select the device you want to send the RossTalk command to.</li> <li>2. Enter the take item id of the item you want to perform the action on in the <b>Take ID</b> field.</li> </ol>
RossTalk — Read Layer	Devices > RossTalk (XPression) > Read (2)	Send the Read command for a specific item and layer to the selected device. <ol style="list-style-type: none"> <li>1. Click the <b>RossTalk Device</b> button and select the device you want to send the RossTalk command to.</li> <li>2. Enter the take item id of the item you want to perform the action on in the <b>Take ID</b> field.</li> <li>3. Enter the layer that you want to perform the action on in the <b>Layer</b> field.</li> </ol>

Event	Location	Description
RossTalk — Resume Channel	Devices > RossTalk (XPression) > Resume Channel	Send the Resume command for a framebuffer to the selected device. <ol style="list-style-type: none"> <li>1. Click the <b>RossTalk Device</b> button and select the device you want to send the RossTalk command to.</li> <li>2. Enter the framebuffer that you want to perform the action on in the <b>Channel</b> field.</li> </ol>
RossTalk — Resume Layer	Devices > RossTalk (XPression) > Resume Layer	Send the Resume command for a framebuffer and layer to the selected device. <ol style="list-style-type: none"> <li>1. Click the <b>RossTalk Device</b> button and select the device you want to send the RossTalk command to.</li> <li>2. Enter the framebuffer that you want to perform the action on in the <b>Channel</b> field.</li> <li>3. Enter the layer that you want to perform the action on in the <b>Layer</b> field.</li> </ol>
RossTalk — Sequencer Down	Devices > RossTalk (XPression) > Sequencer Down	Send the Sequencer Down command to the selected device. <ol style="list-style-type: none"> <li>1. Click the <b>RossTalk Device</b> button and select the device you want to send the RossTalk command to.</li> </ol>
RossTalk — Sequencer Up	Devices > RossTalk (XPression) > Sequencer Up	Send the Sequencer Up command to the selected device. <ol style="list-style-type: none"> <li>1. Click the <b>RossTalk Device</b> button and select the device you want to send the RossTalk command to.</li> </ol>
RossTalk — Swap Channel	Devices > RossTalk (XPression) > Swap (1)	Send the Swap command for a specific framebuffer to the selected device. <ol style="list-style-type: none"> <li>1. Click the <b>RossTalk Device</b> button and select the device you want to send the RossTalk command to.</li> <li>2. Enter the framebuffer that you want to perform the action on in the <b>Channel</b> field.</li> </ol>
RossTalk — Swap Current	Devices > RossTalk (XPression) > Swap	Send the Swap command to the selected device. <ol style="list-style-type: none"> <li>1. Click the <b>RossTalk Device</b> button and select the device you want to send the RossTalk command to.</li> </ol>
RossTalk — Swap Layer	Devices > RossTalk (XPression) > Swap (2)	Send the Swap command for a specific framebuffer and layer to the selected device. <ol style="list-style-type: none"> <li>1. Click the <b>RossTalk Device</b> button and select the device you want to send the RossTalk command to.</li> <li>2. Enter the framebuffer that you want to perform the action on in the <b>Channel</b> field.</li> <li>3. Enter the layer that you want to perform the action on in the <b>Layer</b> field.</li> </ol>
RossTalk — Take Channel	Devices > RossTalk (XPression) > Take (2)	Send the Take command for a specific item and framebuffer to the selected device. <ol style="list-style-type: none"> <li>1. Click the <b>RossTalk Device</b> button and select the device you want to send the RossTalk command to.</li> <li>2. Enter the take item id of the item you want to perform the action on in the <b>Take ID</b> field.</li> <li>3. Enter the framebuffer that you want to perform the action on in the <b>Channel</b> field.</li> </ol>
RossTalk — Take Item	Devices > RossTalk (XPression) > Take (1)	Send the Take command for a specific item to the selected device. <ol style="list-style-type: none"> <li>1. Click the <b>RossTalk Device</b> button and select the device you want to send the RossTalk command to.</li> <li>2. Enter the take item id of the item you want to perform the action on in the <b>Take ID</b> field.</li> </ol>



Event	Location	Description
RossTalk — Take Layer	Devices > RossTalk (XPression) > Take (3)	Send the Take command for a specific item and location to the selected device. <ol style="list-style-type: none"> <li>1. Click the <b>RossTalk Device</b> button and select the device you want to send the RossTalk command to.</li> <li>2. Enter the take item id of the item you want to perform the action on in the <b>Take ID</b> field.</li> <li>3. Enter the framebuffer that you want to perform the action on in the <b>Channel</b> field.</li> <li>4. Enter the layer that you want to perform the action on in the <b>Layer</b> field.</li> </ol>
RossTalk — Take Offline	Devices > RossTalk (XPression) > Take Offline	Send the Take Offline command for a specific item to the selected device. <ol style="list-style-type: none"> <li>1. Click the <b>RossTalk Device</b> button and select the device you want to send the RossTalk command to.</li> <li>2. Enter the take item id of the item you want to perform the action on in the <b>Take ID</b> field.</li> </ol>
RossTalk — Up Next	Devices > RossTalk (XPression) > Up Next	Send the Next command for a specific item to the selected device. <ol style="list-style-type: none"> <li>1. Click the <b>RossTalk Device</b> button and select the device you want to send the RossTalk command to.</li> <li>2. Enter the take item id of the item you want to perform the action on in the <b>Take ID</b> field.</li> </ol>

**Table 17: RossTalk (Generic)**

Event	Location	Description
RossTalk CC	Devices > RossTalk (Generic) > CC	Send the simulated custom control to the selected device. <ol style="list-style-type: none"> <li>1. Click the <b>RossTalk Device</b> button and select the device you want to send the RossTalk command to.</li> <li>2. Enter the bank of the custom control in the <b>Bank</b> field.</li> <li>3. Enter the number of the custom control in the <b>Custom</b> field.</li> </ol>
RossTalk Custom Command (CRLF)	Devices > RossTalk (Generic) > RossTalk Custom Cmd(CRLF)	Send a manual RossTalk string to the selected device. Each string has CRLF (carriage return line feed) appended to the end. <ol style="list-style-type: none"> <li>1. Click the <b>RossTalk Device</b> button and select the device you want to send the RossTalk command to.</li> <li>2. Enter the RossTalk string in the <b>Custom Cmd</b> field.</li> </ol>
RossTalk Custom Command (LF)	Devices > RossTalk (Generic) > RossTalk Custom Cmd(LF)	Send a manual RossTalk string to the selected device. Each string has LF (line feed) appended to the end. <ol style="list-style-type: none"> <li>1. Click the <b>RossTalk Device</b> button and select the device you want to send the RossTalk command to.</li> <li>2. Enter the RossTalk string in the <b>Custom Cmd</b> field.</li> </ol>
RossTalk Custom Command (CR)	Devices > RossTalk (Generic) > RossTalk Custom Cmd(CR)	Send a manual RossTalk string to the selected device. Each string has CR (carriage return) appended to the end. <ol style="list-style-type: none"> <li>1. Click the <b>RossTalk Device</b> button and select the device you want to send the RossTalk command to.</li> <li>2. Enter the RossTalk string in the <b>Custom Cmd</b> field.</li> </ol>
RossTalk Custom Command (no CRLF)	Devices > RossTalk (Generic) > RossTalk Custom Cmd(No CRLF)	Send a manual RossTalk string to the selected device. CRLF (carriage return line feed) is not appended to the end of the string. <ol style="list-style-type: none"> <li>1. Click the <b>RossTalk Device</b> button and select the device you want to send the RossTalk command to.</li> <li>2. Enter the RossTalk string in the <b>Custom Cmd</b> field.</li> </ol>
RossTalk — GPI	Devices > RossTalk (Generic) > GPI	Send the simulated GPI input to the selected device. <ol style="list-style-type: none"> <li>1. Click the <b>RossTalk Device</b> button and select the device you want to send the RossTalk command to.</li> <li>2. Enter the GPI you want to simulate triggering in the <b>GPI</b> field.</li> </ol>

**Table 18: RossTalk (Ultrix™)**

Event	Location	Description
RossTalk Custom Command	Devices > RossTalk (Ultrix) > RossTalk Custom Cmd	Send a manual RossTalk string to the selected device. <ol style="list-style-type: none"> <li>1. Click the <b>RossTalk Device</b> button and select the device you want to send the RossTalk command to.</li> <li>2. Enter the RossTalk string in the <b>Custom Cmd</b> field.</li> </ol>
RossTalk — MV Clock End	Devices > RossTalk (Ultrix) > MV Clock End	Send the end selected clock command to the selected device. <ol style="list-style-type: none"> <li>1. Click the <b>RossTalk Device</b> button and select the device you want to send the RossTalk command to.</li> <li>2. Enter the number of the clock you want to perform the action on in the <b>MV Clock</b> field.</li> </ol>
RossTalk — MV Clock Pause	Devices > RossTalk (Ultrix) > MV Clock Pause	Send the pause selected clock command to the selected device. <ol style="list-style-type: none"> <li>1. Click the <b>RossTalk Device</b> button and select the device you want to send the RossTalk command to.</li> <li>2. Enter the number of the clock you want to perform the action on in the <b>MV Clock</b> field.</li> </ol>
RossTalk — MV Clock Run	Devices > RossTalk (Ultrix) > MV Clock Run	Send the run selected clock command to the selected device. <ol style="list-style-type: none"> <li>1. Click the <b>RossTalk Device</b> button and select the device you want to send the RossTalk command to.</li> <li>2. Enter the number of the clock you want to perform the action on in the <b>MV Clock</b> field.</li> </ol>
RossTalk — MV Clock Stop	Devices > RossTalk (Ultrix) > MV Clock Stop	Send the stop selected clock command to the selected device. <ol style="list-style-type: none"> <li>1. Click the <b>RossTalk Device</b> button and select the device you want to send the RossTalk command to.</li> <li>2. Enter the number of the clock you want to perform the action on in the <b>MV Clock</b> field.</li> </ol>
RossTalk — Salvo	Devices > RossTalk (Ultrix) > Salvo	Send the fire salvo command to the selected device. <ol style="list-style-type: none"> <li>1. Click the <b>RossTalk Device</b> button and select the device you want to send the RossTalk command to.</li> <li>2. Enter the salvo you want to fire in the <b>SALVO</b> field.</li> </ol>

**Table 19: RossTalk (Tria)**

Event	Location	Description
RossTalk — Angle	Devices > RossTalk (Tria) > GoTo/Jog/Angle	Select the camera angle to use from the ISO clip loaded into the selected channel. <ol style="list-style-type: none"> <li>1. Click the <b>Action</b> button and click <b>Angle</b>.</li> <li>2. Click the <b>RossTalk Device</b> button and select the device you want to send the RossTalk command to.</li> <li>3. Click the <b>Channel</b> button and click the button for the channel that you want to perform the action on.</li> <li>4. Click the <b>Change Type</b> button and select whether you want to set (<b>Absolute</b>) or reset (<b>Reset</b>) the parameter. Some selections will not be available when you reset the parameter.</li> <li>5. In the <b>Value</b> field enter the camera angle you want to use from the clip loaded into the selected channel.</li> </ol>

Event	Location	Description
RossTalk — Cue Clip	Devices > RossTalk (Tria) > Play/Cue Clip	<p>Cue a specific clip on a selected channel. Clips are identified by file name.</p> <ol style="list-style-type: none"> <li>1. Click <b>Cue</b>.</li> <li>2. Click the <b>RossTalk Device</b> button and select the device you want to send the RossTalk command to.</li> <li>3. Click the <b>Channel</b> button and click the button for the channel that you want to perform the action on.</li> <li>4. In the <b>Clip</b> field enter the path and name of the clip to be cued. Clip names must include the path relative to the default H:\video\ directory.</li> </ol>
RossTalk — Cue Clip Position	Devices > RossTalk (Tria) > Play/Cue Clip From Position	<p>Cue a specific clip at a specific timecode on a selected channel. Clips are identified by file name.</p> <ol style="list-style-type: none"> <li>1. Click the <b>Action</b> button and click <b>Cue</b>.</li> <li>2. Click the <b>RossTalk Device</b> button and select the device you want to send the RossTalk command to.</li> <li>3. Click the <b>Channel</b> button and click the button for the channel that you want to perform the action on.</li> <li>4. In the <b>Clip</b> field enter the path and name of the clip to be cued. Clip names must include the path relative to the default H:\video\ directory.</li> <li>5. In the <b>Hours, Minutes, Seconds, and Frames</b> fields, enter the timecode you want to cue the clip at.</li> </ol>
RossTalk — Eject	Devices > RossTalk (Tria) > Play/Stop/Eject	<p>Unload the clip currently loaded into the selected channel.</p> <ol style="list-style-type: none"> <li>1. Click <b>Eject</b>.</li> <li>2. Click the <b>RossTalk Device</b> button and select the device you want to send the RossTalk command to.</li> <li>3. Click the <b>Channel</b> button and click the button for the channel that you want to perform the action on.</li> </ol>
RossTalk — Goto	Devices > RossTalk (Tria) > GoTo/Jog/Angle	<p>Send the Goto Position command to jog to a specific position in the clip loaded into the selected channel.</p> <ol style="list-style-type: none"> <li>1. Click the <b>Action</b> button and click <b>GoTo</b>.</li> <li>2. Click the <b>RossTalk Device</b> button and select the device you want to send the RossTalk command to.</li> <li>3. Click the <b>Channel</b> button and click the button for the channel that you want to perform the action on.</li> <li>4. Click the <b>Change Type</b> button and select whether you want to set (<b>Absolute</b>) or reset (<b>Reset</b>) the parameter. Some selections will not be available when you reset the parameter.</li> <li>5. In the <b>Value</b> field, enter the timecode (hh:mm:ss:ff) you want to seek to in the clip loaded into the selected channel.</li> </ol>
RossTalk — Jog	Devices > RossTalk (Tria) > GoTo/Jog/Angle	<p>Send the command to jog backward or forwards in the clip loaded into channel.</p> <ol style="list-style-type: none"> <li>1. Click the <b>Action</b> button and click <b>Jog</b>.</li> <li>2. Click the <b>RossTalk Device</b> button and select the device you want to send the RossTalk command to.</li> <li>3. Click the <b>Channel</b> button and click the button for the channel that you want to perform the action on.</li> <li>4. Click the <b>Change Type</b> button and select whether you want to set (<b>Absolute</b>) or reset (<b>Reset</b>) the parameter. Some selections will not be available when you reset the parameter.</li> <li>5. In the <b>Value</b> field, enter the direction +/- and amount, in frames, you want to jog in the clip loaded into the selected channel.</li> </ol>

Event	Location	Description
RossTalk — Loop Mode	Devices > RossTalk (Tria) > Loop Mode	Set the looping mode for the selected channel transport. <ol style="list-style-type: none"> <li>1. Click the <b>RossTalk Device</b> button and select the device you want to send the RossTalk command to.</li> <li>2. Click the <b>Channel</b> button and click the button for the channel that you want to perform the action on.</li> <li>3. Click the <b>Value</b> button as select the looping mode you want to set the selected channel to. The possible modes are <b>Off</b>, <b>Loop</b>, <b>Loop To</b>, <b>Ping Pong</b>, and <b>Ping Pong To</b>.</li> </ol>
RossTalk — Play Clip	Devices > RossTalk (Tria) > Play/Cue Clip	Play a specific clip on a selected channel. Clips are identified by file name. <ol style="list-style-type: none"> <li>1. Click <b>Play</b>.</li> <li>2. Click the <b>RossTalk Device</b> button and select the device you want to send the RossTalk command to.</li> <li>3. Click the <b>Channel</b> button and click the button for the channel that you want to perform the action on.</li> <li>4. In the <b>Clip</b> field enter the path and name of the clip to be played. Clip names must include the path relative to the default <b>H:\video\</b> directory.</li> </ol>
RossTalk — Play Clip Position	Devices > RossTalk (Tria) > Play/Cue Clip From Position	Play a specific clip at a specific timecode on a selected channel. Clips are identified by file name. <ol style="list-style-type: none"> <li>1. Click the <b>Action</b> button and click <b>Play</b>.</li> <li>2. Click the <b>RossTalk Device</b> button and select the device you want to send the RossTalk command to.</li> <li>3. Click the <b>Channel</b> button and click the button for the channel that you want to perform the action on.</li> <li>4. In the <b>Clip</b> field enter the path and name of the clip to be cued. Clip names must include the path relative to the default <b>H:\video\</b> directory.</li> <li>5. In the <b>Hours</b>, <b>Minutes</b>, <b>Seconds</b>, and <b>Frames</b> fields, enter the timecode you want to play the clip at.</li> </ol>
RossTalk — Stop	Devices > RossTalk (Tria) > Play/Stop/Eject	Send the Stop command for a specific channel to the selected device. <ol style="list-style-type: none"> <li>1. Click <b>Stop</b>.</li> <li>2. Click the <b>RossTalk Device</b> button and select the device you want to send the RossTalk command to.</li> <li>3. Click the <b>Channel</b> button and click the button for the channel that you want to perform the action on.</li> </ol>

## Video Server

Event	Location	Description
Video Server — Cue	Video Server > Cue	Send the Cue command and name of clip to cue to the selected device. <ol style="list-style-type: none"> <li>1. Click the <b>Video Server</b> button and select the device you want to send the command to.</li> <li>2. Click a <b>Channel</b> button to select the channel you want to send the command to.</li> <li>3. Enter the identifier of the clip in the <b>Cue</b> field.</li> </ol>
Video Server — Get Clips	Video Server > Get Clips	Query the selected device for a list of clips. <ol style="list-style-type: none"> <li>1. Click the <b>Video Server</b> button and select the device you want to send the command to.</li> <li>2. Click a <b>Channel</b> button to select the channel you want to send the command to.</li> </ol>

Event	Location	Description
<b>Video Server — Jog</b>	Video Server > <b>Jog</b>	<p>Send the jog command to the selected device. The Jog command is not supported by the internal Clip Player at this time.</p> <ol style="list-style-type: none"> <li>1. Click the <b>Video Server</b> button and select the device you want to send the command to.</li> <li>2. Click a <b>Channel</b> button to select the channel you want to send the command to.</li> <li>3. Click the <b>Change Type</b> button and select whether you want to set (<b>Absolute</b>) or reset (<b>Reset</b>) the parameter. Some selections will not be available when you reset the parameter.</li> <li>4. Enter the amount you want to jog in the <b>Jog</b> field.</li> </ol>
<b>Video Server — Loop Off</b>	Video Server > <b>Loop Off</b>	<p>Send the Loop Off command to the selected device.</p> <ol style="list-style-type: none"> <li>1. Click the <b>Video Server</b> button and select the device you want to send the command to.</li> <li>2. Click a <b>Channel</b> button to select the channel you want to send the command to.</li> </ol>
<b>Video Server — Loop On</b>	Video Server > <b>Loop On</b>	<p>Send the Loop On command to the selected device.</p> <ol style="list-style-type: none"> <li>1. Click the <b>Video Server</b> button and select the device you want to send the command to.</li> <li>2. Click a <b>Channel</b> button to select the channel you want to send the command to.</li> </ol>
<b>Video Server — Play</b>	Video Server > <b>Play</b>	<p>Send the Play command to the selected device.</p> <ol style="list-style-type: none"> <li>1. Click the <b>Video Server</b> button and select the device you want to send the command to.</li> <li>2. Click a <b>Channel</b> button to select the channel you want to send the command to.</li> </ol>
<b>Video Server — Record</b>	Video Server > <b>Record</b>	<p>Send the eject command to the device, followed by the record command. The clip is given the name <code>recording_DATE_TIME</code>.</p> <ol style="list-style-type: none"> <li>1. Click the <b>Video Server</b> button and select the device you want to send the command to.</li> <li>2. Click a <b>Channel</b> button to select the channel you want to send the command to.</li> <li>3. Enter a name for the clip in the <b>Record</b> field.</li> </ol>
<b>Video Server — Shuttle</b>	Video Server > <b>Shuttle</b>	<p>Send the shuttle command to the selected device. The Shuttle command is not supported by the internal Clip Player at this time.</p> <ol style="list-style-type: none"> <li>1. Click the <b>Video Server</b> button and select the device you want to send the command to.</li> <li>2. Click a <b>Channel</b> button to select the channel you want to send the command to.</li> <li>3. Click the <b>Change Type</b> button and select whether you want to set (<b>Absolute</b>) or reset (<b>Reset</b>) the parameter. Some selections will not be available when you reset the parameter.</li> <li>4. Enter the speed you want to shuttle in the <b>Shuttle</b> field.</li> </ol>
<b>Video Server — Stop</b>	Video Server > <b>Stop</b>	<p>Send the Stop command to the selected device.</p> <ol style="list-style-type: none"> <li>1. Click the <b>Video Server</b> button and select the device you want to send the command to.</li> <li>2. Click a <b>Channel</b> button to select the channel you want to send the command to.</li> </ol>

## MIDI Device OID List

The OID for the MIDI device is made of a number of parts separated by a period. These parts identify things like the device class (audiomixer), audio source, audio destination, and control function.

For example, the OID `audiomixer.aux.2.sdi2.volume` translates to device class (audiomixer), audio destination (aux.2), audio source (sdi2), and control function (volume). This is a continuous input that allows you to control the volume of SDI 2 on the Aux 2 out.

**Table 20: Audio Mixer OIDs**

Target	Syntax	Description
<b>Volume</b>		
Assignable Audio Channels	<code>audiomixer.main.audio1.volume</code>	Volume for assignable audio channel 1 input on the Main layer. Replace <code>audio1</code> with the assignable audio channel you want to set the volume for. Replace <code>main</code> with the Aux layer you want set the volume for ( <code>aux.1-aux.12</code> ).
Output Mix	<code>audiomixer.output.main.volume</code>	Primary volume for the Main layer. Replace <code>main</code> with the Aux layer you want set the volume for ( <code>aux.1-aux.12</code> ) or the Monitor output ( <code>monitor</code> ).
<b>Balance/Pan</b>		
Assignable Audio Channel	<code>audiomixer.main.audio1.pan</code>	Balance for assignable audio channel 1 input on the Main layer. Replace <code>audio1</code> with the assignable audio channel you want to set the balance for. Replace <code>main</code> with the Aux layer you want set the balance for ( <code>aux.1-aux.12</code> ).
<b>Equalization (EQ)</b>		
EQ Channel Select	<code>audiomixer.eqchannelselect</code>	Select the audio channel that you want to set the EQ for. This oid is assigned to a button on the same strip as that audio channel you want to EQ. This tells the mixer that the EQ values are to be applied to the selected audio channel.
EQ Bypass	<code>audiomixer.eqbypasscommon</code>	Bypass the equalization for the selected audio channel.
Low Shelf Gain	<code>audiomixer.lowshelfgaincommon</code>	Gain setting for the Low Shelf EQ of the selected audio channel.
Midrange 1 Gain	<code>audiomixer.midrange1gaincommon</code>	Gain setting for the Midrange 1 EQ of the selected audio channel.
Midrange 2 Gain	<code>audiomixer.midrange2gaincommon</code>	Gain setting for the Midrange 2 EQ of the selected audio channel.
High Shelf Gain	<code>audiomixer.highshelfgaincommon</code>	Gain setting for the High Shelf EQ of the selected audio channel.
Low Shelf Max Frequency (linear)	<code>audiomixer.lowshelfmaxfreqcommon</code>	Maximum Frequency setting for the Low Shelf EQ of the selected audio channel. Frequency selection is performed on a linear scale.
Midrange 1 Center Frequency (linear)	<code>audiomixer.midrange1centerfreqcommon</code>	Center Frequency setting for the Midrange 1 EQ of the selected audio channel. Frequency selection is performed on a linear scale.

Target	Syntax	Description
Midrange 2 Center Frequency (linear)	audiomixer .midrange2centerfreqcommon	Center Frequency setting for the Midrange 2 EQ of the selected audio channel. Frequency selection is performed on a linear scale.
Midrange 1 Q (linear)	audiomixer.midrange1qcommon	Q Ratio setting for the Midrange 1 EQ of the selected audio channel. Ratio selection is performed on a linear scale.
Midrange 2 Q (linear)	audiomixer.midrange2qcommon	Q Ratio setting for the Midrange 2 EQ of the selected audio channel. Ratio selection is performed on a linear scale.
High Shelf Minimum Frequency (linear)	audiomixer.highshelfminfreqcommon	Minimum Frequency setting for the High Shelf EQ of the selected audio channel. Frequency selection is performed on a linear scale.
Low Shelf Max Frequency (scaled)	audiomixer .lowshelfmaxfreqscaledcommon	Maximum Frequency setting for the Low Shelf EQ of the selected audio channel. Frequency selection is performed on a non-linear scale.
Midrange 1 Center Frequency (scaled)	audiomixer .midrange1centerfreqscaledcommon	Center Frequency setting for the Midrange 1 EQ of the selected audio channel. Frequency selection is performed on a non-linear scale.
Midrange 2 Center Frequency (scaled)	audiomixer .midrange2centerfreqscaledcommon	Center Frequency setting for the Midrange 2 EQ of the selected audio channel. Frequency selection is performed on a non-linear scale.
Midrange 1 Q (scaled)	audiomixer.midrange1qscaledcommon	Q Ratio setting for the Midrange 1 EQ of the selected audio channel. Ratio selection is performed on a non-linear scale.
Midrange 2 Q (scaled)	audiomixer.midrange2qscaledcommon	Q Ratio setting for the Midrange 2 EQ of the selected audio channel. Ratio selection is performed on a non-linear scale.
High Shelf Minimum Frequency (scaled)	audiomixer .highshelfminfreqscaledcommon	Minimum Frequency setting for the High Shelf EQ of the selected audio channel. Frequency selection is performed on a non-linear scale.
<b>Compressor / Limiter (C/L)</b>		
C/L Channel Select	audiomixer.clchannelselect	Select the audio channel that you want to set the C/L for. This oid is assigned to a button on the same strip as that audio channel you want to C/L. This tells the mixer that the C/L values are to be applied to the selected audio channel.
C/L Threshold	audiomixer.thresholdscaledcommon	The level at which the compressor starts to be applied.
C/L Attack	audiomixer .attackcontrolscaledcommon	The amount of time you want to pass between the level surpassing the threshold and the full compression ratio being applied
C/L Compression	audiomixer.compressionscaledcommon	The ratio for the amount of compression you want to apply.
C/L Release	audiomixer .releasecontrolscaledcommon	The amount of time you want to pass between the level falling below the threshold and the compression ratio returning to 1:1 (no compression applied).
C/L Makeup	audiomixer.makeupgainscaledcommon	Increase the gain of the audio after compression.
C/L Bypass	audiomixer.clbypasscommon	Bypass the equalization for the selected audio channel.

Target	Syntax	Description
<b>Gain</b>		
Analog	<code>audiomixer.ABM.1.1.gain</code>	Gain for the Analog 1 input. Replace <code>ABM.1.1</code> with the analog port on the ABM you want to set the gain for ( <code>ABM.1.1-ABM.3.8</code> ). For example, <code>ABM.2.5</code> is the Analog 5 input port on ABM 2.
<b>Pad</b>		
Analog	<code>audiomixer.ABM.1.1.pad</code>	Toggle pad for analog 1 input on ABM 1. Replace <code>ABM.1.1</code> with the analog port on the ABM you want to set pad for ( <code>ABM.1.1-ABM.3.8</code> ). For example, <code>ABM.2.5</code> is the Analog 5 input port on ABM 2.
<b>Phantom Power</b>		
Analog	<code>audiomixer.ABM.1.1.phantompower</code>	Toggle phantom power for the analog 1 input port on ABM a. Replace <code>ABM.1.1</code> with the analog port on the ABM you want to set phantom power for ( <code>ABM.1.1-ABM.3.8</code> ). For example, <code>ABM.2.5</code> is the Analog 5 input port on ABM 2.
<b>Mute</b>		
Assignable Audio Channel	<code>audiomixer.main.audio1.mute</code>	Toggle mute for assignable audio channel 1 input on the Main layer. Replace <code>audio1</code> with the assignable audio channel want to set mute for. Replace <code>main</code> with the Aux layer you want set mute for ( <code>aux.1-aux.12</code> ).
<b>Solo</b>		
Assignable Audio Channel	<code>audiomixer.main.audio1.solo</code>	Toggle solo for assignable audio channel 1 input on the Main layer. Replace <code>audio1</code> with the assignable audio channel input you want to set solo for. Replace <code>main</code> with the Aux layer you want set solo for ( <code>aux.1-aux.12</code> ).
<b>Clear Solo</b>		
Main	<code>audiomixer.output.main.clearsolo</code>	Clear solo for all sources on Main layer.
Monitor	<code>audiomixer.output.monitor.clearsolo</code>	Clear solo for all sources on Monitor layer.
Aux	<code>audiomixer.output.aux.1.clearsolo</code>	Clear solo for all sources on the Aux layers. Replace <code>Aux.1</code> with the Aux layer you want set solo for ( <code>aux.1-aux.12</code> ).
<b>Pre/Post</b>		
Assignable Audio Channel	<code>audiomixer.aux.1.audio1.pre</code>	Toggle pre fader for assignable audio channel 1 input on the Aux 1 layer. Replace <code>audio1</code> with the assignable audio channel input you want to set pre for. Replace <code>aux.1</code> with the Aux layer you want set pre for ( <code>aux.1-aux.12</code> ).
<b>PFL</b>		
Assignable Audio Channel	<code>audiomixer.audio1.pfl</code>	Toggle PFL for assignable audio channel 1. Replace <code>audio1</code> with the assignable audio channel input you want to set solo for ( <code>sdi1-sdi12</code> ).
<b>Clear PFL</b>		
All	<code>audiomixer.clearpfl</code>	Clear PFL on all sources.



---

# Glossary

## Interlaced

An Interlaced video format starts at the top of the screen and draws all the odd number scan lines and then all the even number scan lines in sequence. This results in half the image being drawn in one pass and the other half of the image being drawn in the second. These two passes are called Fields, where the first pass is called Field 1 and the second pass is called Field 2. When both Field 1 and Field 2 have been drawn, resulting in a complete image, you have a single Frame.

## Progressive

A Progressive scan video format draws each scan line in sequence, starting from the top of the screen and working to the bottom. Unlike Interlaced, with Progressive scan the entire image is drawn at one time, in a single pass. This means that there are no fields in a Progressive scan image.

## Auto Key

A pairing of two video signals, a key video and a key alpha, to create a key. In the switcher, you associate the fill and alpha so that the switcher knows which alpha to use when the video is selected.

## Auto Transition

An automatic transition in which the manual movement of the fader handle is simulated electronically. The transition starts when the **AUTO TRANS** button is pressed and takes place over a pre-selected time period, measured in frames.

## Chroma Key

Chroma Key is a key in which the hole is cut based on a color value, or hue, rather than a luminance value or alpha signal. The color is removed and replaced with background video from another source.

## Cut

An instantaneous switch from one video signal to another.

## Dissolve

A transition from one video signal to another in which one signal is faded down, while the other is simultaneously faded up. The terms mix or cross-fade are often used interchangeably with dissolve.

## Field

One half of a complete picture (or frame) interval containing all of the odd, or all of the even, lines in interlaced scanning. One scan of a TV screen is called a field; two fields are required to make a complete picture (which is a frame).

## Force, Mask

An effect that forces the masked region to the foreground but is not bound by the key. For example, if you have a key and apply a mask to it. The masked area is bound by the edges of the key. When force is turned on, the masked area is filled with the video from the key (nothing appears masked) but you can move the mask outside of the key and the key video is still filling the masked region.

## Frame

One complete picture consisting of two fields of interlaced scanning lines.

## File Transfer Protocol

A network protocol that is used to transfer files from one host computer to another over a TCP-based network.

## Gain

Gain represents the range of signal values present in a video signal from a lowest to a highest point (from black to white for example). Increasing gain expands this range, while decreasing gain compresses this range. Clipping occurs if applied gain changes cause output signal values to fall outside the allowable range. Generally, increasing the gain for a specific color component causes the video signal colors to become increasingly saturated with that color. Similarly, decreasing the gain for a specific color component progressively removes that color component from the output video signal.

## Gamma

Gamma corrections introduce non-linear corrections to a video signal. A gamma

---

correction can be described as taking a point on the output versus input video signal line and pulling it perpendicularly away from the line. The result is a Bezier curve between the start, the new point, and the end point. Generally, increasing the gamma value adds more of the component to the video signal in the location of the gamma offset point. Decreasing the gamma value reduces the amount of the component in the video signal in the location of the gamma offset point. Moving the gamma offset point allows you to select which part of the input video signal receives the gamma correction. For example, if you increase the red gamma correction to the part of the video signal that has no red component you will add red to those areas while having little effect on areas that already contain a significant amount of red. This allows you to add a red tint to the image while minimizing the amount of red-clipping that occurs.

### General Purpose Interface

A simple high/low signal that is used to trigger an action either on an external device or on the switcher. A GPI can be an input or an output to the switcher.

### High Definition

A high definition (720p, 1080i, or 1080p/3G) video signal.

### Hue

The characteristic of a color signal that determines whether the color is red, yellow, green, blue, purple, etc. (the three characteristics of a TV color signal are chrominance, luminance, and hue). White, black, and gray are not considered hues.

### Hue Rotation

Hue rotate affects the color of the entire video signal by rotating the input video hues. This produces an output video signal with colors that are shifted from their original hues. By rotating colors around the wheel, hue values will shift. For example, a clockwise rotation where yellows become orange, reds become magenta, blues become green. The more rotation applied, the further around the wheel colors are shifted.

### Key

An effect produced by cutting a hole in the background video, then filling the hole with video or matte from another source. Key source video cuts the hole, key fill video fills the hole. The video signal used for cut and fill can come from the same, or separate, sources.

### Key Alpha

The video signal which cuts a hole in the background video to make a key effect possible. Also called Key Video or Source. In practice, this signal controls when a video mixer circuit will switch from background to key fill video.

### Key Invert

An effect that reverses the polarity of the key source so that the holes in the background are cut by dark areas of the key source instead of bright areas.

### Key Mask

A keying technique in which a shape is combined with the key source to block out unwanted portions of the key source.

### Key Video

A video input which is timed to fill the hole provided by the key source video. An example of key video is the video output of a character generator.

### Linear Key

Linear keys make it possible to fully specify the transparency of a key from opaque, through transparent, to fully off. The transparency is specified by the key alpha that is associated with the key video. A keyer capable of a linear key converts the key signal voltage directly to the transparency effect on the screen.

### Mnemonics

A green, orange, or yellow display used to show the names of a source above or below the source button or used as a custom command or pattern button.

### Offsets

Offsets shift the video signal by a set amount. Depending on the offset applied, different parts or all of the video signal may be affected. Clipping occurs if applied offsets cause output signal values to fall outside the allowable range.

---

## Pre-Delay

A pre-delay is a delay that is inserted into a transition between the triggering of a GPI output and performing the transition. The length of the pre-delay is usually the length of time your video server requires to start playing a clip or your character generator required to load a page.

## Rosstalk

An ethernet based protocol that allows the control over Ross devices using plain english commands.

## Standard-Definition

A standard definition (480i or 576i) video signal.

## Self Key

A key effect in which the same video signal serves as both the key signal and key fill.

## Shaped Key

An additive key where the Key Alpha cuts a hole based on the monochrome value of the alpha. Shades of gray are translated into either white or black, giving the key a hard edge. Shaped Key alphas are sometimes used with Character Generators to cut very precise holes for the fill.

## Split Key

A Split key allows you to assign a different alpha source for a key than the fill/alpha associations that are set up during configuration or to use a separate alpha source for a Self key.

## Tally

An indicator which illuminates when the associated button, or control, is selected or is on-air.

## Unshaped Key

A multiplicative key where the Key Alpha cuts a hole based on the gradient values of the alpha. Shades of gray are translated into transparency levels, giving the key a soft edge. Unshaped Key alphas can also be considered true linear alphas.

---

# Index

## A

ABM [122](#)  
Access Control [20](#)  
AES Out [123](#)  
AES Output [123](#)  
AFV [54](#)  
AFV Set, Audio [53](#)  
Allocated DVEs [148](#)  
Ancillary Data [102](#)  
Ancillary Mode [148](#)  
Animations [66](#)  
Aspect Ratio Conversion [119](#)  
    Full [119](#)  
    Letterbox [119](#)  
    Pillarbox [119](#)  
    Zoom [119](#)  
Audio [58–59](#), [66](#)  
Audio Auxes [55](#)  
Audio Breakout Module [122](#)  
Audio Delay [56](#)  
Audio Follow Video [53](#)  
Audio Memories, Disable [48](#)  
Audio Mixer [18](#), [53](#)  
    DashBoard [18](#)  
Audio Out [123](#)  
AudioDucking [58](#)  
AudioTalkback [59](#)  
Auto Follow [97](#)  
    Custom Pages [97](#)  
Auto Key [96](#)  
Auto Select Keys [36](#)  
Aux Bus [25](#)  
    Source Selection [25](#)

## B

Balance, Audio [53](#)  
BG Source [28](#)  
Border Lighting [45](#)  
Bus Hold [48](#)  
Bus Map, Default [151](#)  
Bus Maps [130](#)  
Bus Select Buttons, ViewControl [138](#)  
Buses [23](#)  
    Ultritouch [23](#)  
Bypass CL [61](#)  
Bypass EQ [60](#)  
Bypass Noise Gate [58](#)

## C

Cache Manager [67](#)  
Canvas [25](#)  
    Source Selection [25](#)  
Capture [69](#)

CC, *See* Custom Controls  
CC Events, *See*  
CC Pause [74](#)  
Chroma Key [37](#)  
Clean Feed [26](#), [102–103](#)  
    Layer Mode [103](#)  
Clear Custom Controls [151](#)  
Clear Memories [151](#)  
Clip Names [71](#)  
Clip Player [71–72](#)  
    Audio [71](#)  
    File Names [71](#)  
    Supported Formats [71](#)  
Clock, MultiViewer [108](#)  
Color Background [28](#)  
Color Correction [124–125](#)  
    Proc Amp [124](#)  
    RGB [125](#)  
Color Schemes [130](#)  
Color Temperature [125](#)  
Colors, Memory Recall [49](#)  
Compressor [61](#)  
    Bypass [61](#)  
Copy Keys [29](#)  
Copy Logs [149](#)  
Copy MEs [29](#)  
CPU Temperature [148](#)  
Custom Control Buttons, ViewControl [138](#)  
Custom Control Event [160](#), [193](#)  
    ABM Input Delay [209](#)  
    AES Output [187](#)  
    Ancillary Data Mode [187](#)  
    Audio Pan [211](#)  
    Audio Volume [212](#)  
    Auto Trans [179](#)  
    BKGD DVE Aspect [160](#)  
    BKGD DVE Border Size [160](#)  
    BKGD DVE Crop [161](#)  
    BKGD DVE Edge Softness [161](#)  
    BKGD DVE Size [160](#)  
    BKGD DVE X-Position [160](#)  
    BKGD DVE Y-Position [160](#)  
    Box Mask Edge Position [168](#)  
    Box Mask Edge Softness [168](#)  
    Bus Source [177](#)  
    Cancel All CC [161](#)  
    Cancel CC [161](#)  
    Channel AFV Fade [210](#)  
    Channel Position [210](#)  
    Channel Processing Order [210](#)  
    Channel Visible [211](#)  
    Chroma Key Auto Adjust [162](#)  
    Chroma Key Color [162](#)  
    Chroma Key Initialize [162](#)  
    Chroma Key Measurement Source [163](#)  
    Chroma Key Parameters [163](#)  
    Chroma Key Re-Spill Color [163](#)

---

Custom Control Event (*continued*)

Chroma Key Re-Spill Saturation [163](#)  
CL Attack [205](#)  
CL Channel AFV Fade [206](#)  
CL Channel Position [206](#)  
CL Channel Processing Order [206](#)  
CL Channel Visible [206](#)  
CL CL Bypass [206](#)  
CL Clear PFL [206](#)  
CL Clear Solo [206](#)  
CL Compression [207](#)  
CL Default All CL [207](#)  
CL Default Selected CL [207](#)  
CL Makeup [207](#)  
CL Output Volume [207](#)  
CL Pad [207](#)  
CL Phantom Power [207](#)  
CL Pre-Amp Gain [208](#)  
CL Processing Order [208](#)  
CL Release [208](#)  
CL Source AFV Input [208](#)  
CL Source Audio Channel [208](#)  
CL Source Audio Input [208](#)  
CL Threshold Control [208](#)  
CL Video Out Audio Mix [209](#)  
CL Video Out Custom Audio Mix [209](#)  
Clean Feed [187](#)  
Clear PFL [209](#)  
Clear Solo [209](#)  
Color Corrector Color Reset [187](#)  
Color Corrector Enable [187](#)  
Color Corrector Gain [187](#)  
Color Corrector Gamma [187](#)  
Color Corrector Gamma Offset [188](#)  
Color Corrector Lower Offset [188](#)  
Color Corrector Offset [188](#)  
Color Corrector Reset [188](#)  
Color Gamut [188](#)  
Cut Transition [180](#)  
Delay Auto Trans [182](#)  
Disable Audio Memories [188](#)  
Ducking Attack [201](#)  
Ducking Default All [201](#)  
Ducking Default Channel [201](#)  
Ducking Depth [201](#)  
Ducking Hold [202](#)  
Ducking Mix Reduction [202](#)  
Ducking Mode [202](#)  
Ducking Release [202](#)  
Ducking Threshold [202](#)  
DVE Freeze [163](#)  
DVE Key Aspect [163](#)  
DVE Key Border [164](#)  
DVE Key Border Color (HSL) [164](#)  
DVE Key Border Color (Preset) [164](#)  
DVE Key Crop (Bottom Edge) [164](#)  
DVE Key Crop (Dual Edge) [164](#)  
DVE Key Crop (Left Edge) [165](#)  
DVE Key Crop (Right Edge) [165](#)  
DVE Key Crop (Top Edge) [165](#)  
DVE Key Edge Softness [165](#)

Custom Control Event (*continued*)

DVE Key Size [165](#)  
DVE Key X-Position [166](#)  
DVE Key Y-Position [166](#)  
DVE Wipe Direction [180](#)  
DVE Wipe Direction (Flip-Flop) [180](#)  
DVE Wipe Pattern [180](#)  
DVE Wipe, Reset [180](#)  
Dynamic Range [189](#)  
EQ Default All EQ [203](#)  
EQ Default Selected EQ [204](#)  
EQ EQ Bypass [204](#)  
EQ High Shelf Gain [204](#)  
EQ High Shelf Min Freq [204](#)  
EQ Low Shelf Gain [204](#)  
EQ Midrange 1 Center Freq [204](#)  
EQ Midrange 1 Gain [204](#)  
EQ Midrange 1 Q [205](#)  
EQ Midrange 2 Center Freq [205](#)  
EQ Midrange 2 Gain [205](#)  
EQ Midrange 2 Q [205](#)  
Field Dominance [192](#)  
*See also* Switching Field  
Fly Key (DVE) [166](#)  
FSFC Input Assignment [189](#)  
GPI Output — Edge Trigger Setup [213](#)  
GPI Output — Level Trigger Setup [213](#)  
GPI Output — Mode [213](#)  
GPI Output — Trigger [213](#)  
GPI Output — Trigger Type [213](#)  
Hold CC [161](#)  
Input Color Gamut [188](#)  
Input Dynamic Range [189](#)  
Input Frame Delay [189](#)  
Input FSFC Assignment [189](#)  
Input FSFC Framing [189](#)  
Input Scaler Mode [189](#)  
Key Active [166](#)  
Key Copy [166](#)  
Key Invert [167](#)  
Key Mode [167](#)  
Key Only Transition [162](#)  
Key Settings (Clip, Gain, Transparency) [167](#)  
Key Trans Rate [162](#)  
Key Type [167](#)  
Key, Make Linear [166](#)  
Key, Reset [167](#)  
Layer Mode [189](#)  
Loop CC [161](#)  
Mask [171](#)  
Mask (Box) — Left Edge Position [168](#)  
Mask (Box) — Right Edge Position [168](#)  
Mask (Box) — Size [168](#)  
Mask (Box) — Top Edge Position [169](#)  
Mask (Box) — X-Position [169](#)  
Mask (Box) — Y-Position [169](#)  
Mask (Pattern) — Aspect Ratio [169](#)  
Mask (Pattern) — Border Size [169](#)  
Mask (Pattern) — Edge Softness [169](#)  
Mask (Pattern) — Horizontal Multiplication [170](#)  
Mask (Pattern) — Reset [170](#)

---

Custom Control Event (*continued*)

Mask (Pattern) — Rotation [170](#)  
Mask (Pattern) — Size [170](#)  
Mask (Pattern) — Vertical Multiplication [170](#)  
Mask (Pattern) — X-Position [170](#)  
Mask (Pattern) — Y-Position [170](#)  
Mask, Force [167](#)  
Mask, Invert [168](#)  
Matte Color (HSL) [175](#)  
Matte Color (Preset) [175](#)  
Matte Color, Reset [175](#)  
ME Copy [177](#)  
ME Dissolve Type [181](#)  
ME Follow [189](#)  
ME Trans Rate [181](#)  
ME Trans Type [181](#)  
ME WhiteFlash Color [181](#)  
ME WhiteFlash Offset [182](#)  
ME WhiteFlash Onset [182](#)  
Media Cut Point, Set [180](#)  
Media Trans End Point, Set [181](#)  
Media Trans Start Point, Set [181](#)  
Media Trans Thumbnail [181](#)  
Media-Store — Auto Play [171](#)  
Media-Store — Capture [171](#)  
Media-Store — Capture Alpha [171](#)  
Media-Store — Capture Alpha Source [171](#)  
Media-Store — Capture Mode [171](#)  
Media-Store — Capture Source [171](#)  
Media-Store — Clear Channel [172](#)  
Media-Store — Cut Frame [172](#)  
Media-Store — Delete Capture [172](#)  
Media-Store — Load [172](#)  
Media-Store — Looping [172](#)  
Media-Store — Move To Frame [172](#)  
Media-Store — Mute [173](#)  
Media-Store — Play [173](#)  
Media-Store — Play Speed [173](#)  
Media-Store — Reset Media [173](#)  
Media-Store — Reverse [173](#)  
Media-Store — Rewind [173](#)  
Media-Store — Shaped [173](#)  
Media-Store — Thumb Frame [174](#)  
Media-Store — Trigger GPI Output Delay [174](#)  
Media-Store — Trigger GPI Output [174](#)  
Media-Store — X-Position [174](#)  
Media-Store — Y-Position [174](#)  
MediaWipe — Channel [180](#)  
MediaWipe — Direction [181](#)  
MediaWipe — Direction, Flip-Flop [180](#)  
MediaWipe — Layer [181](#)  
Memory Recall [177](#)  
MultiViewer — Clip [195](#)  
MultiViewer — Follow [197](#)  
MultiViewer — FSFC Label [197](#)  
MultiViewer — Layout [197](#)  
MultiViewer — Overlay [197](#)  
MultiViewer — Shift [198](#)  
MultiViewer — Shift Panel [198](#)  
MultiViewer — Tally Display [198](#)  
MultiViewer — ViewControl Shift [198](#)

Custom Control Event (*continued*)

MultiViewer Box — Apply to All [193](#)  
MultiViewer Box — Aspect Ratio Markers [193](#)  
MultiViewer Box — Border [193](#)  
MultiViewer Box — Green Tally (Preview) [193](#)  
MultiViewer Box — Label [193](#)  
MultiViewer Box — Label Mode [194](#)  
MultiViewer Box — Label Position [194](#)  
MultiViewer Box — Label Transparency [194](#)  
MultiViewer Box — Red Tally (On-Air) [194](#)  
MultiViewer Box — Video Source [194](#)  
MultiViewer Clock — Background Color (HSL) [195](#)  
MultiViewer Clock — Background Color (Preset) [195](#)  
MultiViewer Clock — Countdown Timer Direction [195](#)  
MultiViewer Clock — Countdown Timer Reset [195](#)  
MultiViewer Clock — Countdown Timer State [195](#)  
MultiViewer Clock — Foreground Color (HSL) [195](#)  
MultiViewer Clock — Foreground Color (Preset) [196](#)  
MultiViewer Clock — Format [196](#)  
MultiViewer Clock — Mode [196](#)  
MultiViewer Clock — MV Timer [196](#)  
MultiViewer Clock — Size [196](#)  
MultiViewer Clock — Timecode Frame Count [196](#)  
MultiViewer Clock — Timer Set Time (Minutes) [196](#)  
MultiViewer Clock — Timer Set Time (Seconds) [197](#)  
MultiViewer Clock — X-Position [197](#)  
MultiViewer Clock — Y-Position [197](#)  
NG Attack [200](#)  
NG Bypass [200](#)  
NG Default All [200](#)  
NG Default Channel [200](#)  
NG Depth [200](#)  
NG Hold [200](#)  
NG Release [201](#)  
NG Threshold [201](#)  
Output BNC Assignment [190](#)  
Output Color Gamut [188](#)  
Output Dynamic Range [189](#)  
Output FSFC Video Format [190](#)  
Output Rotation Mode [191](#)  
Output Rotation X-Position [191](#)  
Output Rotation Y-Position [192](#)  
Output Rotation Zoom [191](#)  
Output Volume [209](#)  
Pad [209](#)  
Pause CC [161](#)  
PBus — Recall [213](#)  
PBus — Trigger [214](#)  
Personality — Auto Remove Key [186](#)  
Personality — Auto Trans Second Press (Key) [186](#)  
Personality — Auto Trans Second Press (ME) [186](#)  
Personality — Next Trans Reset [186](#)  
Personality — Roll Clip [186](#)  
Phantom Power [210](#)  
Play CC [161](#)  
Pre-Amp Gain [210](#)  
Proc Amp Enable [190](#)  
Proc Amp Gain [190](#)  
Proc Amp Gamma [190](#)  
Proc Amp Gamma Offset [190](#)  
Proc Amp Hue Rotation [191](#)

---

Custom Control Event (*continued*)

Proc Amp Offset [191](#)  
Proc Amp Reset [191](#)  
Proc Amp/Color Corrector Reset [190](#)  
Processing Order [211](#)  
RAVE AFV [198](#)  
RAVE AFV Volume [198](#)  
RAVE Aux Pre/Post [199](#)  
RAVE Bal/Pan [199](#)  
RAVE Input Volume [199](#)  
RAVE Mute [199](#)  
RAVE PFL [199](#)  
RAVE Solo [200](#)  
Reference Source [191](#)  
Reset [182](#)  
Resume All CC [162](#)  
Resume CC [161](#)  
Robotic Camera — Halt All [212](#)  
Robotic Camera — Recall Shot [212](#)  
Robotic Camera — Recall Shot Fast [212](#)  
Robotic Camera — Store Shot [212](#)  
Roll Clip [182](#)  
RossTalk — Angle [218](#)  
RossTalk — CC [214](#), [217](#)  
RossTalk — Clear All [214](#)  
RossTalk — Clear Channel [214](#)  
RossTalk — Clear Layer [214](#)  
RossTalk — Cue Channel [214](#)  
RossTalk — Cue Clip [219–220](#)  
RossTalk — Cue Clip Position [219](#)  
RossTalk — Cue Current [214](#)  
RossTalk — Cue Item [215](#)  
RossTalk — Cue Layer [215](#)  
RossTalk — Eject [219](#)  
RossTalk — Focus [215](#)  
RossTalk — Goto [219](#)  
RossTalk — GPI [215](#), [217](#)  
RossTalk — Jog [219](#)  
RossTalk — Layer Off [215](#)  
RossTalk — Loop Mode [220](#)  
RossTalk — MV Clock End [218](#)  
RossTalk — MV Clock Pause [218](#)  
RossTalk — MV Clock Run [218](#)  
RossTalk — MV Clock Stop [218](#)  
RossTalk — Next [215](#)  
RossTalk — Play Clip Position [220](#)  
RossTalk — Read Current [215](#)  
RossTalk — Read Item [215](#)  
RossTalk — Read Layer [215](#)  
RossTalk — Resume Channel [216](#)  
RossTalk — Resume Layer [216](#)  
RossTalk — Salvo [218](#)  
RossTalk — Sequencer Down [216](#)  
RossTalk — Sequencer Up [216](#)  
RossTalk — Stop [220](#)  
RossTalk — Swap Channel [216](#)  
RossTalk — Swap Current [216](#)  
RossTalk — Swap Layer [216](#)  
RossTalk — Take Channel [216](#)  
RossTalk — Take Item [216](#)  
RossTalk — Take Layer [217](#)

Custom Control Event (*continued*)

RossTalk — Take Offline [217](#)  
RossTalk — Up Next [217](#)  
RossTalk Custom Command [215](#), [217–218](#)  
Row ME Assignment [176](#)  
RState, Load [177](#)  
Sequencer Clear [176](#)  
Sequencer Down [176](#)  
Sequencer Link [176](#)  
Sequencer Load [176](#)  
Sequencer Next [176](#)  
Sequencer Reload [176](#)  
Sequencer Up [176](#)  
Source AFV Input [211](#)  
Source Audio Channel [211](#)  
Source Audio Input [211](#)  
Source Bus Substitution [192](#)  
Source ME Substitution [192](#)  
Source Substitution, Delete [192](#)  
State, Insert [162](#)  
Talkback Attack [202](#)  
Talkback Default All [203](#)  
Talkback Default Channel [203](#)  
Talkback Hold [203](#)  
Talkback Mix Reduction [203](#)  
Talkback Mode [203](#)  
Talkback Release [203](#)  
Test Tone Frequency [211](#)  
Trans Clear [182](#)  
Trans Elements [182](#)  
Trans Limit — On/Off [182](#)  
Trans Limit — Reset [182](#)  
Trans Limit — Set [183](#)  
Trans Limit — Value [183](#)  
Transition Action Dissolve [178](#)  
Transition Action DVE [179](#)  
Transition Action MediaWipe [179](#)  
Transition Action Wipe [178](#)  
TSL Address [192](#)  
TSL Tally MultiViewer Display Mode [192](#)  
UltraScene Recall [185](#)  
UltraScene Store [185](#)  
Video Mode [192](#)  
Video Out Audio Mix [210](#)  
Video Out Custom Audio Mix [210](#)  
Video Server — Cue [220](#)  
Video Server — Get Clips [220](#)  
Video Server — Jog [221](#)  
Video Server — Loop Off [221](#)  
Video Server — Loop On [221](#)  
Video Server — Play [221](#)  
Video Server — Record [221](#)  
Video Server — Shuttle [221](#)  
Video Server — Stop [221](#)  
Wash Color (HSL) [175](#)  
Wash Color (Preset) [175](#)  
Wash Color Reset [175](#)  
Wash Generator — Disable [175](#)  
Wash Generator — Enable [175](#)  
Wipe Direction [183](#)  
Wipe Direction (Flip-Flop) [183](#)

## Custom Control Event (*continued*)

- Wipe Pattern — Aspect Ratio [183](#)
- Wipe Pattern — Border Color (HSL) [183](#)
- Wipe Pattern — Border Color (Preset) [184](#)
- Wipe Pattern — Border Size [184](#)
- Wipe Pattern — Edge Softness [184](#)
- Wipe Pattern — Horizontal Multiplication [184](#)
- Wipe Pattern — Pattern [184](#)
- Wipe Pattern — Rotation [184](#)
- Wipe Pattern — Size [184](#)
- Wipe Pattern — Vertical Multiplication [185](#)
- Wipe Pattern — X-Position [185](#)
- Wipe Pattern — Y-Position [185](#)
- Wipe Reset [185](#)

## Custom Controls [18](#), [23](#), [74–77](#), [160–162](#), [171](#), [175–178](#), [185–187](#), [193](#), [198](#), [211–214](#), [220](#)

- Audio Events [211](#)
- BKGD DVE Events [160](#)
- Camera Events [212](#)
- CC Events [161](#)
- CC Pause [74](#)
- Combined Transition Events [178](#)
- Copy/Paste [77](#)
- DashBoard [18](#)
- Deleting [77](#)
- Editing [74](#)
- GPI Events [213](#)
- Individual Transition Events [178](#)
- Installation Events [187](#)
- Keyer Events [162](#)
- Matte Events [175](#)
- Media Events [171](#)
- MultiViewer Events [193](#)
- Naming [76](#)
- Pause Mode [75](#)
- PBus Events [213](#)
- Personality Events [186](#)
- Rave Audio Events [198](#)
- Recording [74](#)
- RossTalk Events [214](#)
- Run Event [74](#)
- Running [75](#)
- Sequencer [78](#)
- Sequencer Events [176](#)
- Special Events [176](#)
- Switcher Events [177](#)
- UltraScene Events [185](#)
- Ultritouch [23](#)
- Video Server Events [220](#)

## Custom Controls, Default [151](#)

## Custom Pages [97–98](#)

- Auto Follow [97](#)

## Custom Reset [151](#)

## Cut Transitions [32](#)

## D

### DashBoard [17–18](#), [21](#)

- Audio Mixer [18](#)
- Configuration [17](#)
- Custom Controls [18](#)

## DashBoard (*continued*)

- Devices [17](#)
- Live Assist [17](#)
- MediaManager [18](#)
- Panel [21](#)
- PaneLINK [17](#)
- Personality [18](#)
- Status [17](#)
- ViewControl [18](#)
- DashBoard Connections [148](#)
- DashBoard Menus [17](#)
- DashBoard Reboot [17](#)
- Date, System Time [121](#)
- Default [151](#)
  - Factory [151](#)
- Default Bus Map [151](#)
- Delays [120](#)
- Delete Media Item [66](#)
- Delete Memory [51](#)
- Delete Still [68](#)
- Deleting a Still [66](#)
- Device Control [13](#)
- Diagnostics [149](#)
  - Copy Logs [149](#)
- DIP Switches [152](#)
- Disable Audio Memories [48](#)
- Disable FTP [86](#)
- Disable Web Media Manager [66](#)
- Dissolve Transitions [32](#)
- Drop Shadow [45](#)
- Ducking [58–59](#)
- DVE [42–43](#)
  - Cropping [43](#)
  - Key [42–43](#)
- DVE Freeze [43](#)
- DVE Transitions [33](#)

## E

- EDL [135](#)
- Eject Media Item [66](#)
- Engine Type [148](#)
- EQ, *See* Equalization
- EQ Bypass [60](#)
- Equalization [60](#)
  - Bypass [60](#)
  - High Shelf [60](#)
  - Low Shelf [60](#)
  - Midrange [60](#)
- Ethernet [85](#)
- Events, Custom Control [160](#)
- External Reference [148](#)

## F

- Factory Default [151](#)
- Fade to Black [133](#)
- Fader, Audio [53](#)
- Fan#1 OK [148](#)
- Fan#2 OK [148](#)



Fan#3 OK [148](#)  
Field Dominance [148](#)  
FlexiClean [26](#), [102](#)  
Fly Key [42](#)  
Follows, ME [103](#)  
Format Conversion [115](#)  
FPGA Temperature [148](#)  
Frame Delay [120](#)  
Frame Setup, Ethernet [85](#)  
Frame Synchronizer [115](#)  
Freeze [43](#)  
FSFC [115](#), [117](#), [119](#)  
    Input [117–118](#)  
    Output [118–119](#)  
    QuadFS [117](#)  
    SDI-FS [117](#)  
FTP [86](#)  
FTP Disable [86](#)

## G

Gain, Audio [56](#)  
Gate [57](#)  
Glow [130](#)  
GPI [96](#), [133](#)  
    Assign to Source [96](#)  
    Setup [133](#)  
GPO Tally [134](#)

## H

Help [18](#)  
High Shelf, EQ [60](#)

## I

Input FSFC [117–118](#)  
IO Processor [114](#)  
IP Address [148](#)

## K

Key Preview [36–38](#), [43](#)  
Key RATE [32](#)  
Key Swap [29](#)  
Keyer Transition Buttons, ViewControl [138](#)  
Keying [36–37](#), [42–43](#), [45–46](#)  
    Auto Select [36](#)  
    Chroma Key [37](#)  
    Cropping [43](#)  
    DVE [42–43](#)  
    Key Priority [36](#)  
    Mask [45](#)  
    Self Key [36](#)  
    Split [37](#)  
    Split Keys [46](#)  
Keys [29](#)  
    Copy [29](#)

## L

Layer Mode [103](#)  
Layers, Audio [53](#)  
Licenses [132](#)  
Lighting, Border [45](#)  
Limiter [61](#)  
Live Assist [17](#), [98](#)  
    Custom Pages [98](#)  
    PaneLINK [17](#)  
LiveEDL [135–136](#)  
    Capture [136](#)  
    Store [136](#)  
Low Shelf, EQ [60](#)

## M

Mask [45](#)  
Matte [28](#)  
ME [25](#)  
    Source Selection [25](#)  
ME Copying [29](#)  
ME Follows [98](#), [103](#)  
    Substitution Table [98](#)  
Media Transitions [34](#)  
Media-Manager [68](#)  
    Delete Media Item [68](#)  
Media-Store [66–69](#)  
    Animations [66](#)  
    Audio [66](#)  
    Cache Manager [67](#)  
    Capture [69](#)  
    Clear Channel [66](#)  
    Delete Database Entry [66](#)  
    Disable Web Media Manager [66](#)  
    Eject [66](#)  
    File Specifications [67](#)  
    Loading [68](#)  
MediaManager [18](#), [66](#)  
    DashBoard [18](#)  
    Disable [66](#)  
Memories [48–51](#)  
    As Stored Attribute [49](#)  
    Attributes [50](#)  
    Bus Hold [48](#)  
    Delete [51](#)  
    No Recall Attribute [49](#)  
    Recall Attribute [49](#)  
    Recall Colors [49](#)  
    Storing [48](#)  
Memories, Default [151](#)  
Memories, UltraScene [83](#)  
Memory Names [52](#)  
Menu Group Access [18](#)  
Midrange, EQ [60](#)  
MiniME [25](#), [30](#)  
    Source Selection [25](#)  
    Transitions [30](#)  
Mixer Layer Names [55](#)  
Mnemonic Source Names [94](#)

Mnemonics [52, 95](#)  
Memory [52](#)  
MultiPanel [23, 143](#)  
  Ultritouch [23](#)  
MultiScreen [98–99, 111, 113](#)  
  Substitution Table [98–99, 113](#)  
MultiViewer [27, 105, 108](#)  
  Clock [108](#)  
  Time-Clock [105](#)  
Mute, Audio [53](#)

## N

NDI [141](#)  
Network Connection [85](#)  
Network Ports [85, 157](#)  
Noise Gate [57–58](#)  
  Bypass [58](#)

## O

On-Air Setting [104](#)  
Orchestration [86](#)  
Output FSFC [118–119](#)  
Output Rotation [101](#)  
Output Synchronizer [91](#)  
Outputs [100–101](#)  
  Rotation [101](#)  
  Video [100](#)

## P

PAD, Audio [56](#)  
Pan, Audio [53](#)  
PanelBuilder [140](#)  
PaneLINK [17](#)  
Pause Mode, Custom Control [75](#)  
Permissions, Menu Group [18](#)  
Personality [18, 128](#)  
  DashBoard [18](#)  
PFL [53](#)  
Phantom Power, Audio [56](#)  
Ports, Network [157](#)  
Power Connected [148](#)  
Pre Fader Listen [53](#)  
Pre-Tiled Sources [98](#)  
Preamp [56](#)  
Preview [27](#)  
Proc Amp [124](#)

## Q

QuadFS [117](#)

## R

Rate, Transition [30](#)  
RBAC [20](#)  
Re-Entry [26](#)

Real-Time Clock, System [121](#)  
Reboot DashBoard [17](#)  
Reference [88, 90–91](#)  
  External [90](#)  
  Internal [90](#)  
  Output Sync [91](#)  
  Video Switching Field [91](#)  
Reference OK [148](#)  
Reference Source [148](#)  
Remove Media-Store Item [67](#)  
Reset [151](#)  
  Custom [151](#)  
RGB [125](#)  
RGB Color Correctors [125](#)  
Ross Platform Manager [86](#)  
RossLink [86](#)  
RossTalk Port [148](#)  
RPM [86](#)  
RState [151](#)  
RState, Save [151](#)

## S

Save Custom Reset [151](#)  
Scene Memories [83](#)  
Scenes [81](#)  
SDI-FS [117](#)  
SDR/HDR Conversion [15, 125](#)  
Self Key [36](#)  
Sequencer [78–80](#)  
  Copy/Paste [80](#)  
  Creating [78](#)  
  Deleting [80](#)  
  Editing [78](#)  
  Loading [79](#)  
  Naming [79](#)  
  Running [79](#)  
Serial Number [148](#)  
Sets [63](#)  
  Loading [63](#)  
  Storing [63](#)  
Shadow [45](#)  
Shifted Buses [130](#)  
Show Alpha [36–38, 43, 45](#)  
Simple Mixer Layer [55](#)  
SoftPanel [21–22](#)  
  Bus Area [22](#)  
  Control Area [21](#)  
  Menu Area [21](#)  
  User Area [21](#)  
Software Options [132](#)  
Software Version [148](#)  
Solo Clear, Audio [53](#)  
Solo, Audio [53](#)  
Source Names [94](#)  
Sources [26](#)  
  Layering [26](#)  
  Re-Entry [26](#)  
Specifications [158–159](#)  
  AES [159](#)  
  GPI I/O [158](#)

---

## Specifications (*continued*)

- LTC [159](#)
- Serial Port [158](#)
- Tally [158](#)
- Split Key [46](#)
- Split Keys [37](#)
- Status [23](#), [148](#)
  - Ultritouch [23](#)
- Storing Memories [48](#)
- Substitution Table [99](#), [113](#)
  - MultiScreen [99](#), [113](#)
- Substitution Tables [98](#)
- swInfo.txt [148](#)
- Switcher Information File [148](#)
- Switcher Mode [148](#)
- Switcher Status [148](#)
- Switching Field [91](#)
- System Real-Time Clock [121](#)

## T

- Talkback [59](#)
- Tallies [97](#), [134](#)
  - GPO [134](#)
- Temperature OK [148](#)
- Thumbnail, Clip Player [72](#)
- Time-Clock [105](#)
- Timecode [135](#), [148](#)
- Trans Limit [30](#)
- Transition Buttons, ViewControl [138](#)
- Transitions [30](#), [32–34](#)
  - Cuts [32](#)
  - Direction [30](#)
  - Dissolves [32](#)
  - DVE [33](#)
  - Flip Flop [30](#)
  - from Touchscreen Menu [30](#)
  - Media [34](#)
  - MiniME [30](#)
  - Pause [30](#)
  - Rate [30](#)
  - Roll Clip [30](#)
  - Trans Preview [30](#)
  - Whiteflash [32](#)
  - Wipes [33](#)
- Transitions Limit [30](#)
- TSL UMD [94](#)
- TSL UMD Port [148](#)

## U

- UltraScene [81](#)
  - Memories [83](#)
  - Scene [81](#)
- Ultritouch [23](#)
  - Buses [23](#)
  - Custom Controls [23](#)
  - MultiPanel [23](#)
  - Navigation Menu [23](#)
  - Status [23](#)
- User Buttons [131](#)

## V

- Video Inputs [93–94](#), [96](#)
  - Auto Key [96](#)
  - GPI Device Control [96](#)
  - Names [94](#)
- Video Layering [26](#)
- Video Mode [90](#), [148](#)
  - Setup [90](#)
- Video Output [102](#), [105](#)
  - Ancillary Data [102](#)
  - Clean Feed [102](#)
  - MultiViewer [105](#)
- Video Outputs [100](#)
- Video Processing and Flow [24](#)
- Video Source [25](#), [130](#)
  - Bus Map [130](#)
- Video Sources [25](#)
  - External [25](#)
  - Follows [25](#)
  - Internal [25](#)
  - Selecting [25](#)
  - Selecting on DashBoard [25](#)
- ViewControl [18](#), [138–139](#), [141](#)
  - Bus Selection Buttons [138](#)
  - Button Setup [139](#)
  - Custom Control Buttons [138](#)
  - Keyer Transition Buttons [138](#)
  - NDI [141](#)
  - Transition Buttons [138](#)

## W

- WCG Conversion [15](#), [125](#)
- Whiteflash [32](#)
- WhiteFlash [32](#)
- Wipe Transitions [33](#)